

# PROJECT GEMINI

SUPPLEMENT

## familiarization manual

SEDR 300

COPY NO.   /  

### **RENDEZVOUS and DOCKING CONFIGURATIONS**

THIS PUBLICATION SUPPLEMENTS  
SEDR 300 VOLUME II

**MCDONNELL**

THIS DOCUMENT SUPERSEDES  
DOCUMENT DATED 31 MAY 1965

*NOTICE: This material contains information affecting the national defense of the United States within the meaning of the Espionage Laws, Title 18, U.S.C., Sections 793 and 794, the transmission or revelation of which in any manner to an unauthorized person is prohibited by law.*

GROUP-4  
DOWNGRADED AT 3-YEAR INTERVALS;  
DECLASSIFIED AFTER 12 YEARS

CONFIDENTIAL

1 JULY 1966

# GUIDANCE and CONTROL SYSTEM

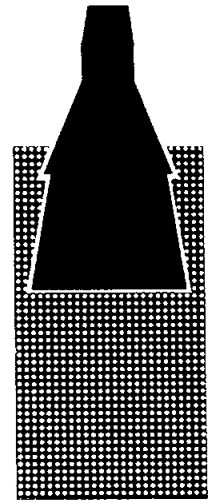

## Section VIII

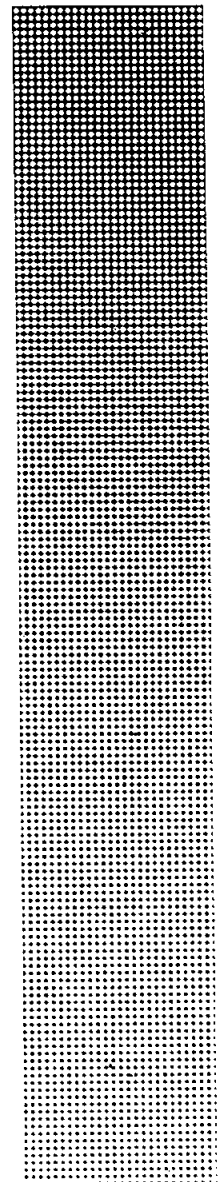

### TABLE OF CONTENTS

TITLE	PAGE
GENERAL.....	8-3
ATTITUDE CONTROL AND MANEUVER ELECTRONICS .....	8-15
INERTIAL GUIDANCE SYSTEM .....	8-43
HORIZON SENSOR SYSTEM .....	8-201
RENDEZVOUS RADAR SYSTEM .....	8-233
COMMAND LINK.....	8-273
RENDEZVOUS EVALUATION POD.....	8-289
TIME REFERENCE SYSTEM .....	8-301
PROPULSION SYSTEM .....	8-341



# PROJECT GEMINI



## GUIDANCE AND CONTROL - GENERAL

### GENERAL

The Guidance and Control System provides the Gemini Spacecraft with the capability to maneuver in space, control its attitude in relation to the earth's surface, and effect a safe re-entry. It also provides back-up launch vehicle guidance during ascent and control of certain target vehicle functions during rendezvous procedures.

Spacecraft attitude can be controlled about three axes: pitch, roll, and yaw. A mode select switch permits selection of either automatic or manual control. An attitude hand controller, located for use by either pilot, is used for manual attitude control.

Translation control is provided along the longitudinal, vertical, and lateral spacecraft axes. Either of two maneuver hand controllers may be used for manual translation control. No provision is made for automatic control.

Three types of target vehicles are provided for the rendezvous missions: the Agena, the Rendezvous Evaluation Pod (REP), and the Augmented Target Docking Adapter (ATDA). Certain functions within the Agena or the ATDA can be controlled through the Command Link of the Guidance and Control System.

In rendezvous spacecraft, the Guidance and Control System is made up of eight individual systems or subsystems. They are:

- a. Attitude Control and Maneuver Electronics (ACME)
- b. Inertial Guidance System (IGS)
- c. Horizon Sensors

# PROJECT GEMINI

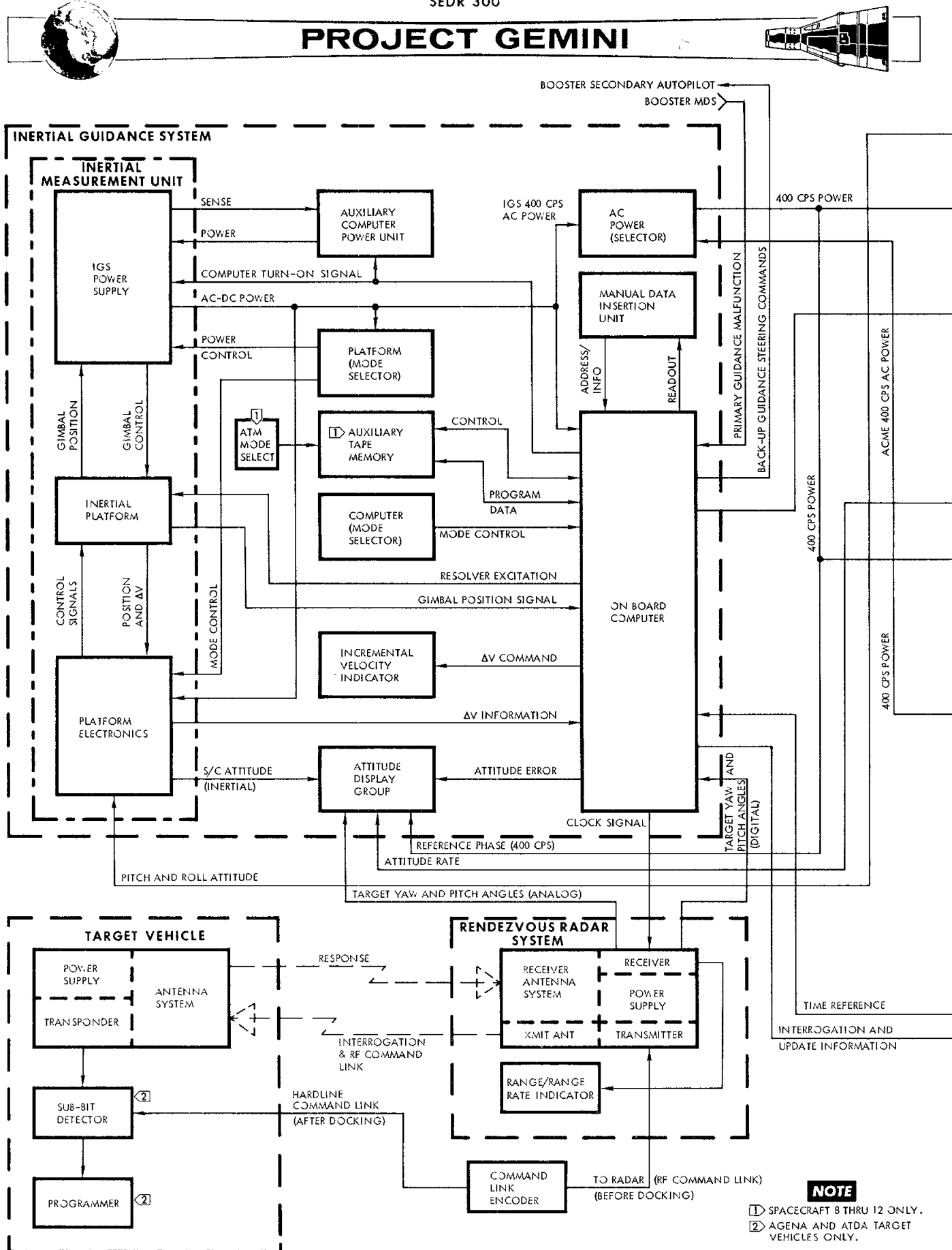

**NOTE**

- ① SPACECRAFT 8 THRU 12 ONLY.
- ② AGENA AND ATDA TARGET VEHICLES ONLY.

Figure 8-1 Guidance and Control Functional Block Diagram (Sheet 1 of 2)

# PROJECT GEMINI

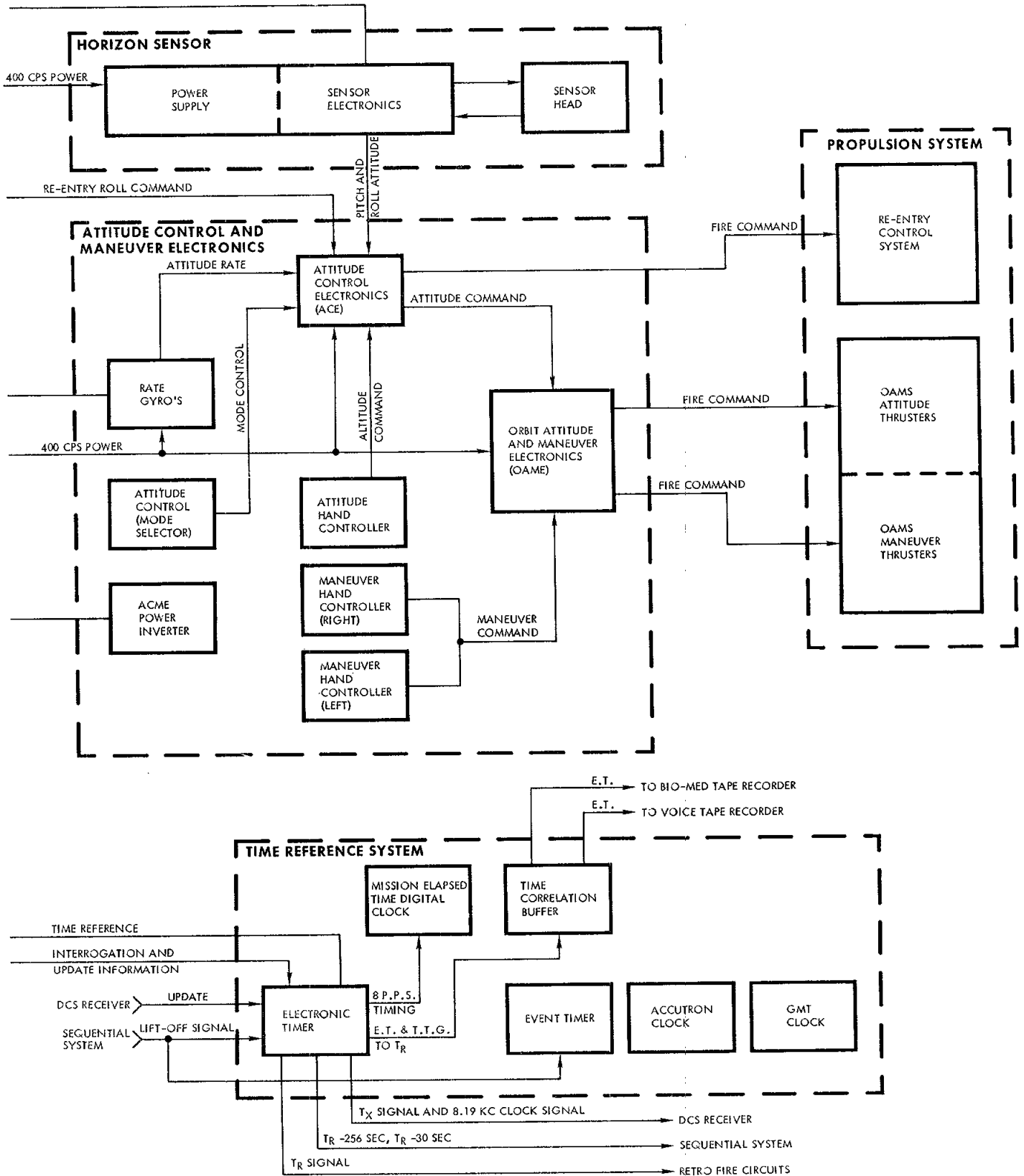

Figure 8-1 Guidance and Control Functional Block Diagram (Sheet 2 of 2)



# PROJECT GEMINI



- d. Rendezvous Radar System
- e. Command Link
- f. Rendezvous Evaluation Pod (REP)
- g. Time Reference System (TRS)
- h. Propulsion System

## SYSTEM FUNCTIONS

The various guidance and control systems are all functionally related. The functional relationship between each of the systems is illustrated in Figure 8-1.

### Attitude Control and Maneuver Electronics

The Attitude Control and Maneuver Electronics system converts input signals to thruster firing commands for the Propulsion System. Input signals to ACME are provided by the attitude hand controller, the IGS, or the horizon sensors depending on the mode of operation.

### Inertial Guidance System

The Inertial Guidance System provides inertial attitude and acceleration information, guidance computations, and displays. The inertial attitude and acceleration information is used for computations and display purposes. Computations are used for back-up ascent guidance, rendezvous guidance and re-entry guidance. Displays are utilized by the crew for reference information and as a basis for manual control.



# PROJECT GEMINI



## Horizon Sensors

The Horizon Sensors provide a reference to the earth local vertical during orbit. Pitch and roll error signals are supplied to ACME for automatic attitude control and to the IGS for platform alignment.

## Rendezvous Radar

The Rendezvous Radar provides target range, range rate, and angle information. Target information is used for rendezvous computations and for display purposes. A radar indicator displays target range and range-rate information. Target elevation and yaw angles are selectable for display on the attitude indicator.

## Command Link

The Command Link provides a control capability over the Agena or ATDA target vehicle. Coded commands, transmitted either through the radar or the umbilical, allow the pilot to activate or de-activate the various systems of the target vehicle.

## Rendezvous Evaluation Pod

The Rendezvous Evaluation Pod is the target for a simulated rendezvous mission. The pod is carried into orbit in the equipment adapter section of Gemini. Once in orbit, the pod is ejected and its systems activated. A radar transponder and acquisition lights in the pod allow the Gemini pilots to perform rendezvous exercises.



# PROJECT GEMINI



## Time Reference System

The Time Reference System provides a time base for all guidance and control functions. Time is displayed for pilot reference in both clock and digital form. The TRS also provides timing signals to the computer and the Sequential System.

## Propulsion System

The Propulsion System provides the thrust required for spacecraft maneuvers. Thrusters are provided for both translational and attitude control. Firing commands for the Propulsion System are provided by ACME.

## GUIDANCE AND CONTROL MISSION

The functions of the Guidance and Control System are dependent on mission phase. The mission is divided into five phases for explanation purposes. The phases are: pre-launch, launch, orbit, retrograde, and re-entry.

## Pre-launch Phase

Pre-launch phase is utilized for check-out and programming of guidance and control systems. Parameters required for insertion in the desired orbit are inserted in the computer. The IMU is aligned to the local vertical and the desired launch azimuth. Power is turned on to the various systems, and mode selectors are placed in their launch position. Check-out and parameter insertion are performed in the last 150 minutes prior to launch.

# PROJECT GEMINI

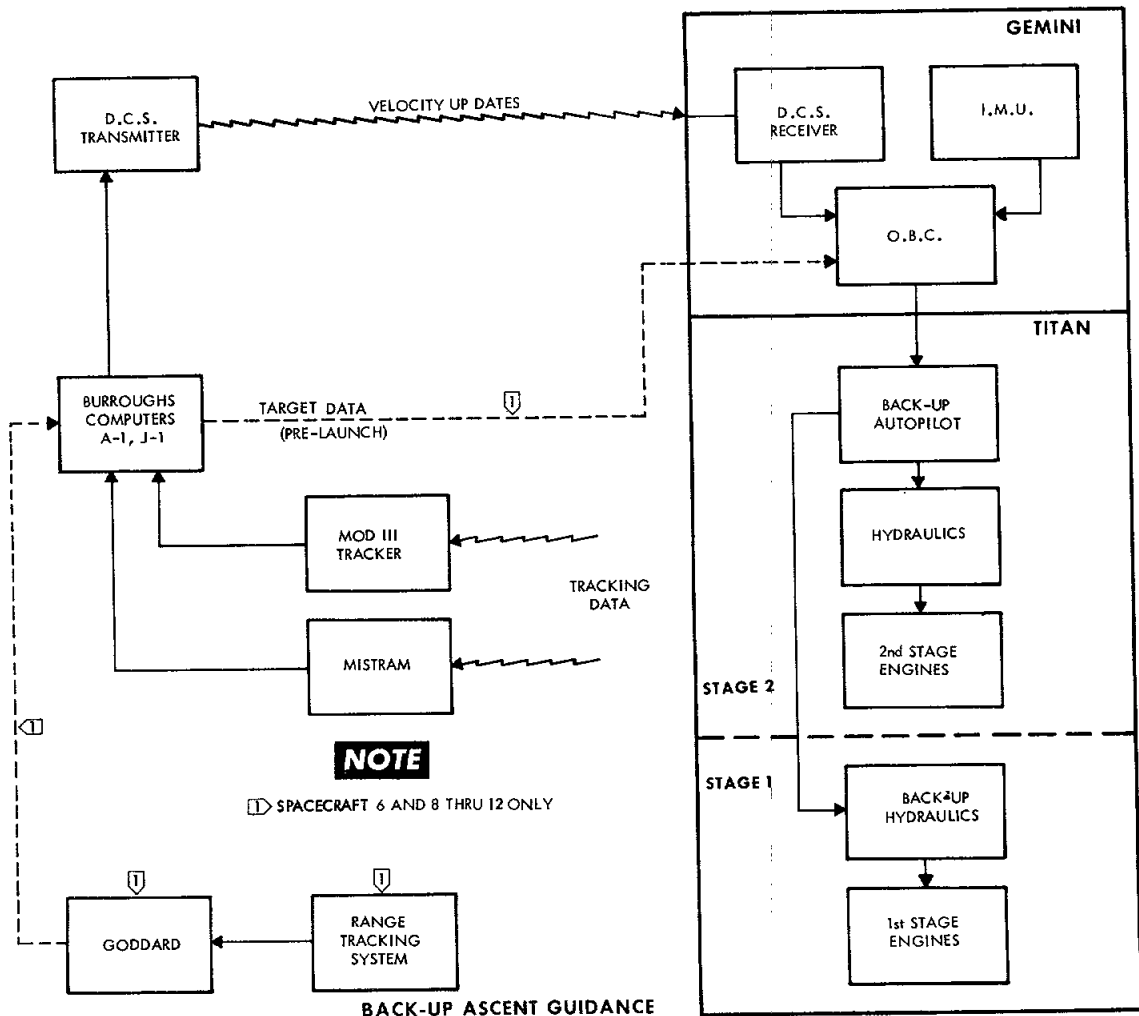
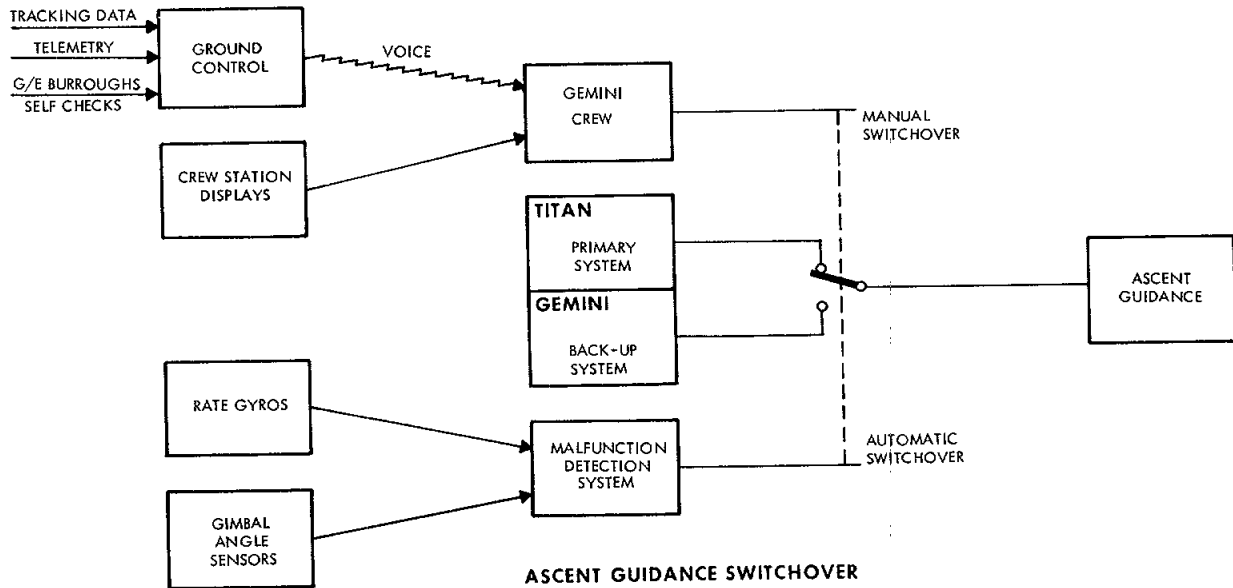

Figure 8-2 Gemini Ascent Guidance (Back-Up)



# PROJECT GEMINI



## Launch Phase

Guidance and control from lift-off through SSECO is provided by the booster guidance system. However, in case of booster guidance malfunction the IGS can assume control. Provision is made for either automatic or manual switchover to back-up (Gemini) guidance. Figure 8-2 indicates both methods of switchover and the back-up method of controlling the booster during ascent. The IGS monitors attitude and acceleration parameters throughout the launch phase. Ground tracking information is used to continuously update computer parameters. At SSECO, the remaining velocity required for insertion is displayed. The command pilot will, after separation, use the Propulsion System to increase spacecraft velocity as required for insertion in the desired orbit. Insertion will take place approximately 580 miles down range at an inertial velocity of approximately 25,770 feet per second.

## Orbit Phase

Orbit phase is utilized for checkout and alignment of systems, rendezvous maneuvers and preparation for retrograde and re-entry. Immediately after insertion a series of system checks will be performed to assure the capability of guidance and control systems. Guidance computations and measurements are checked for accuracy against ground tracking information. Systems are updated and aligned by ground command or by the pilot. After completion of system checks, the catch-up and rendezvous maneuvers can be performed. During the final orbit, guidance and control systems are re-aligned in preparation for retrograde and re-entry.



# PROJECT GEMINI



## Retrograde Phase

Retrograde phase begins approximately five minutes before retrofire. The computer is placed in re-entry mode and begins collecting data for re-entry computations. The Time Reference System provides indications at  $T_R-256$  seconds,  $T_R-30$  seconds, and  $T_R$ . At  $T_R-256$  seconds, a minus 16 degree bias is placed on the pitch attitude needle. The Propulsion System is switched from orbit attitude and maneuver to re-entry control. Spacecraft attitude is controlled manually during retrograde. Retrograde acceleration and attitude are monitored by the IGS, and velocity changes are displayed for reference.

## Re-Entry Phase

Re-entry phase begins immediately after retrofire. The event timer counts through zero at retrograde and will be counting down from sixty minutes during re-entry phase. After retrofire, the retrograde adapter and horizon scanner heads are jettisoned. Shortly after retrograde, the pilot orients the spacecraft to re-entry attitude ( $0^\circ$  pitch,  $180^\circ$  roll,  $0^\circ$  yaw). Re-entry attitude is held until the computer re-entry program starts. At approximately 400,000 feet altitude, the computer re-entry program starts, and the pilot has a choice of manual or automatic control. For manual control, the pilot selects RE-ENT RATE CMD. For automatic control, the RE-ENT mode is utilized. In the automatic mode, the computer controls spacecraft roll attitude. For either mode of control, the flight director is referenced to the computer and indicates computed attitude commands. The purposes of the computer re-entry program are to control the point of touchdown and to control re-entry heating. By controlling the spacecraft

# PROJECT GEMINI

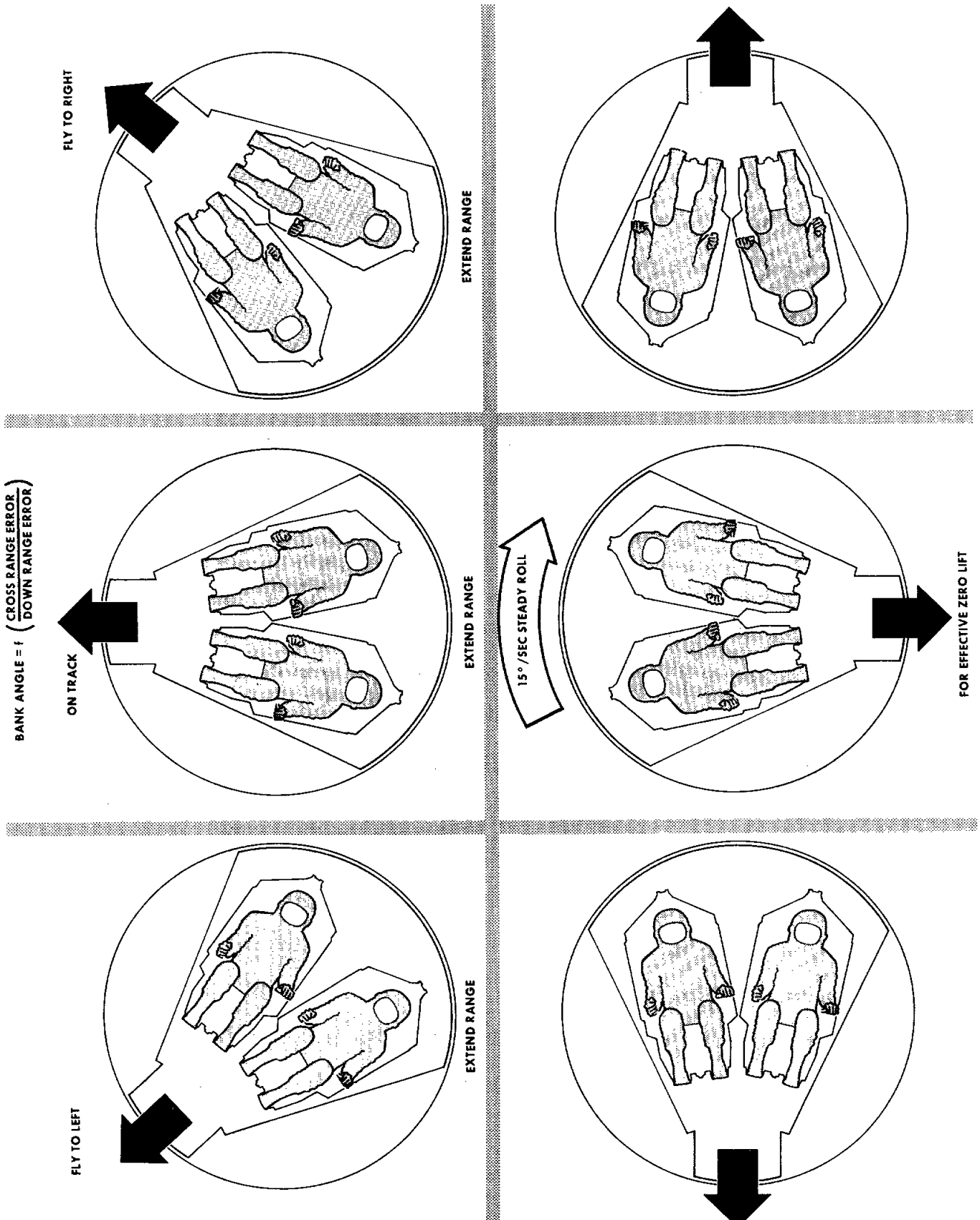
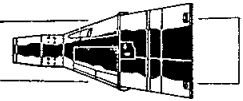

Figure 8-3 Re-entry Control



# PROJECT GEMINI



roll attitude and rate, it is possible to change the down-range touchdown point by approximately 500 miles and the cross-range touchdown by 40 miles left or right. The relationship between roll attitude or rate and direction of lift is illustrated in Figure 8-3. The roll control starts at approximately 400,000 feet and ends at 90,000 feet. Re-entry phase ends at 80,000 feet when the computer commands an attitude suitable for drogue chute deployment.

# ATTITUDE CONTROL AND MANEUVERING ELECTRONICS

## TABLE OF CONTENTS

TITLE	PAGE
SYSTEM DESCRIPTION . . . . .	8-17
SYSTEM OPERATION . . . . .	8-17
GENERAL . . . . .	8-17
FUNCTIONAL OPERATION (ACME) . . . . .	8-18
MODE OPERATION . . . . .	8-21
SYSTEM UNITS . . . . .	8-30
ATTITUDE CONTROL ELECTRONICS (ACE) . . . . .	8-30
ORBIT ATTITUDE AND MANEUVER ELECTRONICS (OAME) . . . . .	8-38
RATE GYRO PACKAGE (RGP) . . . . .	8-39
POWER INVERTER PACKAGE . . . . .	8-42

# PROJECT GEMINI

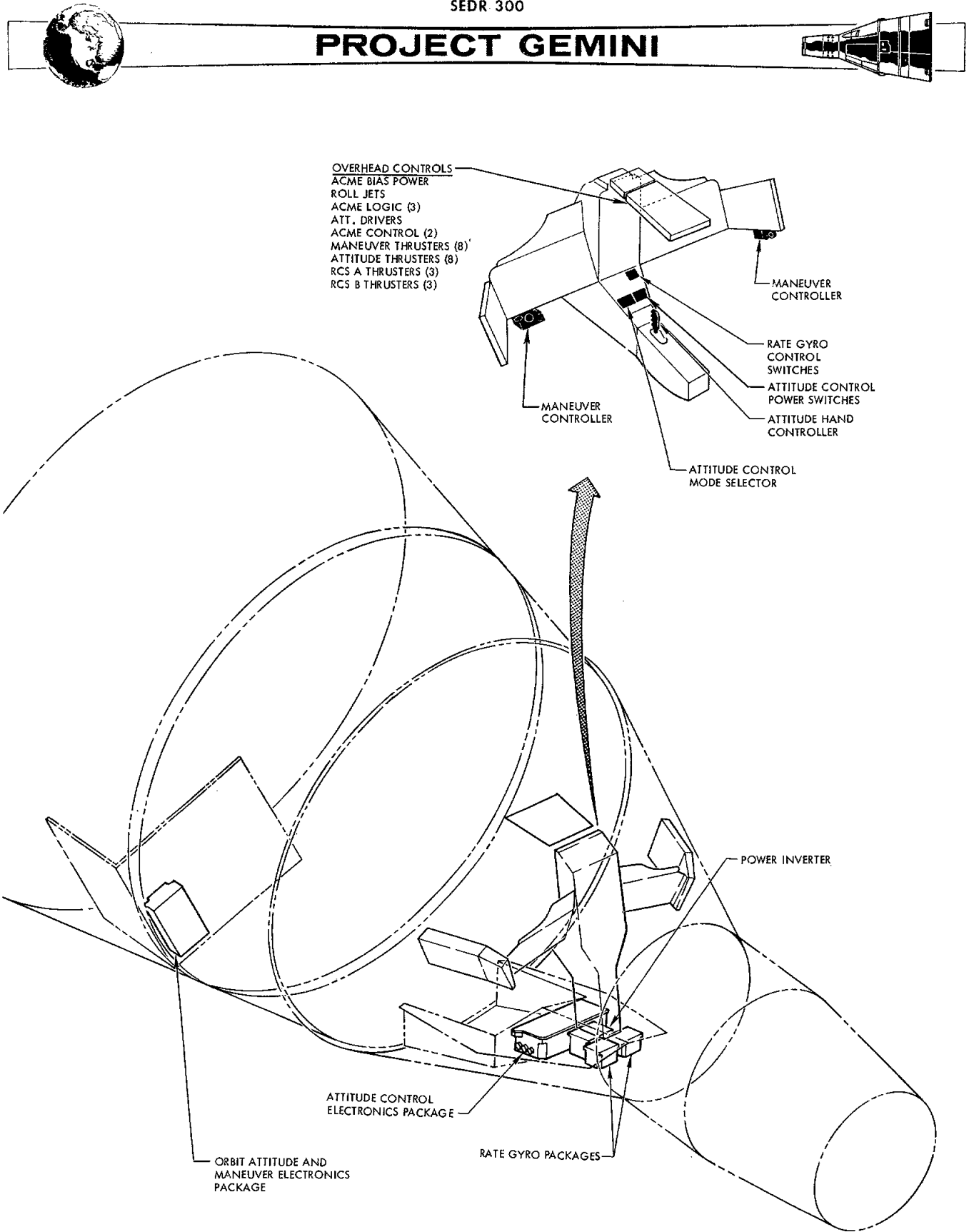

Figure 8-4 Attitude Control and Maneuver Electronics



# PROJECT GEMINI



## ACME SYSTEM

### SYSTEM DESCRIPTION

The Attitude Control and Maneuver Electronics (ACME) System (Figure 8-4) provides the control circuitry to attain and/or maintain a desired spacecraft attitude or velocity. The ACME accepts signal inputs from the attitude hand controller, horizon sensors, platform, or computer; processes the signal(s); and applies a firing command to the appropriate Propulsion System solenoid valves. ACME is composed of four separate subsystems: Attitude Control Electronics (ACE), Orbit Attitude and Maneuver Electronics (OAME), a power inverter and two identical rate gyro packages. The ACE, power inverter and rate gyro packages are installed in the center bay of the re-entry module. The OAME package is located in the equipment section of the adapter. Total weight of the ACME System is approximately 40 pounds.

The ACME provides the capability of automatic or manual attitude control, with seven separate, selectable modes of operation. The horizon sensor, the inertial platform or the computer provide the reference for automatic modes of operation. The attitude hand controller provides the input signals for manual modes of attitude control. The maneuver hand controller supplies signals to the maneuver solenoid valves for translational maneuvers.

### SYSTEM OPERATION

#### GENERAL

The ACME provides attitude control, automatic or manual, during all flight phases of the spacecraft mission. Rate gyro inputs to ACE are used to dampen spacecraft attitude rates. Signal inputs are modified by ACME logic and converted to firing commands for the Propulsion System.



# PROJECT GEMINI



The ACME functional modes of the control are horizon scan, rate command, direct, pulse, re-entry rate command, re-entry, and platform. Each mode provides a different signal input (or combination of inputs) to be processed by ACE for routing to Re-entry Control System (RCS) or OAME solenoid valve drivers. The modes of control are separated into two basic types; automatic attitude control modes (horizon scan, re-entry and platform) and manual attitude control modes (rate command, direct, pulse and re-entry rate command). Display information from control panel indicators is used as reference when manual control modes are utilized. Reference information is supplied by guidance and control subsystems and consists of the following: attitude, attitude rates, bank angle and roll commands (from the attitude display group), velocity increments (from the incremental velocity indicator), and range and range rate (from the radar indicator). The control panels also contain the control switches necessary for selection of ACME power and logic circuits and attitude control mode, along with selection switches for the various ACME redundant options.

## FUNCTIONAL OPERATION (ACME)

### Attitude Control (Figure 8-5)

Commands or error signals from the computer, platform, horizon sensors, rate gyros and attitude hand controllers are converted by the ACE into thruster firing commands. The firing commands are routed by a valve driver select system to the RCS or the Orbit Attitude Maneuver System (OAMS) attitude solenoid valve drivers.

Signal inputs to the ACE are of three types: ac attitude signals, dc attitude signals, and ac attitude rate signals. These signals are selected and distributed by ACE mode logic switching circuits. Selected signals are channeled through the proportional circuitry which amplifies, sums and demodulates the signal inputs

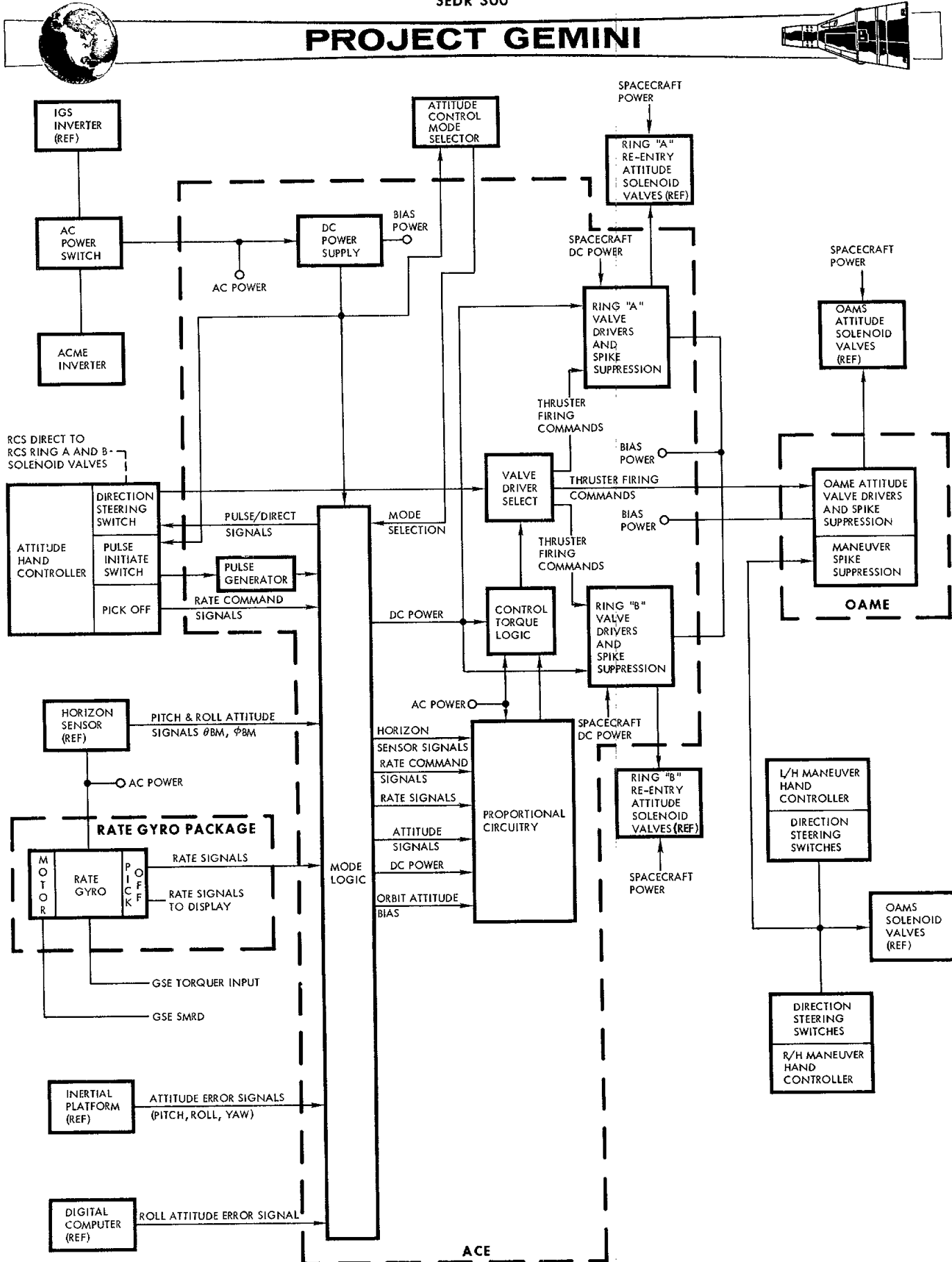

Figure 8-5 ACME Functional Block Diagram



# PROJECT GEMINI



into a dc analog output. Horizon sensor (dc attitude) signals are converted to ac prior to entering the proportional circuitry. The analog signals are then converted by control torque logic switch circuitry to a positive or negative discrete, the output consisting of either positive or negative thruster firing commands. These commands are routed from the valve driver select system to the RCS (ring A and/or ring B) valve drivers, or to the OAMS attitude valve drivers for a firing command to the appropriate thruster valves. Zener diode spike suppression circuits limit the voltages generated across the solenoid valves during current interruptions.

## Attitude Hand Controller

Spacecraft attitude may be manually controlled by use of the attitude hand controller and a visual reference. Controller outputs are rate, pulse or direct command signals, (plus a hand controller position output to telemetry) depending upon the control mode selection. Output signals are produced by positive or negative handle movements from the centered position. Rate signals produced are proportional to the amount of control displacement from a center deadband. Direct and/or pulse signals are produced when the hand controller is displaced past a preset threshold or deadband. Pulse signals trigger a pulse generator in ACE to produce a calibrated on time. The control handle must be returned to a neutral position before another single pulse can be commanded. Details of each control mode may be found in the MODE OPERATION paragraph.

## RCS Direct

The RCS direct mode is selectable as an alternate means of manually firing the RCS thrusters, and by-passes the ACE. The DIRECT position of each of the RCS RING A or RING B switches provides a circuit ground to l2 attitude hand con-



## PROJECT GEMINI



troller RCS direct switches. The ground is then applied directly to the required thruster solenoid valves through appropriate hand controller displacements. This RCS mode of operation is intended for backup or emergency control only.

### Maneuver Hand Controllers

Translational maneuvers of the spacecraft in the horizontal, longitudinal and vertical planes may be commanded by either of the maneuver hand controllers. Displacement of a hand controller, from the centered or neutral position in any of the six translational directions produces a direct-on command to the respective solenoid valves.

### Rate Gyros

The function of the rate gyro package is to sense angular rate about the pitch, yaw and roll axes of the spacecraft and provide an output signal proportional to that sensed rate. Selection of certain control modes provides gyro inputs to ACE for angular rate damping. Additional information concerning the rate gyros may be found in the paragraph under SYSTEM UNITS RATE GYRO PACKAGE.

### Power Inverter

The power inverter provides the ACME and horizon sensors with ac power. Spacecraft dc power is converted to 26V, 400 cps (The IGS inverter provides the primary source of ac excitation). The ACME inverter is utilized when the Inertial Measurement Unit (IMU) is off. Additional information regarding the power inverter may be found in the paragraph under SYSTEM UNITS POWER INVERTER PACKAGE.

### MODE OPERATION

Control of spacecraft attitude is accomplished through the selection of seven



# PROJECT GEMINI



functional control modes. Each control mode is utilized for a specific purpose or type of ACME operation in conjunction with various mission phases. Each mode provides either automatic or manual spacecraft control through the switching of input signals to ACE. In addition, the mode logic circuits de-energize all unused circuits within the ACE during use of the horizon scan mode to conserve power. Switching is performed by transistors at the signal level and by relays at the power level. The operation of each control mode is explained in the following.

## Direct Mode ( $M_1$ )

In this mode, thruster firing commands are applied directly to the RCS or OAME attitude solenoid valve drivers by actuation of the attitude hand controller direct switches (Figure 8-6). Selection of the direct mode applies a bias voltage to a transistor designated ground switch A. Conduction of the transistor completes a circuit to ground which is common to one side of the hand controller direct switches. The transistor remains on as long as the direct mode is selected. Six normally-open switch contacts provide the command signals in the pitch, yaw and roll axes and will close when the hand controller is moved beyond a preset threshold (2.5 degrees) of handle travel. Deflection in the desired direction applies a ground from switch A directly to the valve driver relative to that direction which, in turn, fires the proper thruster(s). Thrusters continue firing as long as the hand controller is displaced beyond the 2.5 degree threshold. This mode of operation is optional at all times.

## Pulse ( $M_2$ )

In this mode, the attitude commands initiated by hand controller displacement

# PROJECT GEMINI

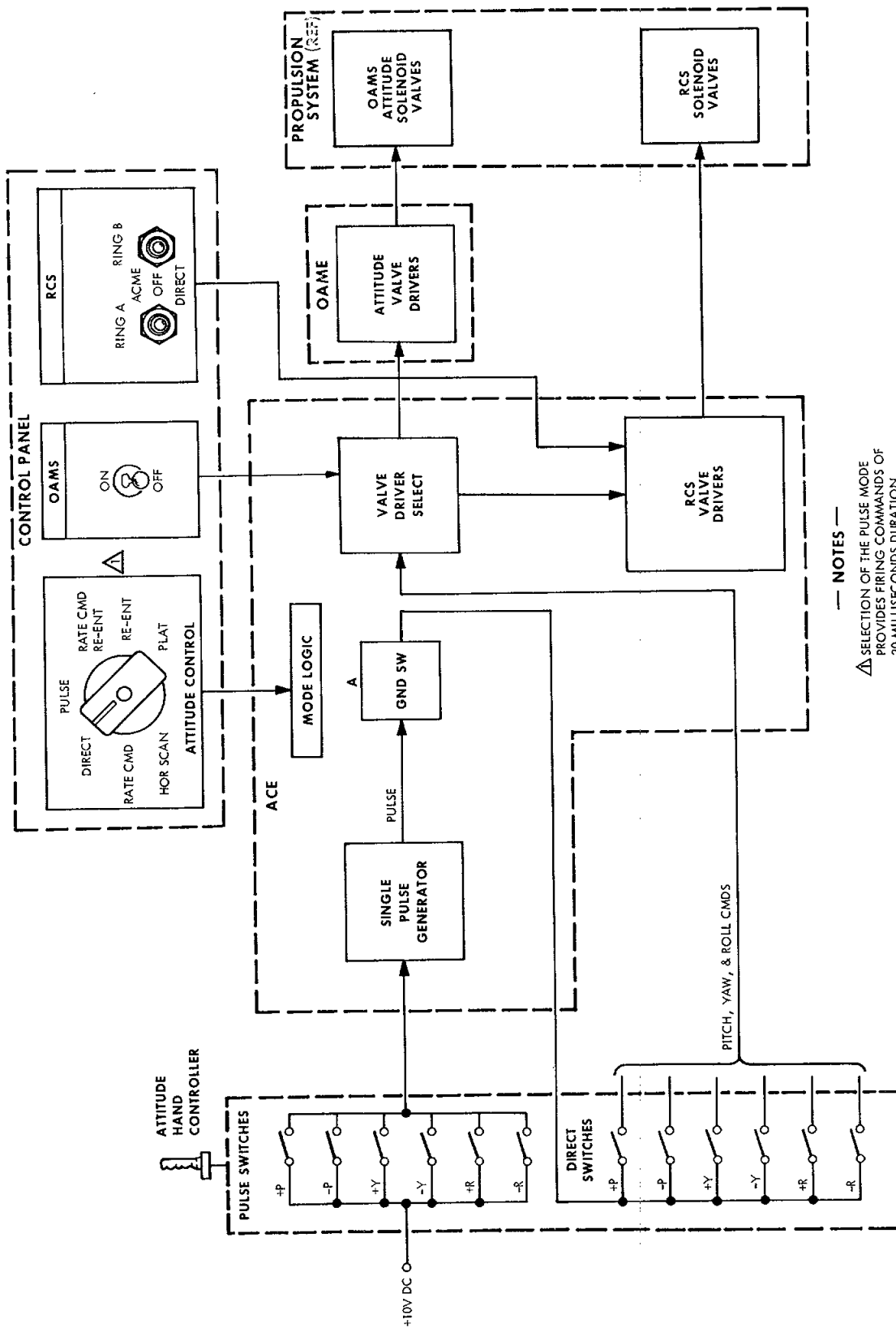
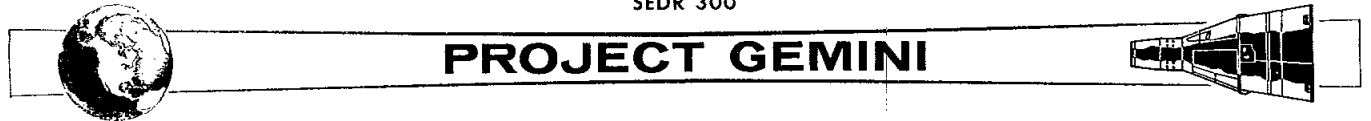

— NOTES —  
 Δ SELECTION OF THE PULSE MODE PROVIDES FIRING COMMANDS OF 20 MILLISECOND DURATION.  
 LOGIC FUNCTION  
 A = GND (DIRECT SELECT OR COMMAND PULSE)

Figure 8-6 ACME Simplified Block Diagram (Direct & Pulse Command Modes)



# PROJECT GEMINI



fire a single pulse generator in the ACE (Figure 8-6). The pulse mode logic activates the generator, allowing it to fire for a fixed duration when a pulse command is received. Commands originate every time one of the six normally-open pulse switch contacts of the hand controller is closed. This triggers the generator and applies a bias voltage pulse for a 20 millisecond duration to ground switch A. This ground is then applied to the RCS or OAME attitude valve drivers, through the actuated hand controller direct switches, as a command for thruster firing. Commands may be initiated in the pitch, yaw or roll axis by moving the control handle in the desired direction beyond a preset threshold (3.5 degrees). Thrusters fire for 20 milliseconds each time the handle is displaced beyond 3.5 degrees. This mode is optional at all times and will normally be used during platform alignment.

## Rate Command Mode ( $M_2$ )

In this mode, spacecraft attitude rate about each axis is proportional to the attitude hand controller displacement from the neutral deadband (Figure 8-7) (The output remains at zero for displacements less than 1 degree of handle travel, providing a non-operational area or deadband). Command signals, generated by handle displacements, are compared with rate gyro outputs, and when the difference exceeds the damping deadband, thruster firing occurs. Signals originate from potentiometers in the hand controller and outputs are directly proportional to handle displacement. A maximum command signal to ACE produces an angular rate of 10 degrees/second about the pitch and yaw axis and 15 degrees/second about the roll axis.

Automatic, closed-loop stabilization of spacecraft rates is provided by the sensing of angular rates by the rate gyro package. With the absence of hand



## PROJECT GEMINI



controller command signals, spacecraft rates about each axis are dampened to within  $\pm 0.2$  degrees/second with OAME attitude control and to within  $\pm 0.5$  degrees/second with RCS attitude control. Output signals from the rate gyros are used to produce fire commands until the rate signal is within the damping deadband. This mode is optional at all times and will normally be used during translational thrusting or attitude changes.

### Horizon Scan Mode (M<sub>4</sub>)

In this automatic command mode, horizon sensor outputs (pitch and roll) are processed by the ACE to orient and hold the spacecraft within a desired attitude deadband during orbit (Figure 8-8). Pitch attitude is maintained automatically to within  $\pm 5$  degrees of the horizon sensor  $-5$  degree output, and roll attitude is maintained automatically to within  $\pm 5$  degrees of the horizon sensor zero degree null. Control about the yaw axis is accomplished by commands from the attitude hand controller in the same manner as in the pulse mode. Pulse control about the pitch and roll axes is also available to supplement the automatic control. A  $-5$  degree bias voltage is summed with the pitch input to the ACE to maintain the  $5$  degree pitch down orientation. When the attitude error (pitch or roll) exceeds the  $5$  degree control deadband, the output of the ACE on-off logic is a pulse firing command. The pulse time is 18 milliseconds and the pulse repetition frequency is dependent upon how much the attitude error exceeds the  $5$  degree deadband. A lag network in this mode provides a pseudo rate feedback for rate damping without having to use the power-consuming rate gyros.

### Re-entry Mode (M<sub>5</sub>)

In this automatic command mode, spacecraft angular rates about the pitch and yaw

PROJECT GEMINI

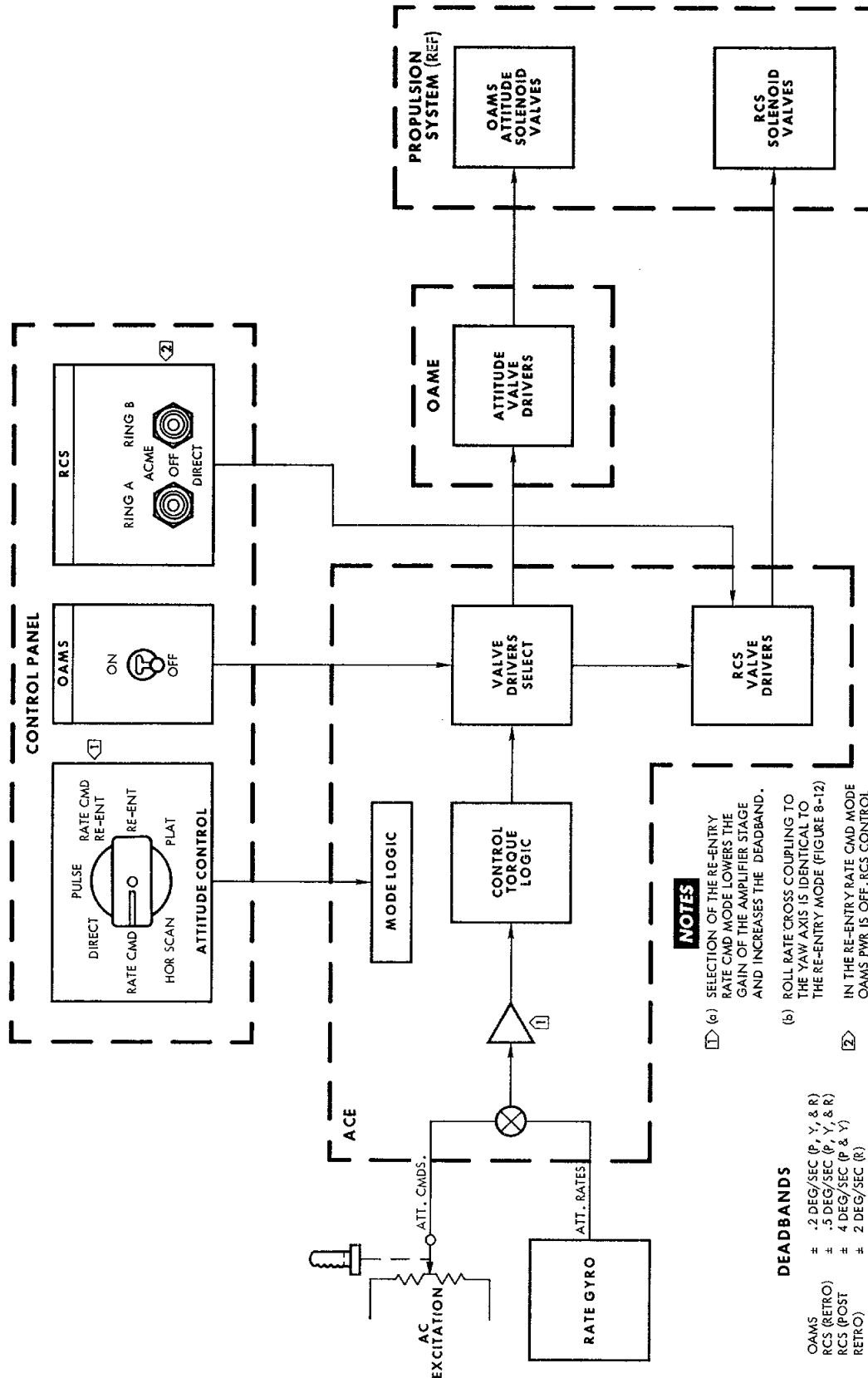

Figure 8-7 ACME Simplified Block Diagram (Rate Cmd. and Re-entry Rate Cmd. Modes)

# PROJECT GEMINI

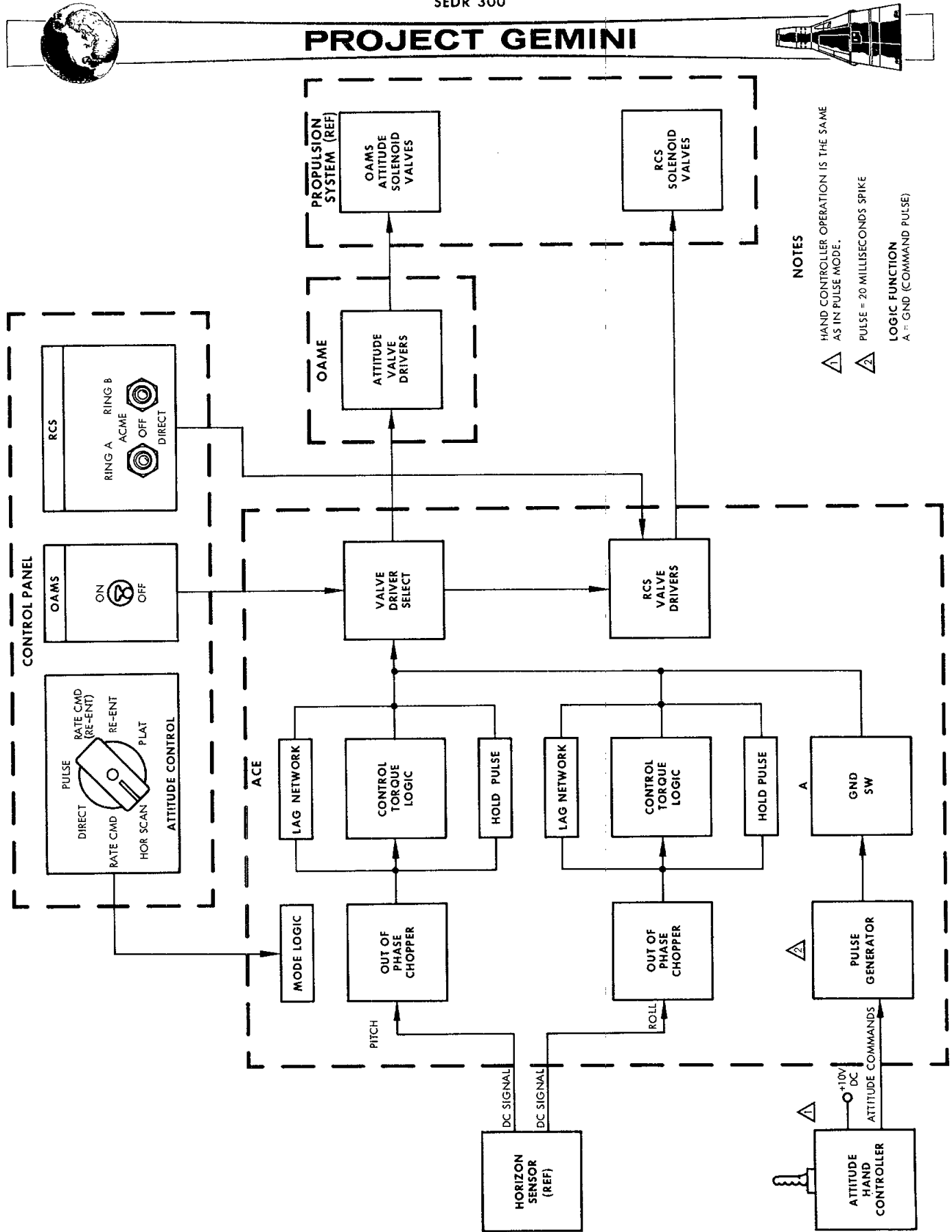

Figure 8-8 ACME Simplified Block Diagram (Horizon Scan Mode)



# PROJECT GEMINI



axes are dampened to within  $\pm 4$  degrees/second and to within  $\pm 2$  degrees/second about the roll axis (Figure 8-9). Roll attitude is controlled to within  $\pm 2$  degrees of the attitude commanded by the digital computer input to ACE. The computer roll input to ACE consists of either a bank angle attitude command or a fixed roll rate command depending upon the relationship between the predicted touchdown point and the desired touchdown point. Roll to yaw crosscoupling is provided to minimize the spacecraft lift vector.

## Re-entry/Rate Command Mode (M<sub>5</sub>D)

In this manual command mode, spacecraft rates are controlled by rate commands from the attitude hand controller. With the exception of wider deadbands, the method is identical to the rate command mode with the addition of roll-yaw rate crosscoupling. Angular rate damping about the three axes is identical to the re-entry mode. The computer bank angle and roll rate commands do not automatically control the spacecraft but are provided on the control panel displays as a reference for initiating manual re-entry roll commands.

## Platform (M<sub>6</sub>)

This attitude control mode is used to maintain spacecraft attitude, in all three axes, with respect to the inertial platform. Spacecraft attitude is held automatically to within  $\pm 1.1$  degrees of the platform attitude. A horizontal attitude, with respect to the earth, can be held if the inertial platform is in the orbit rate or alignment mode of operation. Spacecraft attitude rates are dampened to within  $\pm 0.5$  degrees/second. The primary purpose of this mode is to automatically hold an inertial spacecraft attitude. This mode is also useful for maintaining spacecraft attitude during fine alignment of the platform (Figure 8-10).

# PROJECT GEMINI

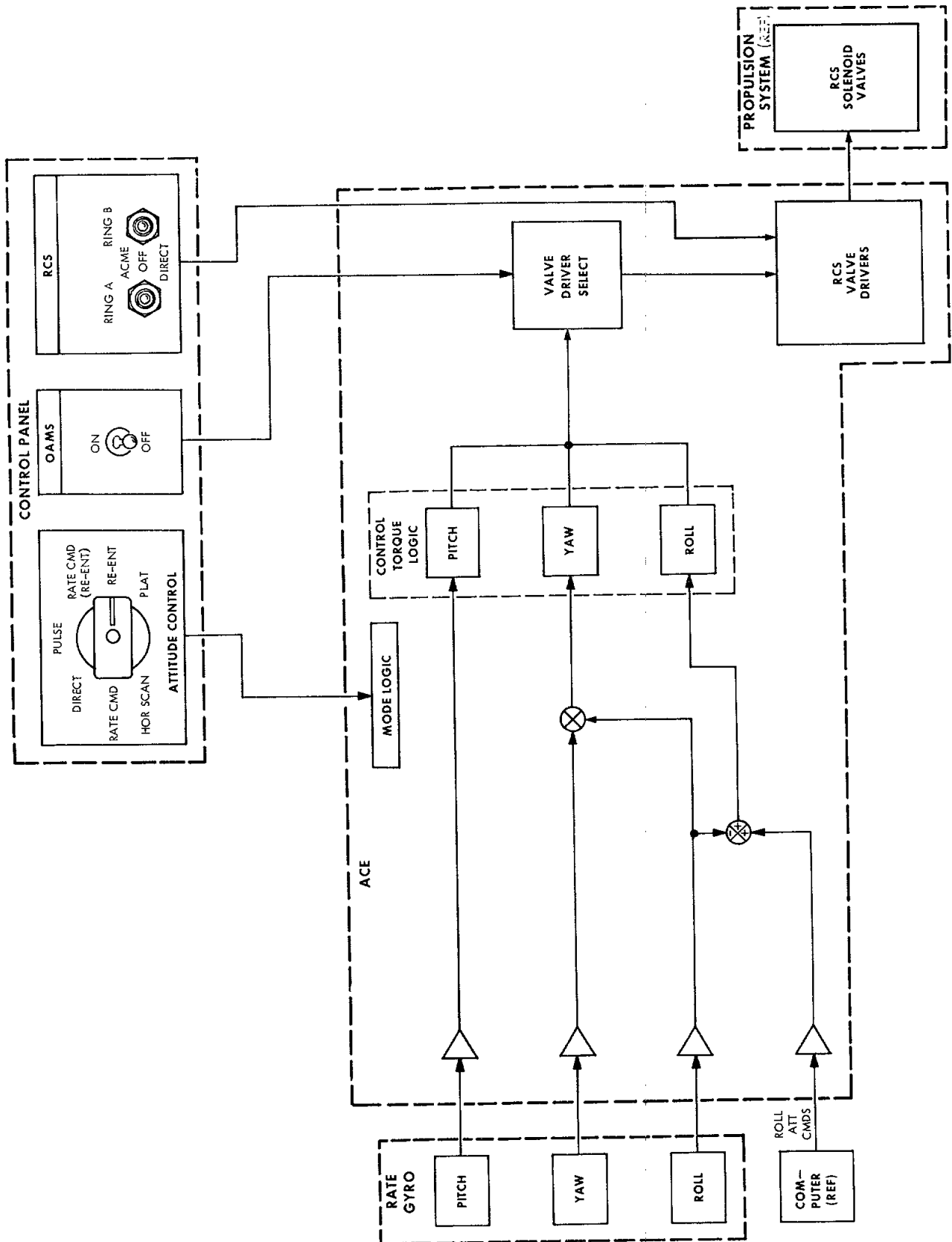

Figure 8-9 ACME Simplified Block Diagram (Re-entry Mode)



# PROJECT GEMINI



## Aborts - ACME/RCS

The rate command mode of ACME will be utilized for attitude control during all abort modes. Control over the RCS ring A and ring B switches for a mode 2 abort is automatically switched to ACME by the abort sequential relays.

## SYSTEM UNITS

### ATTITUDE CONTROL ELECTRONICS (ACE)

The ACE package (Figure 8-4) weighs approximately 17 pounds, has a removable cover and contains ten removable module boards. These boards make up the ACE logic circuitry and consist of the following: a mode logic board, an ac signal processing board, three axis logic boards, three relay boards, a power supply board (+20, +10, -10 vdc) and a lag network board. These replaceable module boards perform the signal processing for the three-axis control, and convert signal inputs into appropriate thruster firing commands. They also contain the solenoid valve driver circuits for the RCS solenoid valves.

### Functional Operation

Input signals to ACE are dependent upon attitude or attitude rate requirements of the spacecraft and are used to obtain an attitude or attitude rate correction. A functional schematic of the ACE is shown in Figure 8-11 and is sectioned to show signal processing for each of the three axes. ACE mode logic circuits are represented by the blocks at the left of the figure. The selection of an attitude control mode initiates transistor switching in the logic circuits pertaining to that mode. The appropriate input signal is then switched into the proper ACE channel for processing. Additional information on mode logic switching may be found in the Mode Logic Switching paragraph.

# PROJECT GEMINI

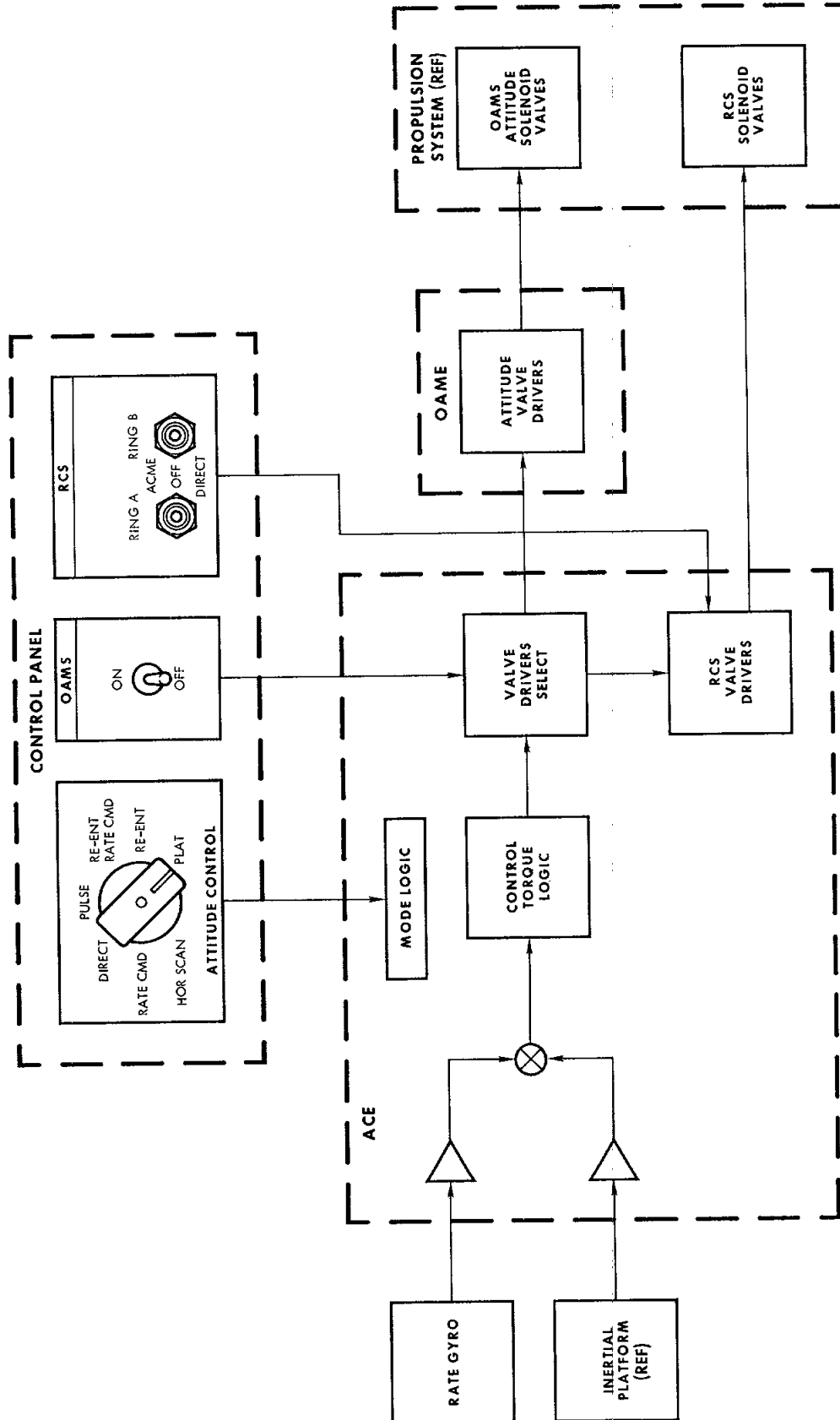

Figure 8-10 ACME Simplified Block Diagram (Platform Mode)



# PROJECT GEMINI



Proportional circuits consist of the signal amplifier stages (attitude and rate), switch amplifiers and the demodulator/filter stages. Attitude and rate signals to each of the pitch, yaw and roll channels (with the exception of horizon sensor signals) are ac and are amplified to operational levels by the attitude and rate amplifiers. The outputs are summed and fed to the switch amplifiers. The output of the switch amplifier is coupled to the demodulator stage where it is converted to a positive or negative dc analog signal. The dc signal then energizes either the positive or negative, low-hysteresis transistor switch in the control torque logic section. The switches for the pitch and yaw axes are held on for a minimum of 18 milliseconds by the minimum pulse generators. Horizon sensor dc signals are chopped and amplified by the switch amplifiers, then modulated in the same manner as ac signals.

The valve driver select circuits control power and signal distribution to OAME and RCS attitude valve drivers. To turn off the OAME control system, power is applied to de-energized relays. The normally-closed relay contacts forward the power and signal inputs to the OAME. Power may then be applied to the RCS ring A and/or ring B valve drivers for RCS attitude control. The ring A and ring B RCS valve drivers consist of relays energized by transistor relay drivers.

## Mode Logic Switching

Transistor switching provides the control for attitude mode signal selections, along with ACE power distribution in the horizon scan mode. These switches are represented by blocks in Figure 8-11. The logic function for each block is explained in the truth table at the right of Figure 8-11 as being ground or not ground. Figure 8-12 shows how mode control of signal selections is accomplished.



# PROJECT GEMINI



The transistor switches provide a grounded or not grounded condition to attitude signals, by being in a conducting or non-conducting state. Attitude reference and command signals are obtained by selecting the appropriate control mode switch position. This applies a +20 vdc bias voltage to the base of a PNP transistor, biasing it to cut off. This ungrounded state allows the desired signal to be applied to the ACE amplifiers. The mode 1 (direct), and mode 2 (pulse), and one of the M4 (horizon scan) logic switches are NPN transistors, and conduct with the application of +20 vdc. This provides a ground circuit for hand controller commands. The pulse generator signal provides the bias voltage to turn on switch A when in the pulse or orbit modes.

## Signal Processing (Figure 8-11)

The type signal selected for each mode of control can be determined by referring to the logic block in each channel and the mode logic table. The P and I blocks, through mode selections, establish the gain for rate amplifier stages.

## Attitude Signals

Inputs to the ACE are either in-phase or out-of-phase ac signals (with the exception of the dc horizon sensor input). A positive attitude displacement generates an in-phase error signal which, in turn, will command negative thrusting. A negative attitude displacement, generating an out-of-phase signal, will command positive thrusting. By referring to the logic table, it may be seen that the selection of mode 5 provides a computer roll input through the function of logic block D<sub>p</sub> and is the only attitude signal selected for an input to ACE. A roll attitude error or command signal is fed into the three-stage attitude amplifier. The amplifier output will be used to turn on the appropriate solenoid valve driver. The limiter is used to limit attitude signal amplitude. The out-

# PROJECT GEMINI

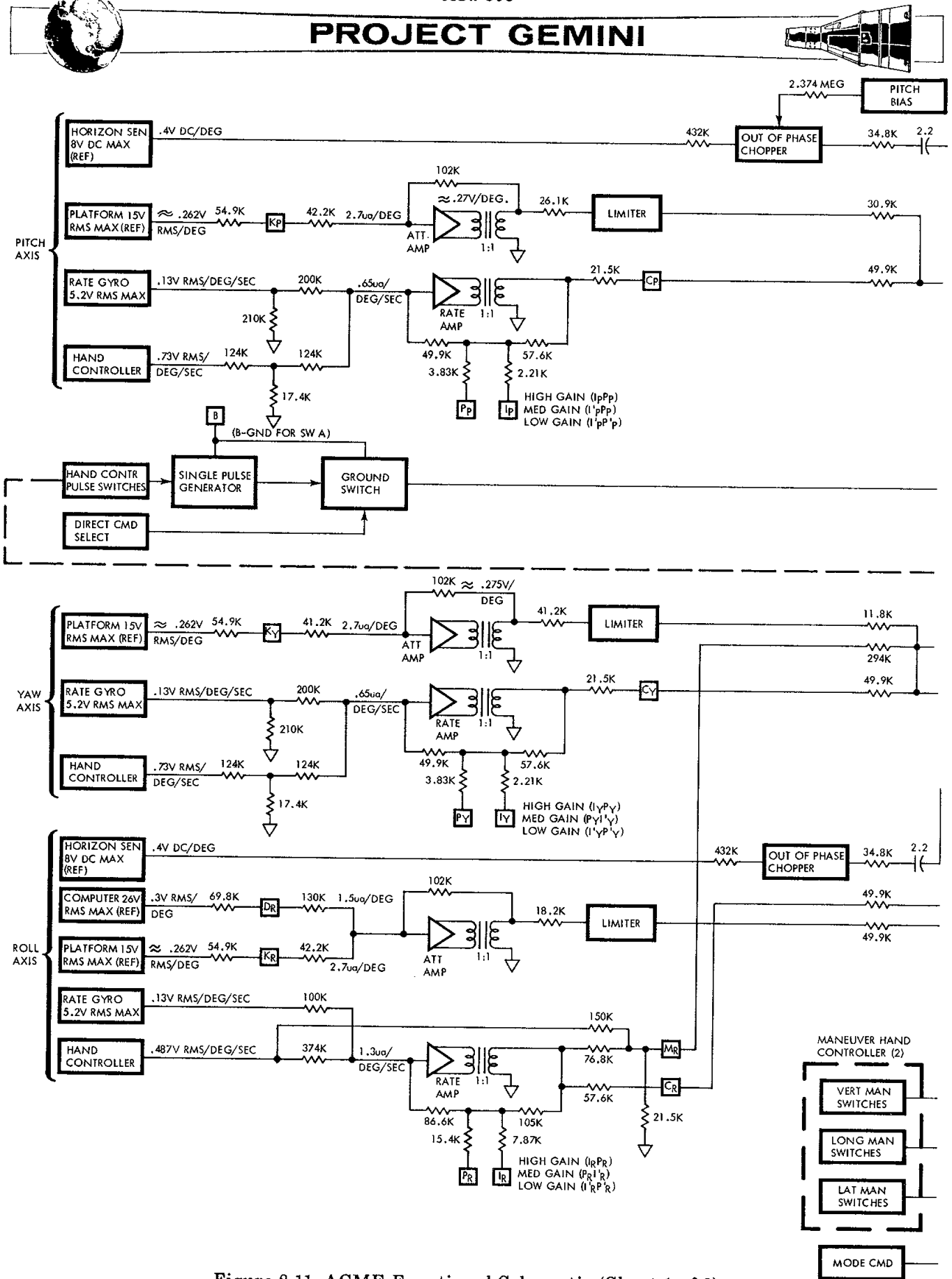
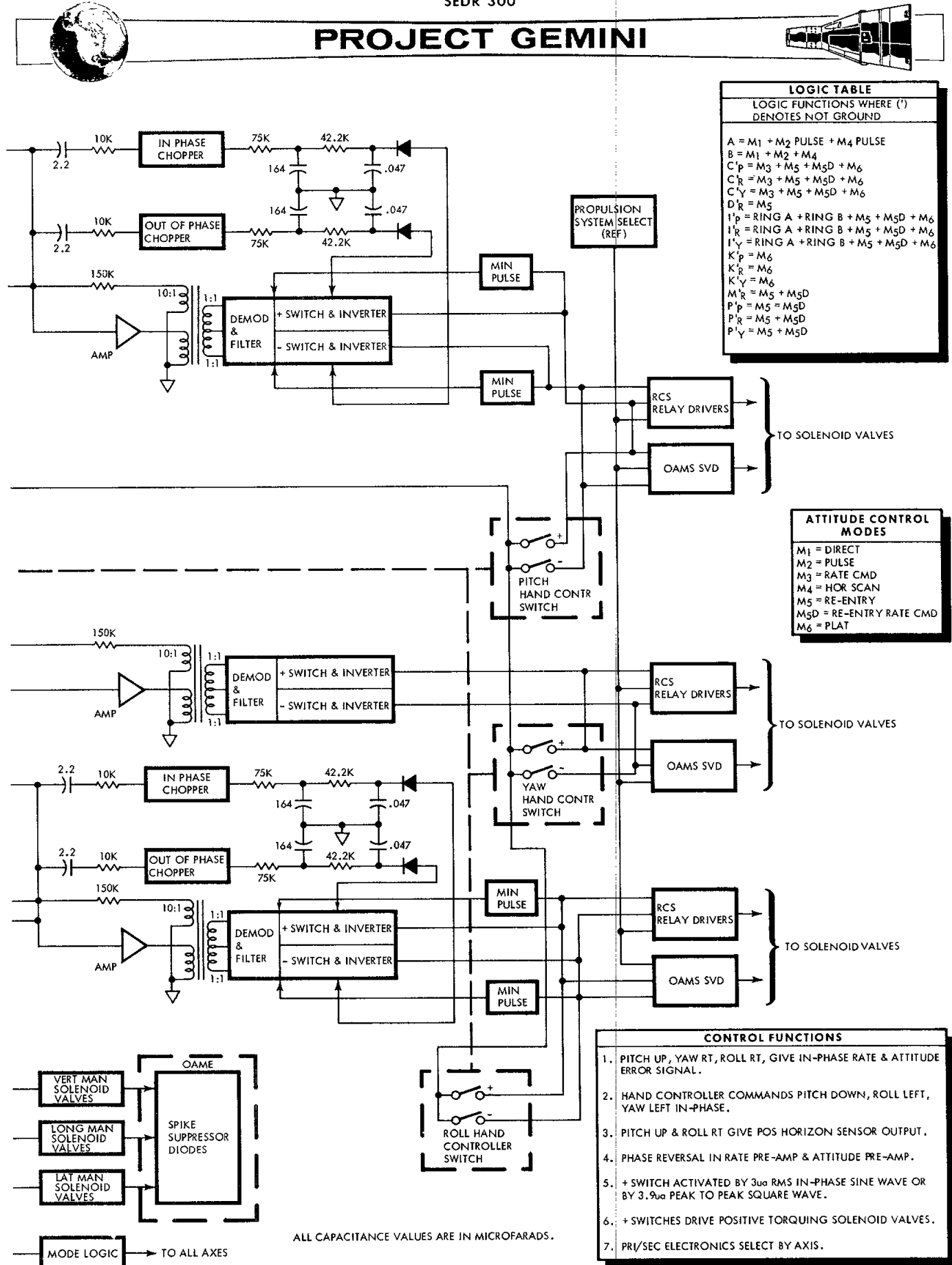

Figure 8-11 ACME Functional Schematic (Sheet 1 of 2)

# PROJECT GEMINI



LOGIC TABLE	
LOGIC FUNCTIONS WHERE (') DENOTES NOT GROUND	
A	$M_1 + M_2 \text{ PULSE} + M_4 \text{ PULSE}$
B	$M_1 + M_2 + M_4$
C <sub>P</sub>	$M_3 + M_5 + M_5D + M_6$
C <sub>R</sub>	$M_3 + M_5 + M_5D + M_6$
C <sub>Y</sub>	$M_3 + M_5 + M_5D + M_6$
D <sub>R</sub>	$M_5$
I <sub>P</sub>	$\text{RING A} + \text{RING B} + M_5 + M_5D + M_6$
I <sub>R</sub>	$\text{RING A} + \text{RING B} + M_5 + M_5D + M_6$
I <sub>Y</sub>	$\text{RING A} + \text{RING B} + M_5 + M_5D + M_6$
K <sub>P</sub>	$M_6$
K <sub>R</sub>	$M_6$
K <sub>Y</sub>	$M_6$
M <sub>R</sub>	$M_5 + M_5D$
P <sub>P</sub>	$M_5 + M_5D$
P <sub>R</sub>	$M_5 + M_5D$
P <sub>Y</sub>	$M_5 + M_5D$

ATTITUDE CONTROL MODES	
M <sub>1</sub>	DIRECT
M <sub>2</sub>	PULSE
M <sub>3</sub>	RATE CMD
M <sub>4</sub>	HOR SCAN
M <sub>5</sub>	RE-ENTRY
M <sub>5D</sub>	RE-ENTRY RATE CMD
M <sub>6</sub>	PLAT

- | CONTROL FUNCTIONS |  |
|-------------------|--|
| 1.                | PITCH UP, YAW RT, ROLL RT, GIVE IN-PHASE RATE & ATTITUDE ERROR SIGNAL.   |
| 2.                | HAND CONTROLLER COMMANDS PITCH DOWN, ROLL LEFT, YAW LEFT IN-PHASE.   |
| 3.                | PITCH UP & ROLL RT GIVE POS HORIZON SENSOR OUTPUT.   |
| 4.                | PHASE REVERSAL IN RATE PRE-AMP & ATTITUDE PRE-AMP.   |
| 5.                | + SWITCH ACTIVATED BY 3 <sub>ua</sub> RMS IN-PHASE SINE WAVE OR BY 3.9 <sub>ua</sub> PEAK TO PEAK SQUARE WAVE. |
| 6.                | + SWITCHES DRIVE POSITIVE TORQUING SOLENOID VALVES.  |
| 7.                | PRI/SEC ELECTRONICS SELECT BY AXIS.  |

ALL CAPACITANCE VALUES ARE IN MICROFARADS.

Figure 8-11 ACME Functional Schematic (Sheet 2 of 2)

# PROJECT GEMINI

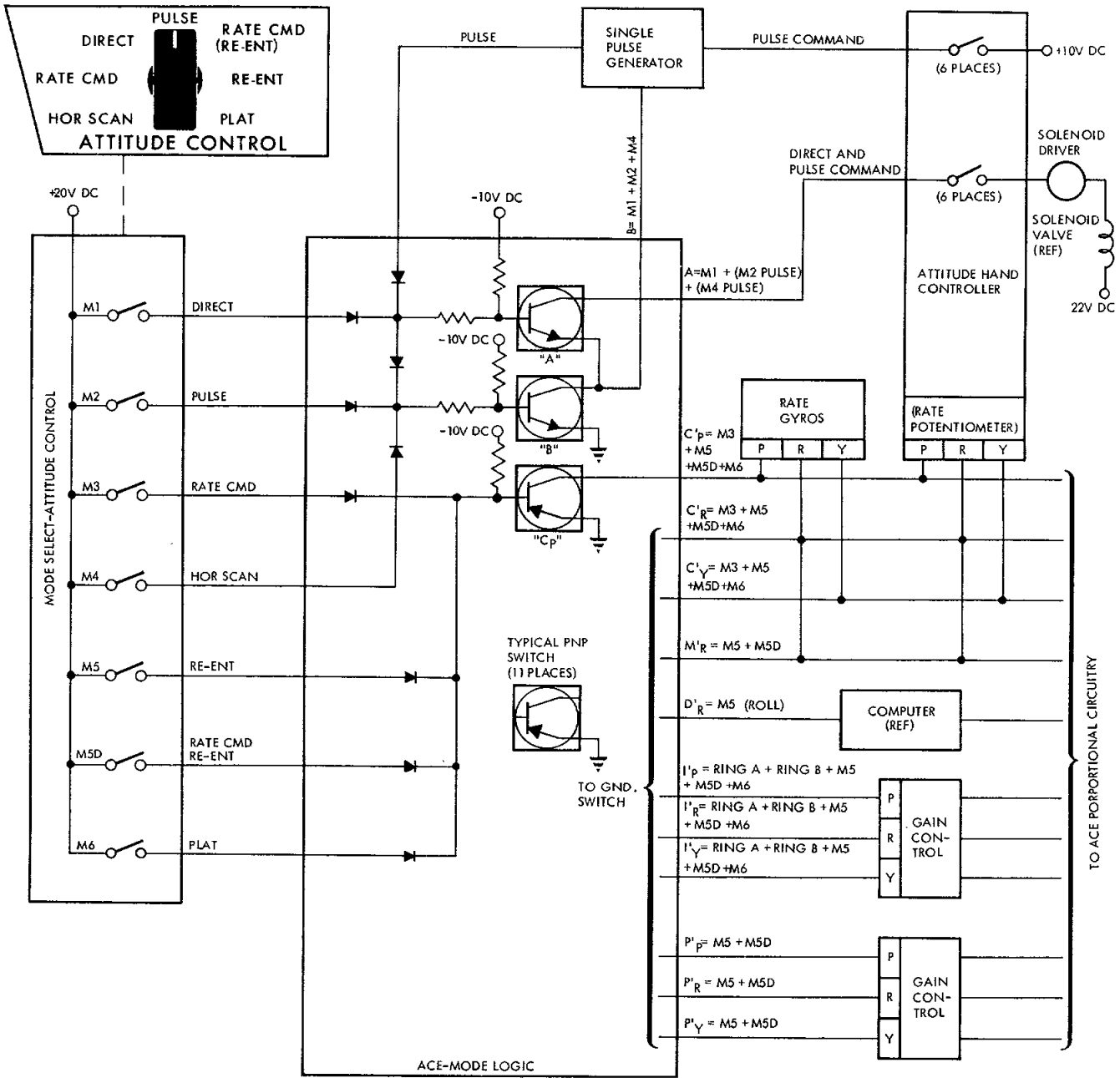

### NOTES

1. IN LOGIC FUNCTIONS (') DENOTES -NOT GROUND.
2. REFER TO FIGURE 8-11 (FUNCTIONAL SCHEMATIC) FOR ACE CIRCUITRY

Figure 8-12 ACE Mode Logic Switching-Attitude Control



# PROJECT GEMINI



put of the three-stage switch amplifier is transformer coupled to either the in-phase or the out-of-phase section of the demodulator stage. The output of the demodulator stage is a full-wave rectified dc signal, which is filtered and energizes either the positive or negative low-hysteresis switch. Energizing the switch provides the ground for the valve drivers. The minimum pulse generator will not allow the solenoid valves to turn off in less than 18 milliseconds, thus assuring a prescribed minimum thruster force. Minimum pulse generators are used in the pitch and roll channels only.

## Rate Signals (Figure 8-11)

Angular rate and rate command signals are provided by the logic functions of blocks Cp, Cy and Cr through the selection of modes M3, M5, M5D, and M6. Signal gains through the rate amplifiers are varied by the functions of logic blocks Ip, Iy, Ir, Pp, Py, and Pr, with the selection of the re-entry modes or platform mode. Rate signal inputs are used in the same manner as attitude signals to control solenoid valves. Roll rate signals are summed with the computer command signal and the proportional output is fed to the switch amplifiers. The function of the logic block M<sub>R</sub>, with selection of the re-entry modes of control, provides crosscoupling of roll rates into the yaw axis for re-entry control. Roll rate signals are proportionally coupled into yaw. This provides an opposite-phase signal for cancellation of part of the yaw rate command signal for proper stability.

## Horizon Sensor Signals

Sensor pitch and roll signals are positive or negative dc and are fed directly to out-of-phase choppers in ACE. A -5 degree pitch bias voltage is summed with the pitch horizon sensor output for pitch down orientation. The output of the



# PROJECT GEMINI



chopper will be of a phase opposite the attitude displacement (a positive attitude displacement will result in an out-of-phase output, and a negative attitude displacement will result in an in-phase output). This signal is then amplified and processed by the on-off logic in the same manner as an attitude signal.

The horizon scan mode, in addition to energizing circuits utilized by other modes, energizes the resistance - capacitance lag feedback networks and choppers for either the in-phase or out-of-phase signal. The lag network discharge rate, along with the minimum pulse generator operation, provides anti-hunting control (hunting would result from the slow response of the horizon sensors if no anti-hunt control were used).

## RCS Valve Drivers

The RCS solenoid valve drivers (Figure 8-13) are relays with normally-open contacts connected between the solenoid valve and the RCS ring switch. They provide a circuit ground when the switch is in the ACME position. The relays are energized by transistor relay drivers which conduct upon receiving thruster firing commands from the control torque logic switches or the attitude hand controller direct switches. Zener diode spike suppression is provided to limit the voltage generated when thruster power is interrupted.

## ORBIT ATTITUDE AND MANEUVER ELECTRONICS (OAME)

This unit (Figure 8-4) weighs approximately 8 pounds, has a removable cover and contains three removable module boards (2-relay boards and 1-component module board) as well as fixed components. The replaceable module boards, in conjunction with the fixed components, function as attitude valve drivers and provide spike suppression for the maneuver solenoid valves.



# PROJECT GEMINI

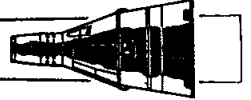

## Functional Operation

### Attitude Control

Attitude commands to the OAME are either positive or negative thruster firing logic commands to the solenoid valve drivers from the control torque logic section of ACE (Sec Figure 8-13). Upon receiving command signals, the valve driver transistors will conduct. This provides the circuit grounds to energize the solenoid valves of the propulsion system. Zener diode spike suppression is provided to limit the voltage generated when thruster power is interrupted.

### Maneuver Control

Maneuver commands originate from either of the two maneuver hand controllers (Figure 8-14). Translational command signals are obtained by applying a circuit ground through the proper hand controller switch to the solenoid valve for thruster firing. Conventional diode spike suppression is provided by the OAME package to limit the voltage spike generated when thruster power is interrupted.

### RATE GYRO PACKAGE (RGP)

The RGP (Figure 8-4) contains three rate gyros, each individually mounted and hermetically sealed. The gyros are orthogonally mounted for rate sensing in all three axes. The rate gyro package provides an analog outputs, proportional to attitude rate inputs. Application of a gimbal torquer current and monitoring of spin motor synchronization provide a check of gyro operation and pickoff output during ground checkout. Each gyro is separately excited so that any individual gyro may be turned on or off without affecting the operation of the other two. Two gyro packages are provided for redundancy and have a total weight of approximately 8 pounds.

# PROJECT GEMINI

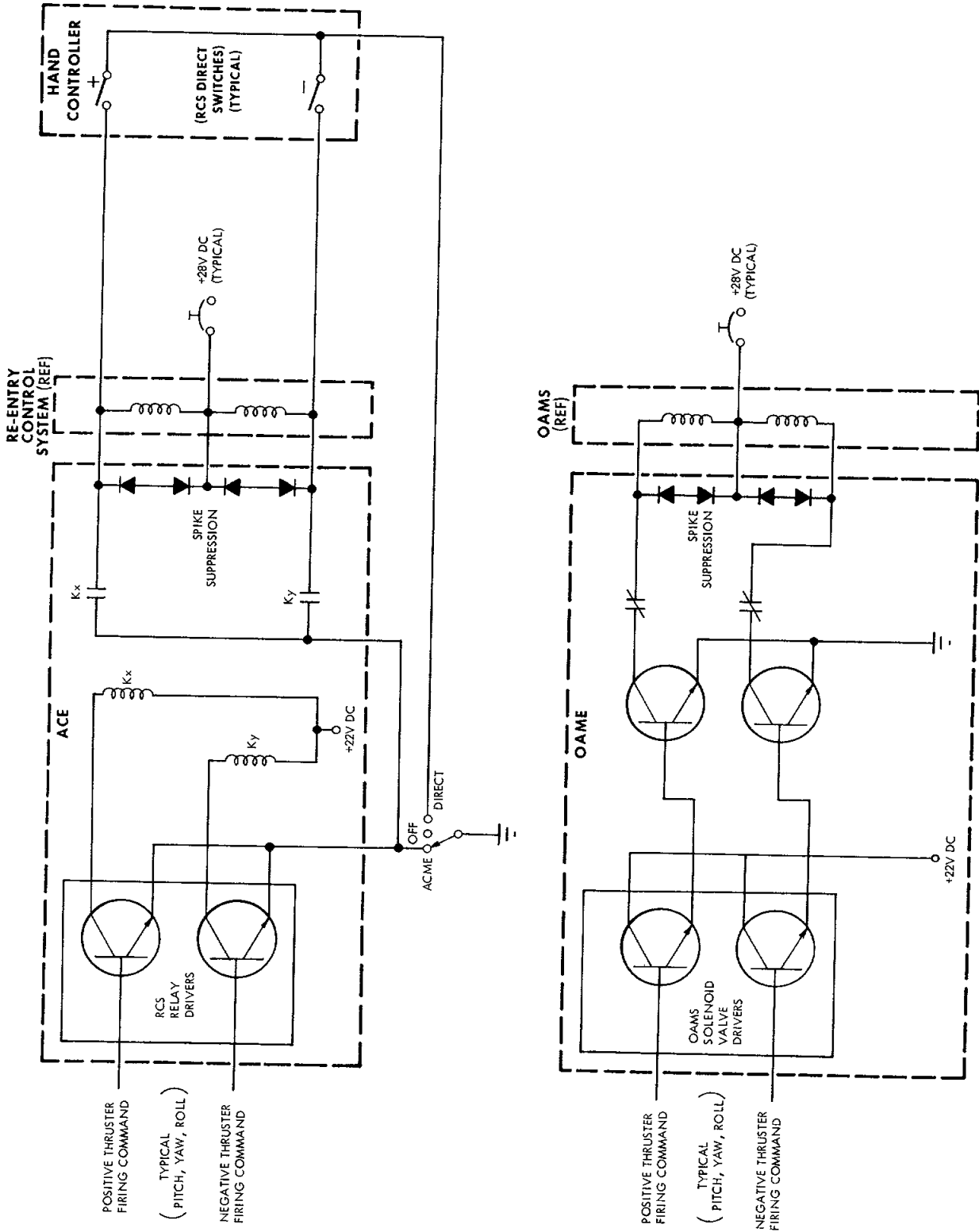

Figure 8-13 RCS & OAMS Attitude Valve Drivers

# PROJECT GEMINI

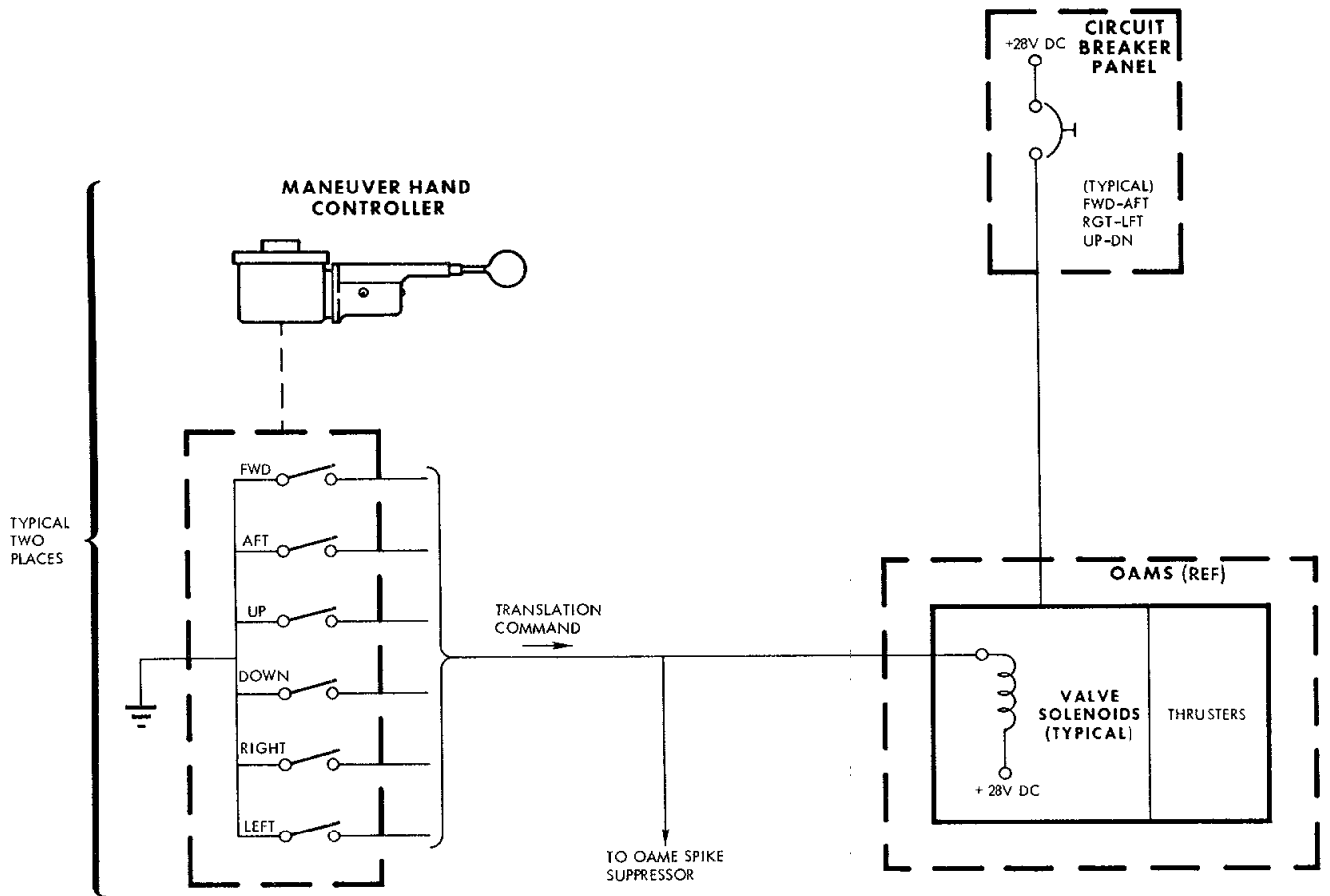
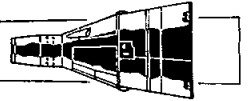

Figure 8-14 ACME Maneuver Control-Simplified Block Diagram



# PROJECT GEMINI



## POWER INVERTER PACKAGE

The power inverter (Figure 8-4) converts spacecraft dc power to ac power for use by the ACME subsystems and horizon sensors. The unit weighs approximately 7 pounds and consists of the following: current and voltage regulators, oscillator, power amplifier, output filter, regulator-controller, switching regulator and oscillator starter. The 26 vac, 400 cps power inverter output is supplied to the following:

- a. ACE power supply: reference power for the choppers, demodulators and dc biasing voltages.
- b. Rate gyros: 20 watts starting power and 16 watts running power for motor and pickoff excitation.
- c. Horizon sensors: 11 watts operational power, as reference for bias voltages and pickoff excitation.
- d. Attitude hand controller: 0.5 watts for potentiometer excitation.
- e. Telemetry: 1.0 watts for demodulation reference.
- f. FDI: 8.2 watts
- g. Rendezvous Radar: for angular reference.

# INERTIAL GUIDANCE SYSTEM

## TABLE OF CONTENTS

TITLE	PAGE
SYSTEM DESCRIPTION . . . . .	8-45
INERTIAL MEASUREMENT UNIT . . . . .	8-45
AUXILIARY COMPUTER POWER UNIT . . . . .	8-45
ON-BOARD COMPUTER . . . . .	8-46
SYSTEM OPERATION . . . . .	8-46
PRE-LAUNCH PHASE . . . . .	8-47
LAUNCH PHASE . . . . .	8-47
ORBIT PHASE . . . . .	8-48
RETROGRADE PHASE . . . . .	8-50
RE-ENTRY PHASE . . . . .	8-51
CONTROLS AND INDICATORS . . . . .	8-51
SYSTEM UNITS . . . . .	8-56
INERTIAL MEASUREMENT UNIT . . . . .	8-56
AUXILIARY COMPUTER POWER UNIT . . . . .	8-73
DIGITAL COMPUTER . . . . .	8-75
SYSTEM DESCRIPTION . . . . .	8-75
SYSTEM OPERATION . . . . .	8-79
MANUAL DATA INSERTION UNIT . . . . .	8-176
SYSTEM DESCRIPTION . . . . .	8-176
SYSTEM OPERATION . . . . .	8-179
AUXILIARY TAPE MEMORY . . . . .	8-185
SYSTEM DESCRIPTION . . . . .	8-185
SYSTEM OPERATION . . . . .	8-188
INCREMENTAL VELOCITY INDICATOR . . . . .	8-193
SYSTEM DESCRIPTION . . . . .	8-193
SYSTEM OPERATION . . . . .	8-195

# PROJECT GEMINI

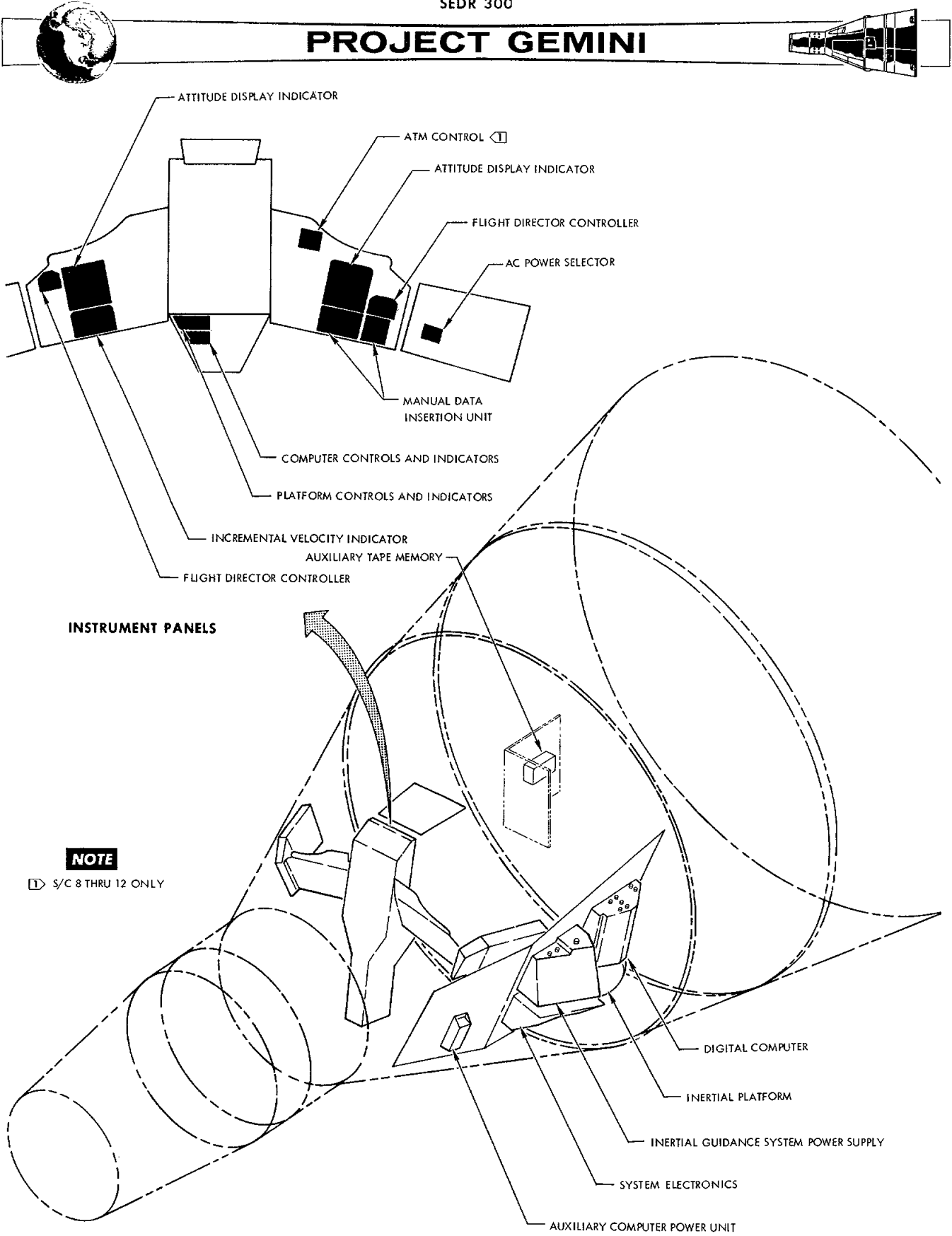

### INSTRUMENT PANELS

**NOTE**

1) S/C 8 THRU 12 ONLY

Figure 8-15 Inertial Guidance System



# PROJECT GEMINI



## INITIAL GUIDANCE SYSTEM

### SYSTEM DESCRIPTION

The Inertial Guidance System (IGS) consists of an Inertial Measurement Unit, an Auxiliary Computer Power Unit, an On-Board Computer, with Auxiliary Tape Memory and associated controls and indicators. The location of all IGS components is illustrated in Figure 8-15. Controls and indicators are located inside the pressurized cabin area. The Inertial Measurement Unit, Auxiliary Computer Power Unit, and the On-Board Computer are located in the unpressurized left equipment bay. The computer Auxiliary Tape Memory is mounted on the electronic module coldplate located in the adapter section (spacecraft 8 through 12).

### INERTIAL MEASUREMENT UNIT

The Inertial Measurement Unit (IMU) consists of three separate packages: the inertial platform, system electronics, and IGS power supply. All three packages function together to provide inertial attitude and acceleration information. Attitude measurements are utilized for automatic control, computations, and visual display. Acceleration measurements are utilized for insertion, rendezvous, and retrograde computations and displays. IMU operation is controlled by a mode selector. Cage, alignment, orbit rate, and inertial modes are available. Platform attitude measurements are available to each pilot on his attitude display group. The IMU is also capable of providing 400 cps power to ACME inverter loads. An AC POWER switch allows the pilot to select the source of 400 cps ACME power.

### AUXILIARY COMPUTER POWER UNIT

The Auxiliary Computer Power Unit (ACPU) provides protection for the computer,



# PROJECT GEMINI



from the spacecraft bus voltage variations. If bus voltage drops momentarily, the ACPU supplies temporary computer power. If bus voltage remains depressed, the computer is automatically turned off. The ACPU is activated by the computer power switch.

## ON-BOARD COMPUTER

The On-Board Computer (OBC) provides the necessary parameter storage and computation facilities for guidance and control. Computations are utilized for insertion, rendezvous, and re-entry guidance. A computer mode selector determines the type of computations to be performed. A START switch allows the pilot to initiate certain computations at his discretion. The COMP light indicates the start and completion of a computation. A MALF light indicates the operational status of the computer and a RESET switch provides the capability to reset the computer in case of temporary malfunctions. A Manual Data Insertion Unit (MDIU) allows the pilot to communicate directly with the computer. Specific parameters can be inserted, read out, or cleared from the computer memory. An Incremental Velocity Indicator (IVI) displays velocity changes. Changes can be measured or computed, depending on computer mode. An Auxiliary Tape Memory (ATM) that works in conjunction with the spacecraft computer is utilized in spacecraft 8 through 12. It provides greater memory capacity and allows in-flight loading of program modes in the computer.

## SYSTEM OPERATION

Operation of the IGS is dependent on mission phase. Components of IGS are utilized from pre-launch through re-entry phases. Landing phase is not controllable and therefore no IGS functions are required. The computer and platform each have mode selectors and can perform independent functions. However, when computations



# PROJECT GEMINI

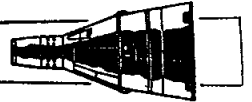

are to be made concerning inertial attitude or acceleration, the two units must be used together.

## PRE-LAUNCH PHASE

Pre-launch phase consists of the last 150 minutes before launch. This phase is utilized to warm-up, check-out, program, and align IGS equipment. After warm-up the computer performs a series of self checks to insure proper operation. Information not previously programmed but essential to the mission is now fed into the computer. AGE equipment utilizes accelerometer outputs to align IMU pitch and yaw gimbals with the local vertical. The roll gimbal is aligned to the desired launch azimuth by AGE equipment.

## LAUNCH PHASE

Launch phase starts at lift-off and lasts through insertion. During the first and second stage boost portion of launch, the guidance functions are performed by the booster autopilot. If the booster radio guidance system should fail, a Malfunction Detection System (MDS) provides automatic switchover to back-up (IGS) guidance. Back-up ascent guidance can also be selected manually at the discretion of the command pilot. The computer has been programmed with launch parameters and the IMU provides continuous inertial reference for back-up ascent guidance. To minimize launch errors, the computer is updated by ground stations throughout the launch phase. In the back-up ascent guidance operation, the computer provides steering and booster cut-off commands to the secondary booster autopilot. The computer also supplies attitude error signals to the flight director needles. The IMU provides inertial attitude reference to the attitude ball. At Second Stage Engine Cut-Off (SSECO) guidance control is switched from booster to Gemini IGS.



# PROJECT GEMINI

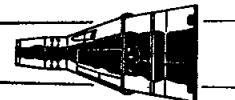

The computer starts insertion computations at SSECO and, at spacecraft separation, displays the incremental velocity change required for desired orbit insertion. When the required velocity change appears the command pilot will accelerate the spacecraft with the OAMS thrusters to insertion velocity. During acceleration the IMU supplies attitude and velocity changes to the computer. The computer continuously subtracts measured acceleration from required acceleration on the display. When insertion has been achieved the incremental velocity indication will be zero along all three axes.

## ORBIT PHASE

Orbit phase consists of that time between insertion and the start of retrograde sequence. If the IGS is not to be used for long periods of time it can be turned off to conserve power. If the platform has been turned off, it should be warmed up in the CAGE mode approximately one hour before critical alignment. The computer should be turned on in the PRE LN mode and allowed 20 seconds for self checks before changing modes. IGS operation during orbit is divided into three separate operations. The initial part of orbit is used for check out and alignment. The major part of orbit is used for rendezvous exercises and the final portion is used in preparation for retrograde and re-entry.

### Check-Out & Alignment

Immediately after orbit confirmation the spacecraft is maneuvered to small end forward and the platform aligned with the horizon sensors. Horizon sensor outputs are used to align pitch and roll gimbals in the platform. The yaw gimbal is



# PROJECT GEMINI

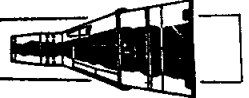

aligned through gyrocompassing techniques using the roll gyro output. This will align the yaw gyro to the orbit plane. Platform alignment will be maintained by the horizon sensors as long as SEF or BEF modes are used. ORB RATE mode is used when maneuvers are to be performed. ORB RATE is an inertially free mode except for the pitch gyro which is torqued at approximately four degrees per minute (orbit rate). The purpose of torquing the pitch gyro is to maintain a horizontal attitude with respect to the earth. If ORB RATE mode is used for long periods of time drift errors can occur. To eliminate errors due to gyro drift, the mode is switched back to SEF or BEF for alignment.

## Rendezvous Exercises

IGS operation during rendezvous exercises consists of performing inertial measurements and maneuver computations. Radar target information is provided to the computer for use in rendezvous computations. Platform alignment is performed in SEF or BEF mode prior to initiating a maneuver. The computer START button is pressed to initiate computation of velocity changes and computed velocity requirements are automatically displayed on the IVI. Flight director needles are referenced to the computer during rendezvous exercises and indicate the attitude in which translational thrust should be applied. When the spacecraft is in the correct attitude for a maneuver, all of the incremental velocity indication will be along the forward-aft translational axis. As thrust is applied, the IMU supplies the computer with attitude and acceleration information to continuously update the IVI indications. When the maneuver has been completed the platform can be realigned to the horizon sensors.



# PROJECT GEMINI

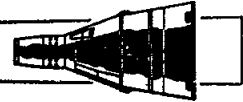

## Preparation for Retrograde & Re-Entry

Preparation for retrograde and re-entry is performed in the last hour before retrograde sequence. The AIM re-entry module IV is loaded into the computer (requires less than 40 minutes). If the IMU has been turned off, it must be turned on one hour before retrograde. (The gyros and accelerometers require approximately one half hour to warm up and another half hour is required for stabilization and alignment.) The attitude ball will indicate when platform gimbals are aligned to spacecraft axes. At this time the spacecraft is maneuvered to Blunt End Forward (BEF) and the platform aligned with the horizon sensors. The platform remains in BEF mode to maintain alignment until retrograde sequence. The computer retrograde initial conditions are checked and if necessary updated by either ground tracking stations or the pilot. Preparation for retrograde and re-entry is completed by placing the computer in RE-ENT mode.

## RETROGRADE PHASE

Retrograde phase starts 256 seconds prior to retrofire and ends approximately twenty-five seconds after retrofire initiation. At the start of retrograde phase a minus sixteen degree bias is placed on the pitch needle of the attitude indicator. At time-to-go-to retrograde minus 30 seconds ( $T_R-30$  seconds) the platform is placed in ORB RATE mode. While the retrorockets are firing (approximately 22 seconds) the acceleration and attitude are monitored by the IMU and supplied to the computer for use in re-entry computations. The computer starts computations for re-entry at retrofire. Computations are based on the time of retrofire, inertial position and attitude, and retrograde acceleration.



# PROJECT GEMINI

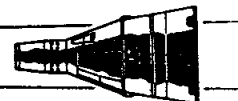

## RE-ENTRY PHASE

Re-entry phase starts immediately after the retrorockets stop firing and lasts until drogue chute deployment. After retrograde a  $180^\circ$  roll maneuver is performed and pitch attitude is adjusted so that the horizon can be used as a visual attitude reference. The spacecraft attitude is controlled by visual observation of the horizon until the computer commands a re-entry attitude at approximately 400,000 feet. The spacecraft is then controlled to null the flight director needles. Flight director needles are referenced to the computer during re-entry. The IMU supplies inertial attitude and acceleration signals to the computer. Bank angle commands are computed and displayed on the roll needle for down range and cross range error correction. The bank angle commands last between 0 to 500 seconds depending on the amount of down range and cross range error. Pitch and yaw needles display down range and cross range errors respectively. Upon completion of the bank angle commands (spacecraft on target) a roll rate of 15 degrees per second is commanded by the computer. At approximately 80,000 feet the computer commands an attitude suitable for drogue chute deployment. Immediately after drogue deployment the IGS equipment is turned off.

## CONTROLS AND INDICATORS

### Attitude Display Group

The Attitude Display Group (ADG), (Figure 8-16), consists of a Flight Director

# PROJECT GEMINI

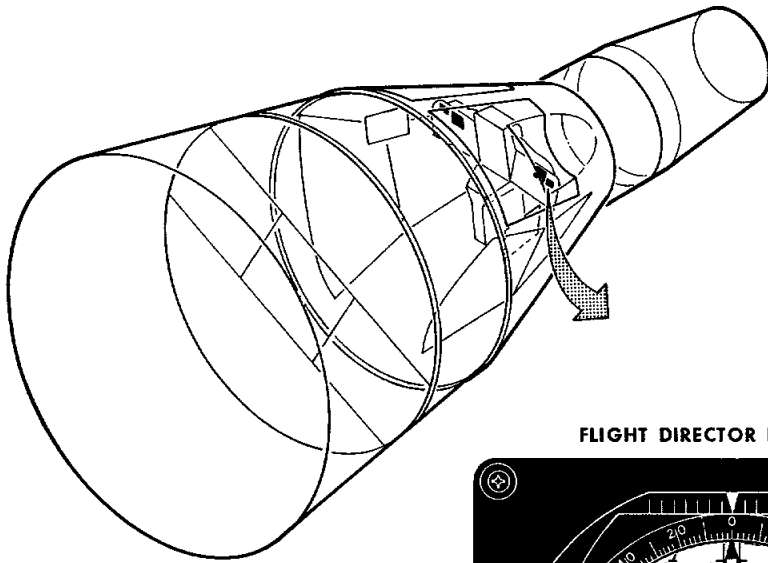
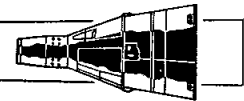

FLIGHT DIRECTOR INDICATOR

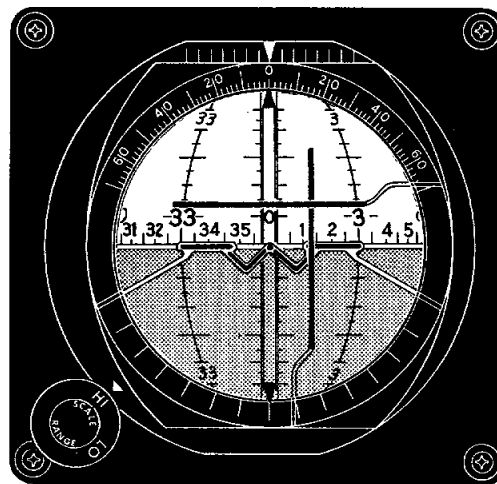

FLIGHT DIRECTOR CONTROLLER

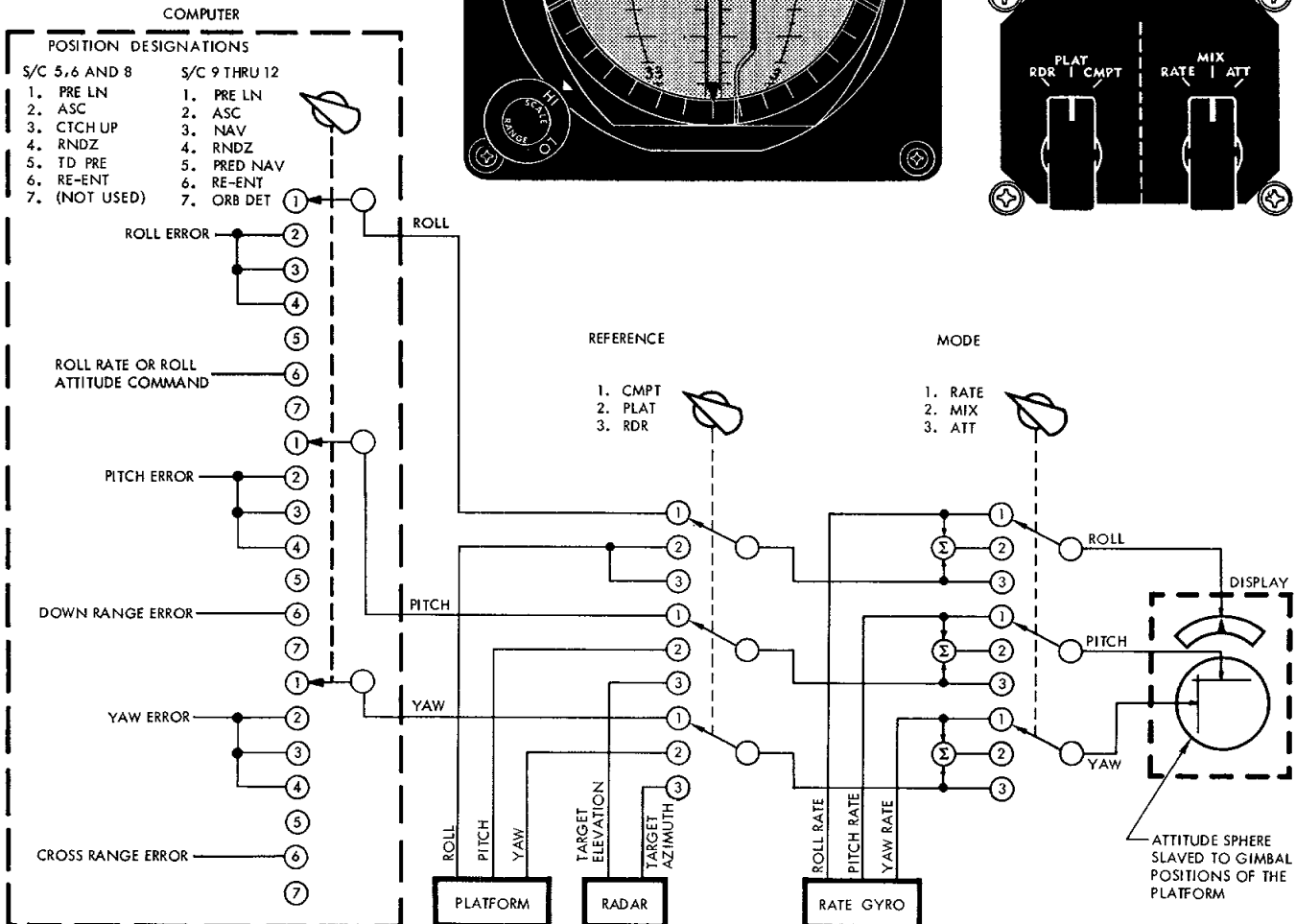
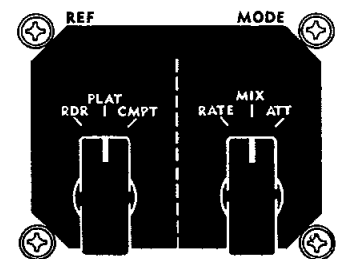

Figure 8-16 Attitude Display Group



# PROJECT GEMINI



Indicator (FDI) a Flight Director Controller (FDC) and their associated amplifiers. Three types of displays (attitude, attitude rate, and ADG power off) are provided by the FDI. A three axis sphere with 360 degrees of freedom in each axis continuously displays attitude information. The sphere is slaved to the inertial platform gimbals and always indicates platform attitude. Three needle type indicators display attitude and/or attitude rate information as selected by the pilot. Information displayed on the needles is provided by the computer, platform, radar, and rate gyros. A scale selector is included in the FDI to allow the selection of HI or LO scale indications on the needles. The FDC is used to select the source and type of display on the needles. Figure 8-16 includes a simplified schematic of the FDC switching and indicates the source and type of signal available. Since the computer is capable of producing different types of signals, the computer mode selector is included in the schematic. The FDC reference selector determines the source of display information. The FDC mode selector determines the type of signal displayed.

## Manual Data Insertion Unit

The Manual Data Insertion Unit (MDIU) consists of a ten digit keyboard and a seven digit register. The MDIU allows the pilot to communicate directly with the on-board computer. Provision is made to enter, cancel or read out information. The keyboard is used to address a specific location in the computer and set up coded messages for insertion. The first two keys that are pressed address the computer memory word location and the next five set up a coded message. Keys are pressed in a most significant bit first order. Negative



# PROJECT GEMINI

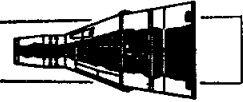

values are inserted by making the first number of the message a 9. The 9 then represents a minus sign and not a number. The seven digit register is used to monitor addresses and messages entered into or read out of the computer. Push button switches are included on the register panel to READ OUT, CLEAR, and ENTER the messages. The CLEAR switch does not clear the computer, it clears only the register. Information can also be inserted in the computer by the ground tracking stations which have Digital Command System capabilities.

## Incremental Velocity Indicator

The Incremental Velocity Indicator (IVI) provides a display of computed velocity increments required for, or resulting from a specific maneuver. The IVI is controlled through the on-board computer. Displays are utilized for orbit insertion, orbit correction, rendezvous maneuvers and retrograde. Velocity increments are provided along each of the spacecraft translational axis. Controls are included to manually insert plus or minus velocity increments into the IVI. The IVI also provides a display of tape position words and module words from the auxiliary tape memory.

## Computer Controls

Computer controls are located on the computer controls and indicators panel on the main instrument panel - center console (lower assy). See Figure 8-15. Computer controls consist of: a COMPUTER mode selector, a START switch, a COMP light, a MALF light, a RESET switch, and an ON-OFF switch. The COMPUTER mode selector is a seven position rotary switch which selects the type of computations to be performed. Modes of operation correspond to the mission phase in which they are utilized. The COMP light indicates when the computer is running through



# PROJECT GEMINI

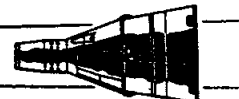

its program and provides a means of checking computer sequencing. The START switch is utilized for manual initiation of certain computations.

## **NOTE**

The START switch must be operated in conjunction with the COMPUTER mode selector and the COMP light.

The MALF light indicates when a malfunction has occurred and the RESET switch resets the computer malfunction indicator. The RESET switch is only capable of resetting the computer for momentary malfunctions. An ON-OFF switch controls power to the computer and the auxiliary computer power unit.

### IMU Controls & Indicators

The IMU controls and indicators consist of; a PLATFORM mode selector, an ACC light, an ATT light, a RESET switch, and an AC POWER selector. The PLATFORM mode selector is a seven position rotary switch which, in conjunction with the AC POWER selector, turns the platform on and off as well as control the mode of operation. Two cage modes, two align modes, one free mode, and an orbit rate mode of operation are selectable. The align modes are SEF and BEF. The ACC light indicates when a malfunction has occurred in the accelerometer portion of the IMU. The ATT light indicates when a malfunction has occurred in the attitude portion of the IMU. The RESET switch will turn off the lights, indicating that the IMU has returned to normal operation. The RESET switch works for momentary malfunctions of either type. Inability to reset the lights indicates a permanent malfunction. The AC POWER selector allows the pilot to turn the IGS inverter on without operating the platform or electronics circuits.



# PROJECT GEMINI



## SYSTEM UNITS

### INERTIAL MEASUREMENT UNIT

The Inertial Measurement Unit (IMU) is the inertial attitude and acceleration reference for the Gemini Spacecraft. The IMU consists of three separate packages; the inertial platform, platform electronics, and IGS power supply. All three packages conform to spacecraft contours for mounting convenience and have a total weight of 130 pounds. A functional block diagram (Figure 8-17) indicates functions and signal routing throughout all three packages. In addition to attitude and acceleration reference, the IMU provides ac and dc power for use in other units of guidance and control. The platform and electronics packages are mounted on cold plates to prevent overheating.

### **NOTE**

References to x, y, and z attitude and translational axes pertain to inertial guidance only and should not be confused with structural coordinate axes.

### Inertial Platform

The inertial platform (Figure 8-18) is a four gimbal assembly containing three miniature integrating gyros and three pendulous accelerometers. Gimbals allow the gyro mounting frame (pitch block) to remain in a fixed attitude while the housing moves freely about them. Major components of the platform are: a housing,



# PROJECT GEMINI

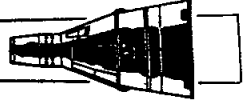

gimbal structure, torque motors, gimbal angle synchros, resolvers, gyros and accelerometers. The gimbals from inside to outside are: pitch, inner roll, yaw and outer roll. All gimbals, except inner roll, have 360 degrees of freedom. The inner roll gimbal is limited to plus and minus 15 degrees. Two roll gimbals are used to eliminate the possibility of gimbal lock. Gimbal lock can occur on a three gimbal structure when an attitude of 0 degrees yaw, 0 degrees pitch, and 90 degrees roll exists. At this time the roll and yaw gimbals are in the same plane and the yaw gimbal cannot move about its axis (gimbal lock). In the Gemini four gimbal platform an angle of 90 degrees is maintained between the inner roll and yaw gimbals thus preventing gimbal lock. The inertial components are mounted in the innermost gimbal casting (pitch block) for rigidity and shielding from thermal effects. The gyros and associated servo loops maintain the pitch block in a fixed relationship with the reference coordinate system. The accelerometer input axes are aligned with the three mutually perpendicular axes of the pitch block. Two sealed optical quality windows are provided in the housing for alignment and testing. Both windows provide optical access to an alignment cube located on the stable element.

## System Electronics

The system electronics package contains the circuitry necessary for operation of the IMU. Circuits are provided for gyro torque control, timing logic, spin motor power, accelerometer logic, accelerometer rebalance, and malfunction detection. Relays provide remote mode control of the above circuits.

# PROJECT GEMINI

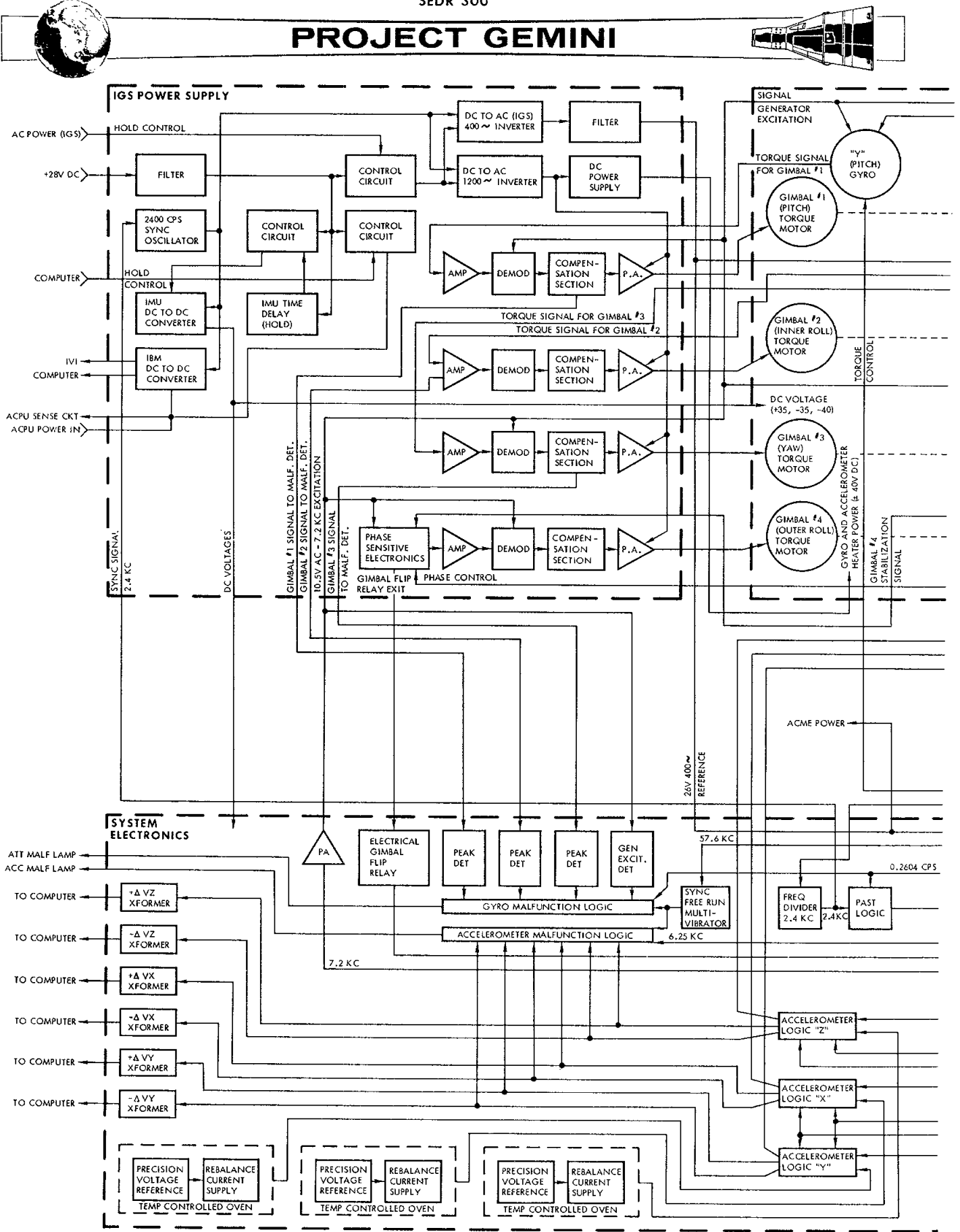

Figure 8-17 IMU Functional Block Diagram (Sheet 1 of 2)

# PROJECT GEMINI

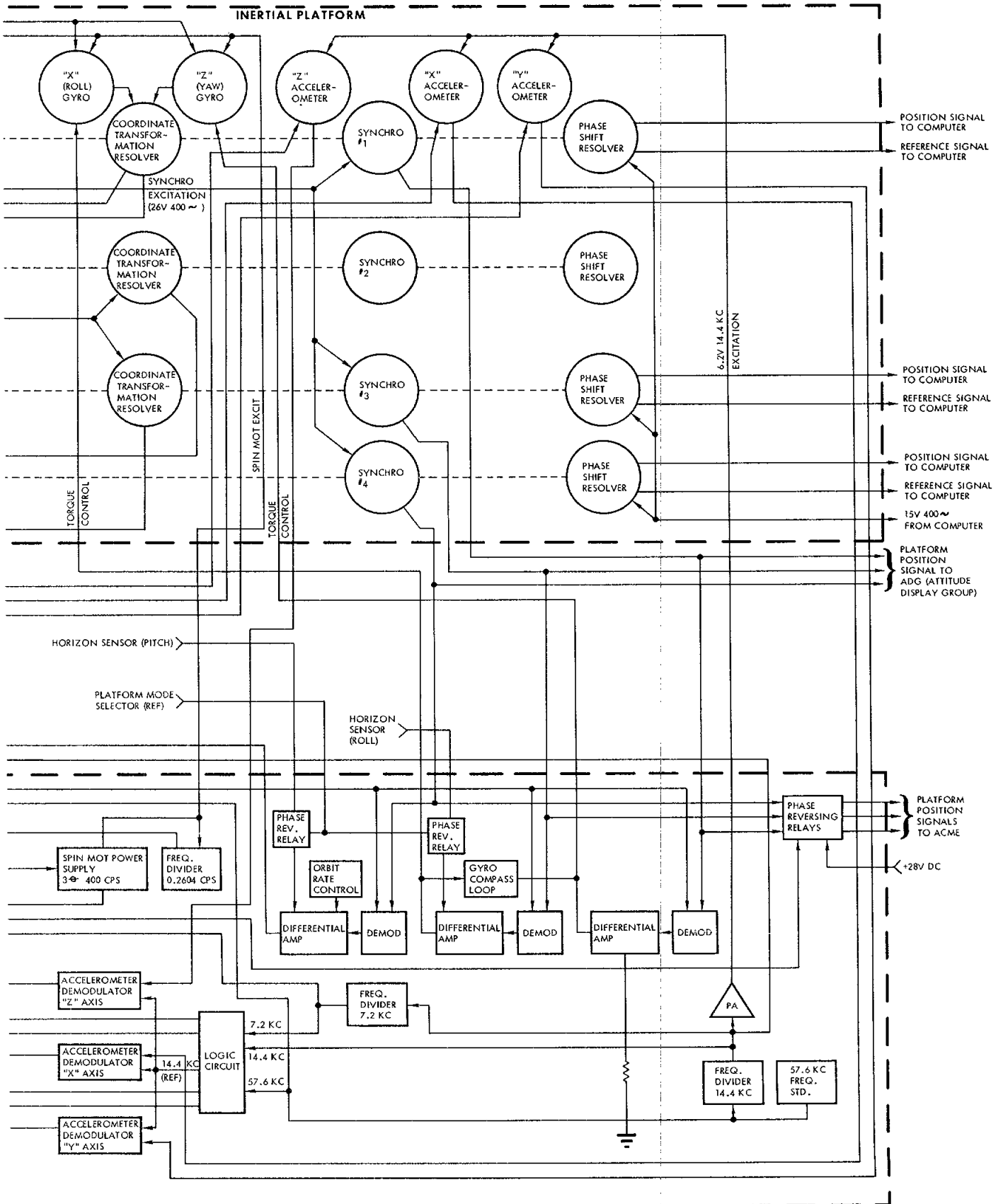
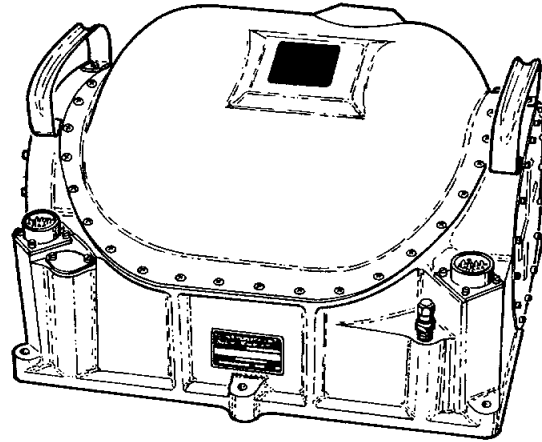
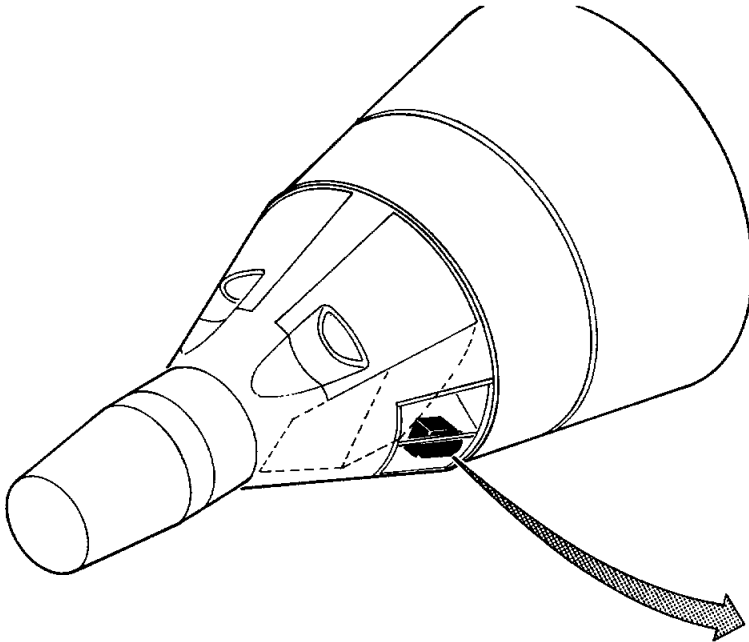
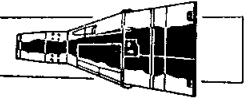

Figure 8-17 IMU Functional Block Diagram (Sheet 2 of 2)

# PROJECT GEMINI



**NOTE**

PLATFORM CO-ORDINATES -  $X_p, Y_p, Z_p$ .  
BODY CO-ORDINATES -  $X_b, Y_b, Z_b$ .

**INERTIAL PLATFORM**

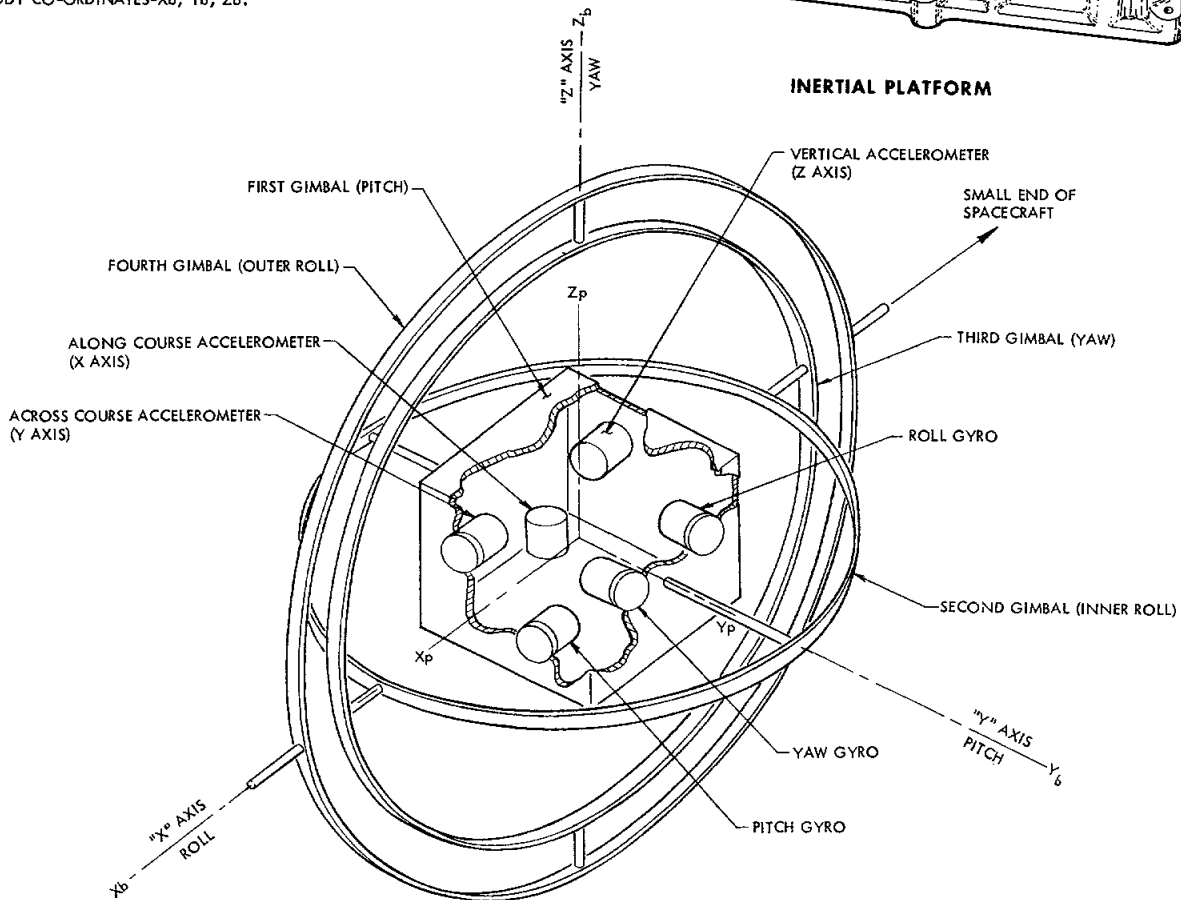
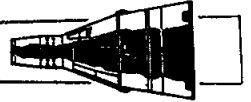

Figure 8-18 Inertial Platform Gimbal Structure



# PROJECT GEMINI



## IGS Power Supply

The IGS power supply (Figure 8-19) contains gimbal control electronics and the static power supply unit. Gimbal control electronics drive torque motors in the platform. Separate control circuits are provided for each gimbal. The static power supply provides the electrical power for the IMU, OBC, ACPU, MDIU, IVI, ACME, and horizon sensors. Figure 8-19 indicates the types of power available and the units to which they are supplied.

## Attitude Measurement

Attitude measurements are made from inertial platform gimbals and reflect the difference between spacecraft and gimbal attitudes. Platform gimbals are maintained in essentially a fixed inertial attitude by gimbal control electronics. As the spacecraft moves about the attitude axes, friction transfers some of the movement to platform gimbals. Three miniature gyros are used to sense minute gimbal attitude changes. When gyros sense a change in attitude, they produce a signal proportional to the attitude error. Gyro outputs are then used by gimbal control circuits to drive gimbals to their original inertial attitude. Gimbal positions relative to the spacecraft are measured by synchros and resolvers. Synchro outputs are provided for attitude display, automatic attitude control, and gyro alignment. Two types of resolvers, phase shift and coordinate transformation, are used. Phase shift resolvers provide gimbal angle information to the computer. Coordinate transformation resolvers provide attitude signal resolution for gimbal control purposes.

# PROJECT GEMINI

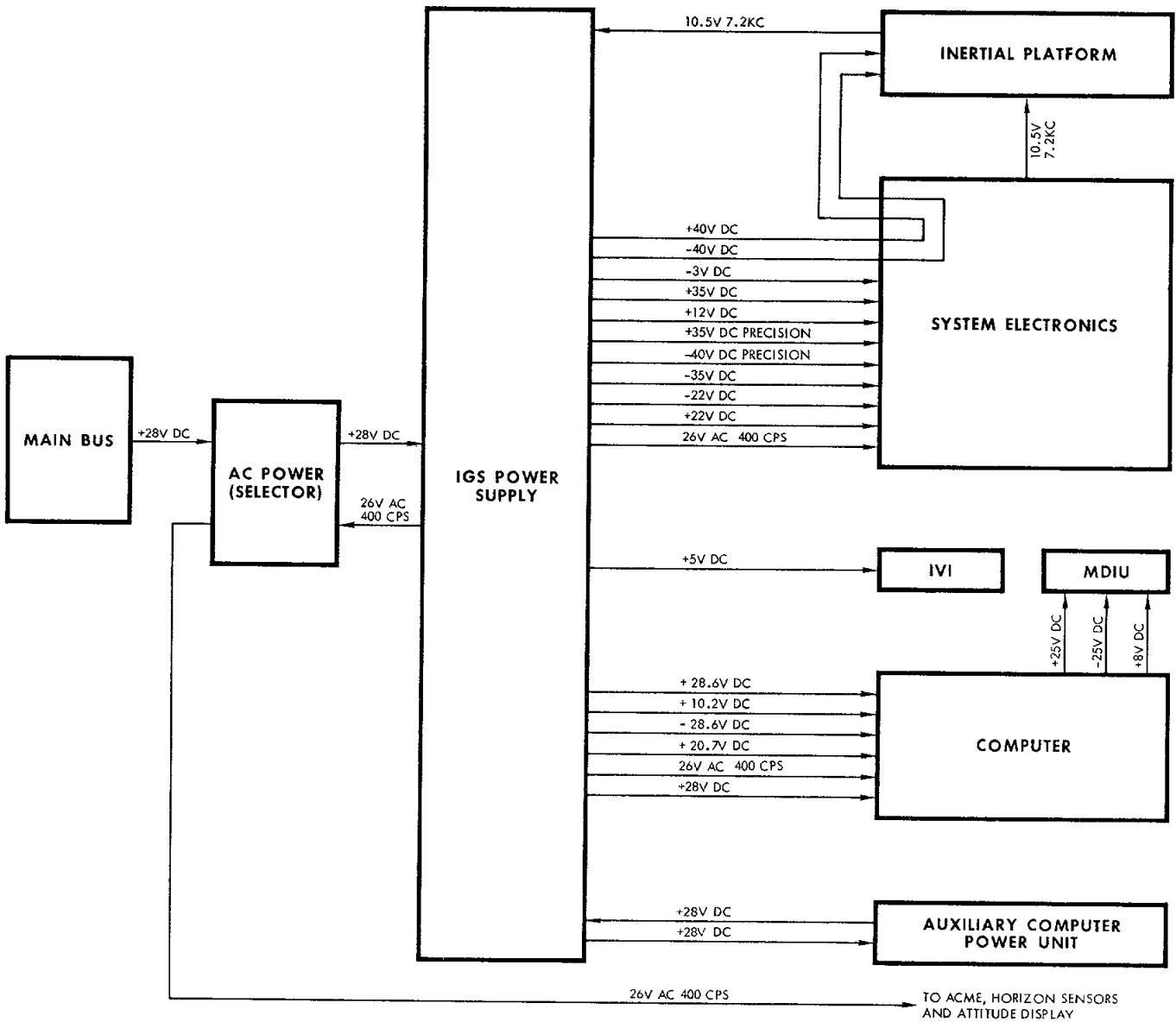
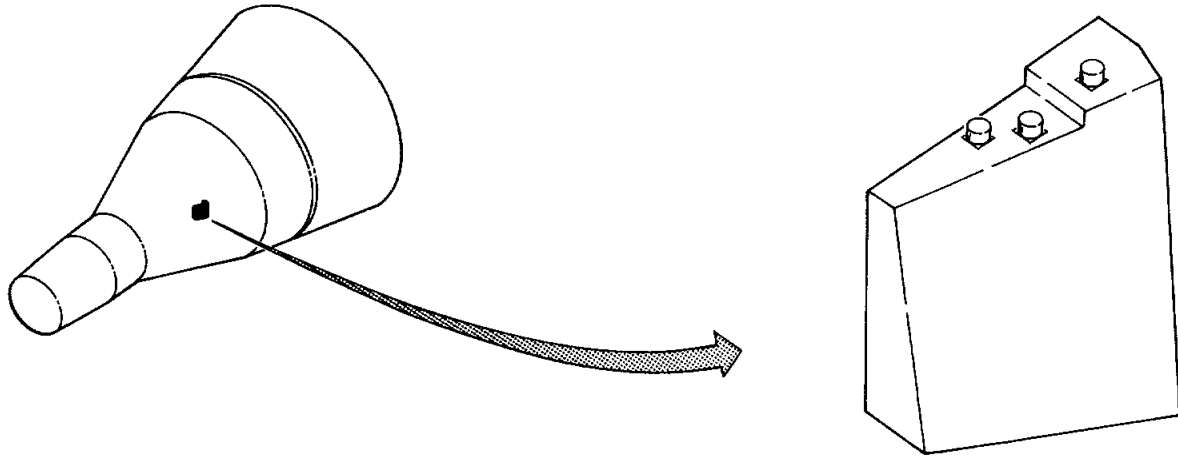
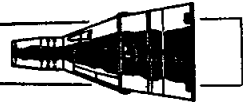

Figure 8-19 IGS Power Supply



# PROJECT GEMINI



## Modes of Operation

Seven modes of operation are selectable by the astronaut. The modes, in order of switch position are: OFF, CAGE, SEF, ORB RATE, BEF, CAGE, and FREE. The CAGE position is used for IMU warm-up and to align the platform gimbals with spacecraft body axes. Platform gimbals are caged prior to fine alignment with the horizon sensors. In the CAGE mode, gimbals are torqued by synchro outputs until a null is obtained on the synchro. When synchro outputs reach null, torquing stops and the gimbals are aligned with spacecraft axes. SEF (Small End Forward) mode is used to align the platform with the horizon sensors when the spacecraft is flying small end forward. Horizon sensor pitch and roll outputs are compared with synchro outputs and the difference used to torque gimbals. When synchro and horizon sensor outputs are balanced the gimbals are aligned to earth local vertical. A gyro compass loop aligns the yaw gimbal with the orbit plane.

### **NOTE**

If horizon sensors lose track during either SEF or BEF alignment modes, the platform is automatically switched to ORB RATE mode.

ORB RATE (orbit rate) mode is used to maintain attitude reference during spacecraft maneuvers. ORB RATE mode is inertially free except for the pitch gyro. The pitch gyro is torqued at approximately four degrees per minute to maintain a horizontal attitude with respect to the earth. If ORB RATE mode is used for long periods of time, drift can cause excessive errors in the platform. BEF (Blunt End Forward) mode is the same as SEF except that relays reverse the



# PROJECT GEMINI

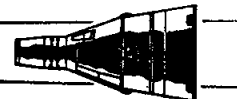

phase of horizon sensor inputs. The second CAGE mode allows the platform to be caged in blunt end forward without switching back through other modes. FREE mode is used during launch and re-entry phases. FREE mode is completely inertial and the only torquing employed is for drift compensation.

## **NOTE**

FREE mode is selected automatically by the Sequential System at retrofire.

### Gimbal Control Circuits

Four separate servo loops provide gimbal attitude control. Figure 8-17 illustrates the signal flow through all four loops. Gyro signal generator outputs are used either directly or through resolvers as the reference for gimbal control. Both phase and amplitude of signal generator outputs are functions of gimbal attitude. Gimbal number one (pitch) is controlled directly by the pitch gyro output. Error signals produced by the pitch gyro are amplified, demodulated, and compensated, then used to drive the pitch gimbal torque motor. The first amplifier raises the signal to the level suitable for demodulation. After amplification, the signal is demodulated to remove the 7.2 KC carrier. A compensation section keeps the signal within the rate characteristics necessary for loop stability. When the signal is properly conditioned by the compensation section, it goes to a power amplifier. The power amplifier supplies the current required to drive the gimbal torque motor. The torque motor then drives the gimbal maintaining gyro outputs at or very near null.



# PROJECT GEMINI

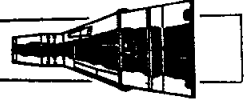

Roll and yaw servo loops utilize resolvers to correlate gimbal angles with gyro outputs. Inner roll and yaw gimbals are controlled by a coordinate transformation resolver mounted on the pitch gimbal. When the spacecraft is at any pitch attitude other than 0 or 180 degrees, some roll motion is sensed by the yaw gyro and some yaw motion is sensed by the roll gyro. The amount of roll motion sensed by the yaw gyro is proportional to the pitch gimbal angle. The resolver mounted on the pitch gimbal angle. Resolver output is then conditioned in the same manner as in the pitch servo loop to drive inner roll and yaw gimbals.

The outer roll gimbal is servo driven from the inner roll gimbal resolver. A coordinate transformation resolver mounted on the inner roll gimbal, monitors the angle between inner roll and yaw gimbals. If the angle is anything other than 90 degrees an error signal is produced by the resolver. The error signal is conditioned in the same manner as in the pitch servo loop to drive the outer roll gimbal. One additional circuit (phase sensitive electronics) is included in the outer roll servo loop. The outer roll gimbal torque motor is mounted on the platform housing and moves about the stable element with the spacecraft. As the spacecraft moves through 90 degrees in yaw, the direction that the outer roll gimbal torque motor must rotate to compensate for spacecraft roll, reverses. Phase sensitive electronics and a resolver provide the phase reversal necessary for control. The resolver is used to measure rotation of the yaw gimbal about the yaw axis. As the gimbal rotates through 90 degrees in yaw, the resolver



# PROJECT GEMINI



output changes phase. Resolver output is compared to a reference phase by the phase sensitive electronics. When the resolver output changes phase, the torque motor drive signal is reversed.

## Pre-Launch Alignment

The IMU is the inertial reference for back-up ascent guidance and must therefore be aligned for that purpose. The platform is aligned to local vertical and the launch azimuth. Platform X and Y accelerometers are the reference for local vertical alignment. When the platform is aligned to the local vertical, X and Y accelerometers are level and cannot sense any acceleration due to gravity. If any acceleration is sensed, the platform is not properly aligned and must be torqued until no error signal exists. The accelerometer output is used by AGE equipment to generate torque signals for the gyros. When the gyro is torqued it produces an error signal which is used to align the gimbal. The outer roll gimbal synchro output is compared with a signal representing the launch azimuth by AGE equipment. The error signal is conditioned by AGE equipment and applied to the yaw gyro torque generator. The yaw gyro signal generator then produces a signal proportional to the input torque. Gyro output is coordinated by a resolver mounted on the pitch gimbal. Since the spacecraft is in a 90 degree pitch up attitude essentially all of the yaw gyro output is transferred to roll gimbal control electronics. The electronics drive the roll gimbals until no error exists between synchro output and the AGE reference signal. When no error signal exists, the platform is aligned to the launch azimuth.



# PROJECT GEMINI



## Orbit Alignment

Alignment of the platform in orbit is accomplished by referencing it to the horizon sensors. Placing the platform mode selector in SEF or BEF position will reference it to the horizon sensors. Pitch and roll horizon sensor outputs are compared with platform pitch and outer roll synchro outputs. Differential amplifiers produce torque control signals proportional to the difference between sensor and synchro outputs. Torque control signals are used to drive pitch and roll gyro torque generators. Gyro signal generator outputs are then used by gimbal control electronics to drive platform gimbals. When synchro and horizon sensor outputs balance, the pitch and roll gimbals are aligned to the local vertical. The yaw gimbal is aligned to the orbit plane through a gyro compass loop. If yaw errors exist, the roll gyro will sense a component of orbit rate. The roll gyro output is used through a gyro compass loop to torque the yaw gyro. Yaw gyro output is then used by gimbal control electronics to drive the yaw gimbal. When the roll gyro no longer senses a component of orbit rate, the yaw gimbal is aligned to the orbit plane. All three gimbals are now aligned and will remain aligned as long as SEF or BEF modes are used. The pitch gyro will be continuously torqued (at the orbit rate) to maintain a horizontal attitude.

### **NOTE**

If horizon sensors lose track while the platform is in SEF or BEF modes, the platform is automatically switched to ORB RATE mode.



# PROJECT GEMINI

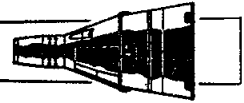

## Orbit Rate Circuit

The orbit rate circuit is used to maintain alignment to the local vertical during orbit maneuvers. Local vertical cannot be provided by horizon sensors during maneuvers because they will lose track. To maintain a horizontal attitude with no external reference, the pitch gyro is torqued at approximately four degrees per minute. The torque represents the spacecraft orbit rate. Torque is obtained by placing a DC bias on the output of the pitch differential amplifier. The bias drives the pitch gyro torquer at approximately the orbit rate. Orbit rate bias is adjustable and can be set to match orbits of various altitudes.

## Phase Angle Shift Technique

Phase Angle Shift Technique (PAST) is a method of improving gyro drift repeatability. One of the factors which affects gyro drift is spin motor rotor unbalance. The effect of unbalance will vary with changes in the point of lock on with the synchronous motor's rotating field. The spin motor can lock on to a different point each time it is started. Drift errors due to rotor unbalance are in the order of 0.5 degrees per hour. PAST provides a means of reducing drift errors by a factor of ten. To cancel drift errors, PAST shifts the phase of spin motor excitation 30 degrees at regular intervals. Shifting the phase causes the rotor to lock on a different point each time the phase is shifted. Drifts now tend to cancel and become predictable. (When drift is predictable it can be compensated for.) All three gyro torque control loops contain drift compensation circuits. The drift compensation circuits apply a dc bias to each gyro torque generator. Drift compensation torques the gyro in the opposite



# PROJECT GEMINI



direction as predictable drift, maintaining a stable attitude.

## Attitude Malfunction Detection

An attitude malfunction detection circuit performs self checks of gyro signal generator excitation, gimbal control signals, logic timing signals, and critical voltages. Gyro signal generator excitation is checked for presence and proper amplitude. Gimbal control signals are checked for the length of time signals are present. The logic timing signal (28.8kc) is checked for presence. Critical voltages (+22vdc, -3vdc, +12vdc) are checked for presence. If a malfunction is detected, an ATT light on the control panel is automatically illuminated. If momentary malfunctions occur, the ATT indicator can be restored to normal operation by pressing the RESET button.

### **NOTE**

If the attitude measurement circuits malfunction, the acceleration indications are not reliable. Accelerometer axes will not be properly aligned and indications are along unknown axes.

## Acceleration Measurement

Acceleration is measured along three mutually perpendicular axes of the inertial platform. Sensing devices are three miniature pendulous accelerometers. The



# PROJECT GEMINI



accelerometers are mounted in the platform pitch block and measure acceleration along gyro x, y, and z axes. Accelerometer signal generators produce signals whose phase is a function of the direction of acceleration. Signal generator output is used to control torque rebalance pulses. The torque rebalance pulses drive accelerometer pendulums toward their null position. Rebalance pulses are dc current whose polarity is controlled by signal generator output. The polarity of rebalance pulses indicates the direction of acceleration and the algebraic sum of the pulses indicates the amount of acceleration. Rebalance pulses are supplied to the spacecraft digital computer where they are used for computations and incremental velocity displays.

## Torque Rebalance Loop

Three electrically identical torque rebalance loops are used to control accelerometer pendulum positions. Normally an analog loop would be used for this purpose; however, if an analog loop were used, the output would have to be converted to digital form for use in the computer. To eliminate the need for an analog to digital converter, a pulse rebalance loop is used. Short duration 184 milliampere dc current pulses drive the accelerometer pendulum in one direction until it passes through null. Pulses are applied at the rate of 3.6kc. When the pendulum passes through null, signal generator output changes phase. The signal generator output is demodulated to determine the direction of the pendulum from null. Demodulator output is used by logic circuits to control the polarity of rebalance pulses. If acceleration is being sensed, there will be more pulses of one polarity than the other. If no acceleration is being sensed, the number of pulses of



# PROJECT GEMINI



each polarity will be equal. In addition to controlling the polarity of rebalance pulses, logic circuits set up precision timing of the pulses. Precision frequency inputs from the timing circuits are the basis for rebalance pulse timing. Precise timing is essential because the amount of pendulum torque depends on the length of the current pulse. All pulses are precisely the same duration and amplitude, therefore total torque is dependent only on the algebraic sum of the applied pulses. Each time a rebalance pulse is applied to the accelerometer torquer, a pulse is also provided to the computer. Algebraic summation of the rebalance pulses is performed by the computer.

## Pulse Rebalance Current Supply

A pulse rebalance current supply provides the required current for torque rebalance. Since acceleration measurements are based on the number of torque pulses it is essential that all pulses be as near identical as possible. To maintain a stable current, a negative feedback circuit is employed. The supply output is passed through a precision resistor and the voltage drop across the resistor compared to a precision voltage reference. Errors detected by the comparison are used in the feedback circuit to correct any deviations in current. To further enhance stability both the current supply and the precision voltage reference are housed in a temperature controlled oven.

## Accelerometer Dither

A pendulous accelerometer, unlike a gyro, has an inherent mass unbalance. The mass unbalance is necessary to obtain the pendulum action. Due to the unbalance, perfect flotation of the pendulous gimbal cannot be achieved and consequently



# PROJECT GEMINI



pressure is present on the gimbal bearing. To minimize the stiction effect, caused by bearing friction, a low amplitude oscillation is imposed on the gimbal. The oscillation (dither) prevents the gimbal from resting on its bearing long enough to cause stiction. To obtain gimbal oscillation, two signals are required: a 100 cps dither signal and a dc field current. The dc field current is superimposed on the signal generator excitation and creates a magnetic field around the gimbal. The 100 cps dither is applied to a separate (modulator) coil. The dither signal beats against the dc field, causing the gimbal to oscillate up and down. The dither motion is not around the output axis and consequently no motion is sensed by the signal generator.

## Accelerometer Malfunction Detection

An acceleration malfunction detection circuit performs self checks of incremental velocity pulses and critical voltage. Incremental velocity pulses from each of the three axes are checked for presence. If pulses are absent longer than 0.35 seconds, it indicates that a flip flop did not reset between set pulses. The critical voltage (+12 vdc) is checked for presence. If a malfunction is detected, an ACC light on the control panel is automatically illuminated. If momentary malfunctions occur, the accelerometer malfunction circuit can be restored to normal operation by pressing the RESET button.

## **NOTE**

Malfunction of the accelerometer circuits  
does not affect attitude measurements.



# PROJECT GEMINI



## AUXILIARY COMPUTER POWER UNIT

The Auxiliary Computer Power Unit (ACPU) is used in conjunction with the IGS power supply to maintain the correct dc voltages at the computer. The computer cannot function properly on low voltage either as a transient or a depression. Abnormal voltages can cause permanent changes in the computer memory. Three types of circuits are provided in the ACPU to prevent a low voltage condition at the computer. The first circuit is a transient sense and auxiliary power control circuit. The second circuit is a low voltage sense and power control circuit and the third is auxiliary power. The ACPU is turned on and off with the COMPUTER ON-OFF switch.

### Transient Sense Circuit

The transient sense circuit is designed to sense and correct transient low voltage conditions. A series type transistor voltage regulator holds auxiliary power off the line as long as IGS power supply computer voltage regulator voltage is normal. If regulator voltage momentarily drops below a minimum of 17.5 volts, the transient sense circuit detects the drop and turns on the series regulator. The regulator then places auxiliary power on the line and maintains voltage at the desired level.

### Low Voltage Sense Circuit

A low voltage sense circuit prevents the computer from operating on low voltage. When the computer is turned on, the low voltage sense circuit insures that spacecraft bus voltage is above 21 volts before allowing power to be applied to the



# PROJECT GEMINI



computer. If the computer is already on when a low voltage condition occurs, the transient sense circuit will maintain normal voltage for 100 milliseconds. If spacecraft bus voltage is not back to normal after 100 milliseconds the low voltage sense circuit initiates a controlled shutdown of the computer. Computer power is controlled through contacts of a relay in the low voltage sense circuit. When the low voltage sense circuit detects a voltage depression it deenergizes the relay. Contacts of the relay initiate a computer shutdown in a manner identical with the computer power switch. When the low voltage sense circuit turns off the computer it also breaks power to all ACPU circuits except low voltage sense. If power were not broken to the transient sense circuit it would attempt to maintain normal voltage at the computer. In attempting to maintain normal voltage the auxiliary power capability would be exceeded.

## Auxiliary Power

Auxiliary power consists of a battery and a trickle charger. A 0.5 ampere-hour nickel cadmium battery is used to supply computer power during spacecraft bus low voltage transients. The battery will supply up to 9.8 amperes for periods of 100 milliseconds or less. A trickle charger is provided to maintain a full charge on the battery. The charger consists of a transistor oscillator, transformer, and rectifier. The oscillator changes static power supply dc voltage to ac. The ac voltage is then stepped up with a transformer and changed back to dc by a full wave diode rectifier. Rectifier output is then applied, through a current limiting resistor, to the battery. The resistor limits charging current to 25 milliamperes. Provision is included to charge the battery from an external source if desired.



# PROJECT GEMINI



## DIGITAL COMPUTER

### SYSTEM DESCRIPTION

#### General

The Digital Computer, hereinafter referred to as the computer, is a binary, fixed-point, stored-program, general-purpose computer, used to perform on-board computations. The computer is 18.90 inches high, 14.50 inches wide, and 12.75 inches deep. It weighs 58.98 pounds. External views of the computer are shown in Figure 8-20. The major external characteristics are summarized in the accompanying legend.

Using inputs from other spacecraft systems, along with a stored program, the computer performs the computations required during the pre-launch, insertion, catch-up, rendezvous, and re-entry phases of the mission. In addition, the computer provides back-up guidance for the launch vehicle during ascent.

#### Inputs and Outputs

The computer is interfaced with the Inertial Platform, System Electronics, Inertial Guidance System Power Supply, Auxiliary Computer Power Unit, Manual Data Insertion Unit, Time Reference System, Digital Command System, Attitude Display, Attitude Control and Maneuver Electronics, Titan Autopilot, Auxiliary Tape Memory (spacecraft 8 through 12), Pilots' Control and Display Panel, Incremental Velocity Indicator, Instrumentation System, and Aerospace Ground Equipment. In connection with these interfaces, the computer inputs and outputs include the following:

##### Inputs

40 discrete

3 incremental velocity

PROJECT GEMINI

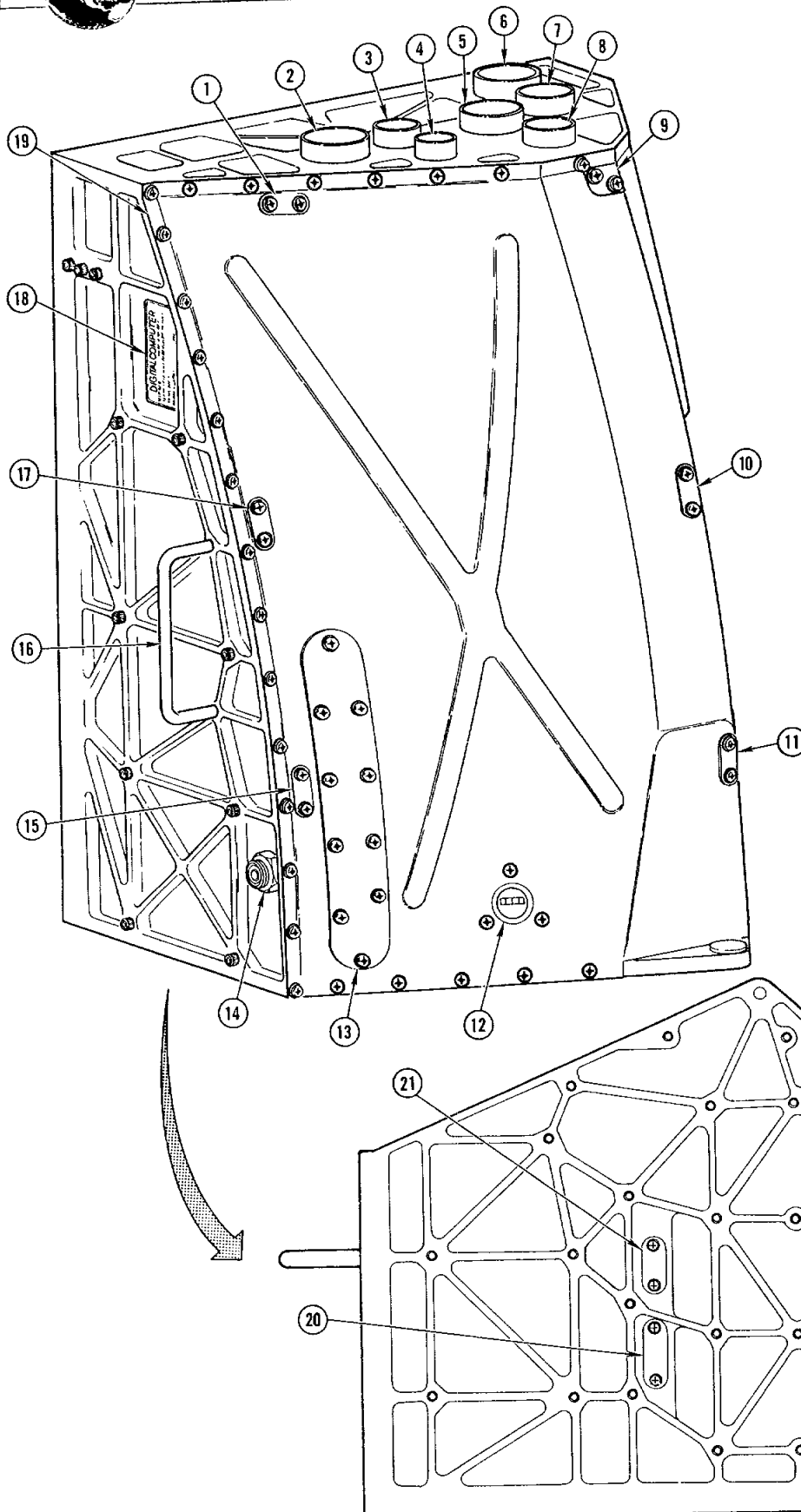
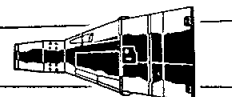

LEGEND	
ITEM	NOMENCLATURE
1	MOUNTING ACCESS COVER
2	CONNECTOR J4
3	CONNECTOR J5
4	CONNECTOR J7
5	CONNECTOR J3
6	CONNECTOR J2
7	CONNECTOR J1
8	CONNECTOR J6
9	MOUNTING ACCESS COVER
10	MOUNTING ACCESS COVER
11	MOUNTING ACCESS COVER
12	ELAPSED TIME INDICATOR
13	CONNECTOR ACCESS COVER
14	RELIEF VALVE
15	MOUNTING ACCESS COVER
16	HANDLE
17	MOUNTING ACCESS COVER
18	IDENTIFICATION PLATE
19	MAIN ACCESS COVER
20	BUS BAR ACCESS COVER
21	BUS BAR ACCESS COVER
22	RELIEF VALVE

Figure 8-20 Digital Computer



# PROJECT GEMINI



## Inputs (cont)

- 3 gimbals angle
- 2 high-speed data (500 kc)
- 1 low-speed data (3.57 kc)
- 1 low-speed data (182 cps)
- 1 input and read-back (99 words)
- 6 dc power (5 regulated, 1 unregulated)
- 1 ac power (regulated)

## Outputs

- 30 discrete
- 3 steering command
- 3 incremental velocity
- 1 decimal display (7 digits)
- 1 telemetry (21 digital data words)
- 1 low-speed data (3.57 kc)
- 1 low-speed data (182 cps)
- 3 dc power (regulated)
- 1 ac power (regulated, filtered)

## Operational Characteristics

The major operational characteristics of the computer are as follows:

### Type

Binary, fixed-point, stored-program, general-purpose



# PROJECT GEMINI



## Memory

Random-access, nondestructive-readout

Flexible division between instruction and data storage

4096 addresses, 39 bits per address

13 bits per instruction word

26 bits per data word

## Arithmetic Times

Instruction cycle - 140 usec

Divide requires 6 cycles

Multiply requires 3 cycles

All other instruction require 1 cycle each

Other instructions can be programmed concurrently with multiply and divide

## Clock Rates

Arithmetic bit rate - 500 kc

Memory cycle rate - 250 kc

## Controls and Indicators

The computer itself contains no controls and indicators, with the exception of the elapsed time indicator. However, the computer can be controlled by means of four switches located on the Pilots' Control and Display Panel: a two-position ON-OFF switch, a seven-position mode switch, a push-button START Computation switch, and a push-button RESET switch.



# PROJECT GEMINI

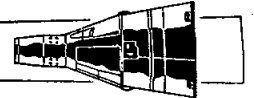

## SYSTEM OPERATION

### Power

The computer receives the ac and dc power required for its operation from the Inertial Guidance System (IGS) Power Supply. The regulated dc power supplied to the computer is buffered in the IGS Power Supply in a manner that eliminates any loss in regulation due to transients that occur in the spacecraft prime power source. Actual power interruptions and depressions are buffered by the IGS Power Supply and the Auxiliary Computer Power Unit. The power inputs received from the IGS Power Supply are as follows:

- (a) 26 vac and return
- (b) +28 vdc filtered and return
- (c) +27.2 vdc and return
- (d) -27.2 vdc and return
- (e) +20 vdc and return
- (f) +9.3 vdc and return

The application of all power is controlled by the ON-OFF switch on the Pilots' Control and Display Panel. When the switch is turned on, the computer elapsed time indicator starts operating and a power control signal is supplied to the IGS Power Supply by the computer. This signal causes power to be transferred to the computer. When the switch is turned off, the computer elapsed time indicator stops operating and the power control signal is terminated to remove power from the computer.



# PROJECT GEMINI

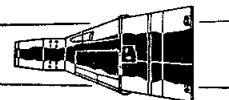

Within the computer, the 26 vac power is used by magnetic modulators to convert dc analog signals to ac analog signals. This power is also used by a harmonic filter to develop a 16 vac, 400 cps filtered gimbal angle resolver excitation signal. The +28 vdc power is used by computer power sequencing circuits. The +27.2 vdc, -27.2 vdc, +20 vdc, and +9.3 vdc power is used by power regulators to develop +25 vdc, - 25 vdc, and +8 vdc regulated power. This regulated power is used by logic circuits throughout the computer, and is supplied to some of the other spacecraft systems.

## Basic Timing

The basic computer timing is derived from an 8 mc oscillator. The 8 mc signal is counted down to generate four clock pulses (called W, X, Y, and Z) (Figure 8-21). These clock pulses are the basic timing pulses from which all other timing is generated. The width of each clock pulse is 0.375 usec and the pulse repetition frequency is 500 kc. The bit time is 2 usec, and a new bit time is considered as starting each time the W clock pulse starts. Eight gate signals (G1, G3, G5, G7, G9, G11, G13, and G14) are generated, each lasting two bit times. The first and second bit times of a particular gate are discriminated by use of a control signal (called IA) which is on for odd bit times and off for even bit times. Fourteen bit times make up one phase time, resulting in a phase time length of 28 usec (Figure 8-22). Five phases (PA through PE) are required to complete a computer instruction cycle, resulting in an instruction cycle length of 140 usec. Special phase timing, consisting of four phases (PH1 through PH4) (Figure 8-23), is generated for use by the input processor and the output processor. This timing is independent of computer phase timing but is synchronized with computer bit timing.



# PROJECT GEMINI

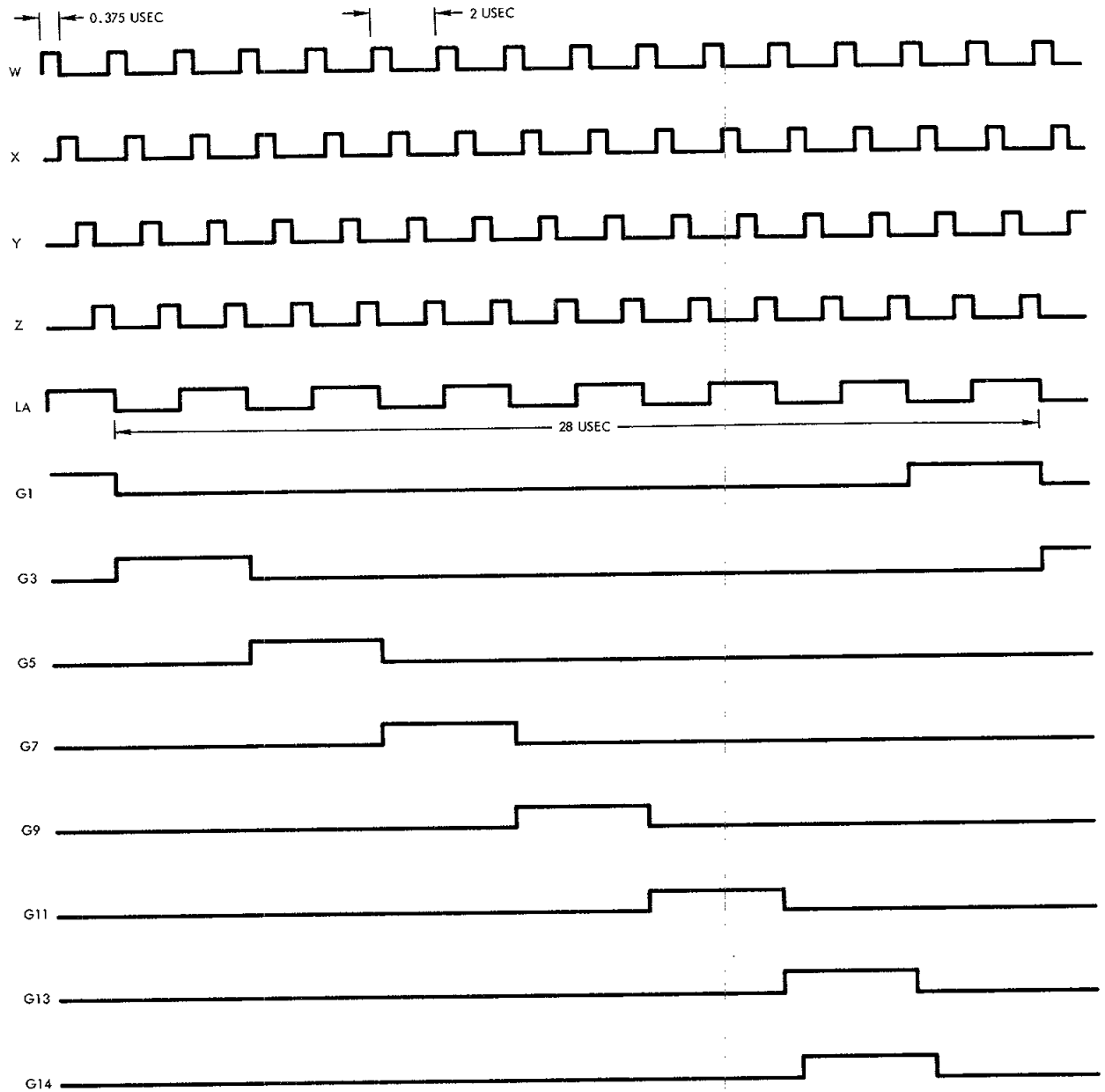
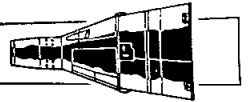

BIT TIMING TABLE

BIT TIME (BT)	LA	GATE	BIT TIME (BT)	LA	GATE	BIT TIME (BT)	LA	GATE
1	"1"	G1	6	"0"	G7	11	"1"	G11
2	"0"	G3	7	"1"	G7	12	"0"	G13
3	"1"	G3	8	"0"	G9	13	"1"	G13
4	"0"	G5	9	"1"	G9	14	"0"	G1
5	"1"	G5	10	"0"	G11			

Figure 8-21 Computer Clock and Bit Timing

# PROJECT GEMINI

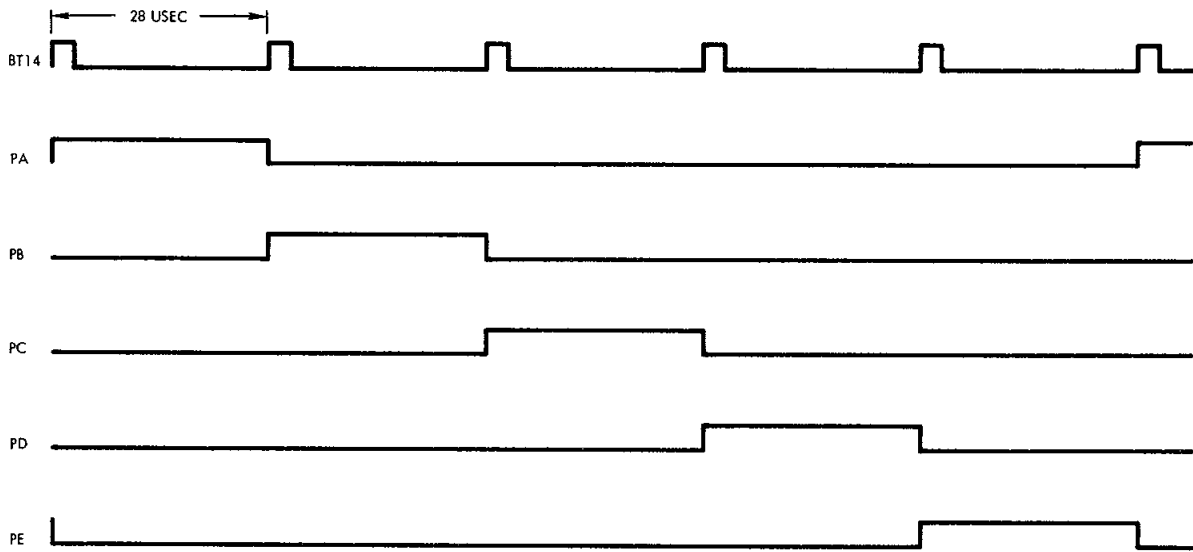
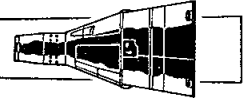

Figure 8-22 Computer Phase Timing

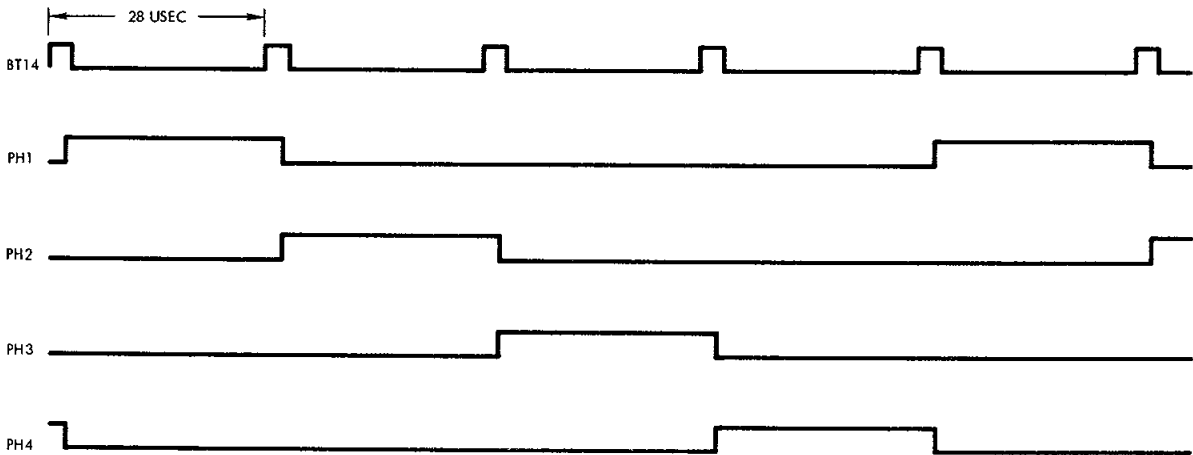

Figure 8-23 Processor Phase Timing



# PROJECT GEMINI



## Memory

The computer memory is a random-access, coincident-current, ferrite array with nondestructive readout. The basic storage element is a two-hole ferrite core. The nondestructive read property makes it possible to read or write serially or in series-parallel, thereby allowing operation with a serial arithmetic unit without a separate buffer register. The memory array can store 4096 words, or 159,744 bits. All memory words of 39 bits are divided into three syllables of 13 bits each. Data words (25 bits and a sign) are normally stored in the first two syllables, and instruction words (13 bits) are intermixed in all three syllables. Once the spacecraft has been removed from the hangar area, it is not possible to modify the third syllable of any memory word. Modification of data stored in syllables 0 and 1 can be accomplished at the launch site through interface with the Manual Data Insertion Unit or the Digital Command System. It can also be accomplished in flight, on spacecraft 8 through 12, using the Auxiliary Tape Memory (ATM).

As shown on Figure 8-24, the memory is a 64 x 64 x 39 bit array of nondestructive readout elements. Physically, it consists of a stack of 39 planes (stacked in the Z dimension), with each plane consisting of a 64 x 64 array of cores. The memory is logically subdivided into smaller parts to increase the program storage efficiency. The Z dimension is divided into three syllables (SYL 0 through SYL 2), with each syllable consisting of 13 bits. The X-Y plane is divided into 16 sectors (SEC 00 through SEC 07, and SEC 10 through SEC 17), with sector 17 being defined as the residual sector.

A memory word is defined as the 39 bits along the Z dimension and is located at one of the 4096 possible X-Y grid positions. An instruction word or command requires 13 bits, and is coded in either syllable 0, 1, or 2 of a memory word. A data word

# PROJECT GEMINI

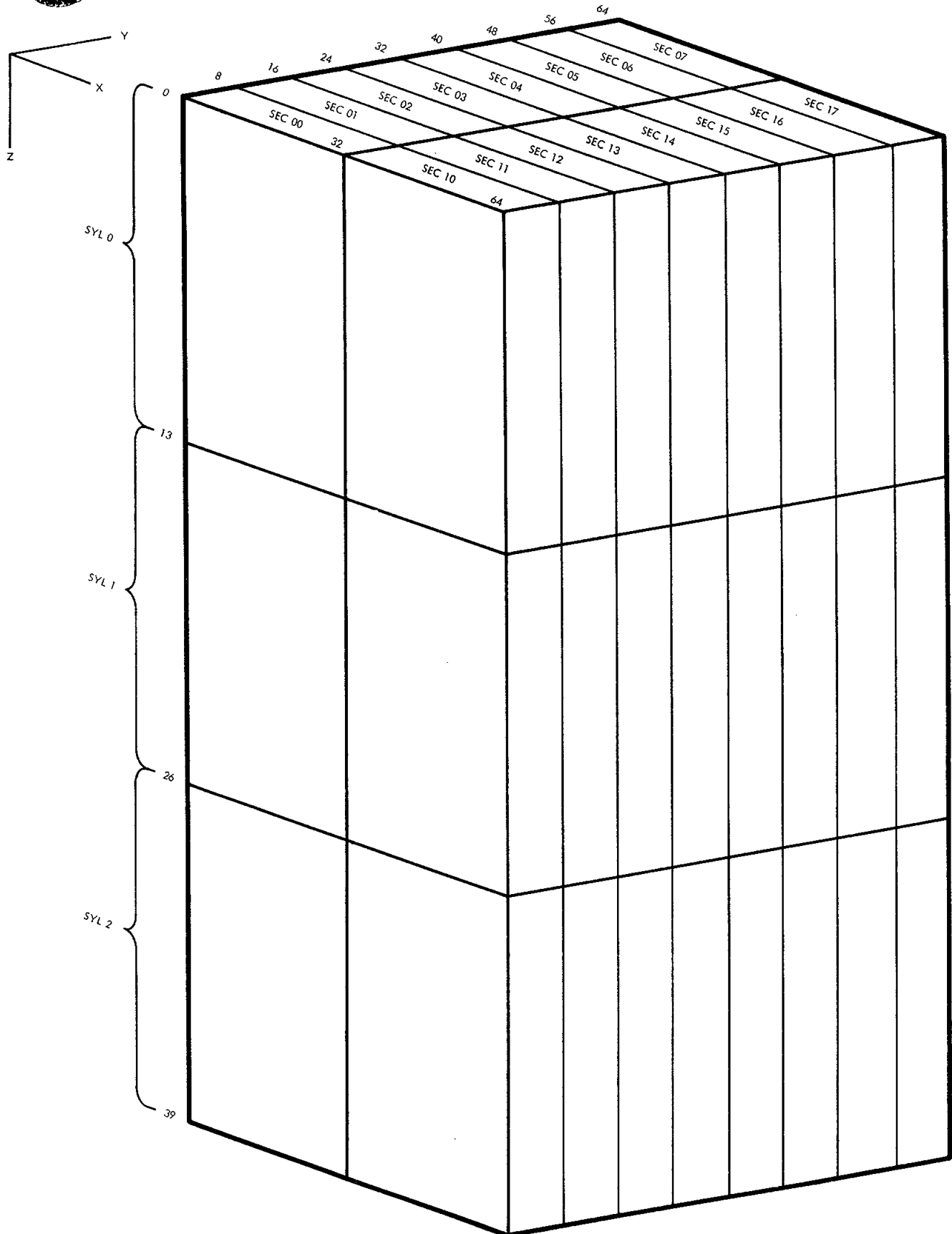
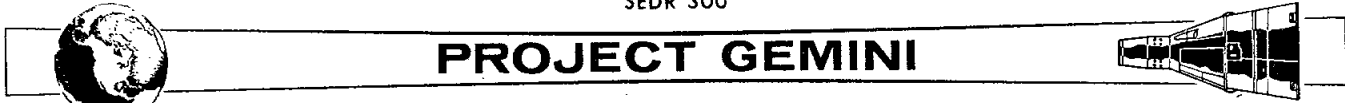

Figure 8-24 Computer Memory Functional Organization



# PROJECT GEMINI



requires 26 bits, and is always coded in syllables 0 and 1 of a memory word. Information stored in syllable 2 can be read as a short data word by using a special mode of operation primarily used to check the contents of the memory.

## NOTE

The operation codes mentioned in the subsequent paragraphs are described in the Instruction and Data Words paragraph.

## Instruction List

The instructions which can be executed by the computer are as follows:

<u>Operation Code</u>	<u>Instruction</u>
0000	HOP. The contents of the memory location specified by the operand address are used to change the next instruction address. Four bits identify the next sector, nine bits are transferred to the instruction address counter, two bits are used to condition the syllable register, and one bit is used to select one of the two data word modes.
0001	DIV (divide). The contents of the memory location specified by the operand address are divided by the contents of the accumulator. The 24-bit quotient is available in the quotient delay line during the fifth word time following the DIV.



# PROJECT GEMINI



Operation Code (cont)

Instruction (cont)

- 0010 PRO (process input or output). The input or output specified by the operand address is read into, or loaded from, the accumulator. An output command clears the accumulator to zero if address bit A9 is a 1. The accumulator contents are retained if A9 is a 0. (Refer to Table 8-1 for a list of the PRO instructions.)
- 0011 RSU (reverse subtract). The contents of the accumulator are subtracted from the contents of the specified memory location. The result is retained in the accumulator.
- 0100 ADD. The contents of the memory location specified by the operand address are added to the contents of the accumulator. The result is retained in the accumulator.
- 0101 SUB (subtract). The contents of the memory location specified by the operand address are subtracted from the contents of the accumulator. The result is retained in the accumulator.
- 0110 CLA (clear and add). The contents of the memory location specified by the operand address are transferred to the accumulator.



**PROJECT GEMINI**



Operand Address		Signal
X (Bits A1-A3)	Y (Bits A4-A6)	
0	0	Digital Command System shift pulse gate
0	1	Data Transmission System control gate
0	2	Time Reference System data and timing pulses
0	3	Digit magnitude weight 1
0	4	Reset data ready, enter, and readout
0	5	Digit select weight 1
0	6	Memory strobe
1	0	Computer ready
1	1	Drive counters to zero
1	2	Enter
1	3	Digit magnitude weight 2
1	4	Display device drive
1	5	Digit select weight 2
1	6	Autopilot scale factor
2	0	Pitch resolution
2	1	Select X counter
2	2	Aerospace Ground Equipment data link
2	3	Digit magnitude weight 4
2	5	Digit select weight 4
2	6	Reset start computation

Table 8-1. PRO Instruction Programming (1 of 3)



**PROJECT GEMINI**



Operand Address		Signal
X (Bits A1-A3)	Y (Bits A4-A6)	
3	0	Yaw resolution
3	1	Select Y counter
3	2	Aerospace Ground Equipment data clock
3	3	Digit magnitude weight 8
3	4	Read Manual Data Insertion Unit insert data
3	6	Reset radar ready
4	0	Roll resolution
4	1	Elapsed time control and Time Reference System control reset/ATM wind-rewind Reset
4	3	Computer malfunction
4	4	ATM verify/repro command
4	6	Second stage engine cutoff
5	0	Computer running
5	1	Time to start re-entry calculations control /ATM wind command
5	2	Time to reset control/ATM rewind command
5	3	Write output processor
5	4	Read delta velocity
5	5	Input processor time
5	6	Time to retrofire control
6	3	Read pitch gimbal
6	4	Read roll gimbal

Table 8-1. PRO Instruction Programming (2 of 3)



# PROJECT GEMINI



Operand Address		Signal
X (Bits A1-A3)	Y (Bits A4-A6)	
6	5	Ready yaw gimbal
7	0	Pitch error command
7	1	Yaw error command
7	2	Roll error command

Table 8-1. PRO Instruction Programming (3 of 3)



# PROJECT GEMINI

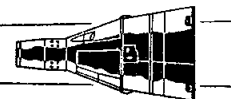

Operation Code (cont)

Instruction (cont)

- 0111                   AND. The contents of the memory location specified by the operand address are logically ANDed, bit-by-bit, with the contents of the accumulator. The result is retained in the accumulator.
- 1000                   MPY (multiply). The contents of the memory location specified by the operand address are multiplied by the contents of the accumulator. The 24 high-order bits of the multiplier and multiplicand are multiplied together to form a 26-bit product which is available in the product delay line during the second word time following the MPY.
- 1001                   TRA (transfer). The operand address bits (A1 through A9) are transferred to the instruction address counter to form a new instruction address. The syllable and sector remain unchanged.
- 1010                   SHF (shift). The contents of the accumulator are shifted left or right, one or two places, as specified by the operand address, according to the following table:



PROJECT GEMINI



Operation Code (cont)

Instruction (cont)

<u>Command</u>	<u>Operand Address</u>	
	<u>X (Bits A1-A3)</u>	<u>Y (Bits A4-A6)</u>
Shift left one place	*	3
Shift left two places	*	4
Shift right one place	1	2
Shift right two places	0	2

\* Insignificant

If an improper address code is given, the accumulator is cleared to zero. While shifting left, 0's are shifted into the low-order positions; while shifting right, the sign bit condition is shifted into the high-order positions.

1011

TMI (transfer on minus accumulator sign). If the sign is positive (0), the next instruction in sequence is chosen (no branch). If the sign is negative (1), the nine bits of operand address become the next instruction address (perform branch). The syllable and sector remain unchanged.

1100

STO (store). The contents of the accumulator are stored in the memory location specified by the operand address. The contents of the accumulator are also retained for later use.



# PROJECT GEMINI



## Operation Code (cont)

## Instruction (cont)

- 1101 SPQ (store product or quotient). The product is available on the second word time following an MPY. The quotient is available on the fifth word time following a DIV. The product or quotient is stored in the memory location specified by the operand address.
- 1110 CLD (clear and add discrete). The state of the discrete input selected by the operand address is read into all accumulator bit positions. (Refer to Table 8-2 for a list of the CLD instructions.)
- 1111 TNZ (transfer on non-zero). If the contents of the accumulator are zero, the next instruction in sequence is chosen (no branch); if the contents are non-zero, the nine bits of operand address become the next instruction address (perform branch). The syllable and sector remain unchanged.

### NOTE

The instructions mentioned in the subsequent paragraphs (e.g., HOP, TRA, TMI, and TNZ) are described more completely in the Instruction Information Flow paragraph.

## Instruction Sequencing

The instruction address is derived from an instruction counter and its associated



**PROJECT GEMINI**



Operand Address		Signal
X (Bits A1-A3)	Y (Bits A4-A6)	
0	0	Radar ready
0	1	Computer mode 2
0	2	Spare
0	3	Processor timing phase 1
0	4	Spare
1	0	Data ready
1	1	Computer mode 1
1	2	Start computation
1	3	X zero indication
1	4	ATM clock
2	0	Enter
2	1	Instrumentation System sync
2	2	Velocity error count not zero
2	3	Aerospace Ground Equipment request
2	4	Spare
3	0	Readout
3	1	Computer mode 3
3	2	Spare
3	3	ATM on
3	4	ATM data channel 2
4	0	Clear

Table 8-2. CLD Instruction Programming (1 of 2)



**PROJECT GEMINI**



Operand Address		Signal
X (Bits A1-A3)	Y (Bits A4-A6)	
4	1	ATM mode control 1
4	2	Simulation mode command
4	3	ATM end of tape
4	4	ATM data channel 3
5	0	Time to start re-entry calculations
5	1	ATM mode control 2
5	2	Y zero indication
5	3	ATM data 1
5	4	Spare
6	0	Digital Command System ready
6	1	Fade-in discrete
6	2	Z zero indication
6	3	Umbilical disconnect
6	4	Spare
7	0	Instrumentation System request
7	1	Abort transfer
7	2	Aerospace Ground Equipment input data
7	3	Spare
7	4	Spare

Table 8-2. CLD Instruction Programming (2 of 2)



# PROJECT GEMINI



address register. To address an instruction, the syllable, sector, and word position within the sector (one of 256 positions) must be defined. The syllable and sector are defined by the contents of the syllable register (two-bit code, three combinations) and sector register (four-bit code, 16 combinations). These registers can be changed only by a HOP instruction. The word position within the sector is defined by the instruction address counter. The instruction address count is stored serially in a delay line; and normally each time it is used to address a new instruction, a one is added to it so that the instruction locations within a sector can be sequentially scanned. The number stored in the counter can be changed by either a TRA, TMI, or TNZ instruction, with the operand address specifying the new number. A HOP instruction can also change the count, with the new instruction location coming from a data word.

## Instruction and Data Words

The instruction word consists of 13 bits and can be coded in any syllable of any memory word. The word is coded as follows:

<u>Bit Position</u>	1	2	3	4	5	6	7	8	9	10	11	12	13
<u>Bit Code</u>	A1	A2	A3	A4	A5	A6	A7	A8	A9	OP1	OP2	OP3	OP4

The four operation bits (OP1 through OP4) define one of 16 instructions, the eight operand address bits (A1 through A8) define a memory word within the sector being presently used, and the residual bit (A9) determines whether or not to read the data residual. If the A9 bit is a 1, the data word addressed is always located in the last sector (sector 17). If the A9 bit is a 0, the data word addressed is read from the sector defined by the contents of the sector register. This feature allows data locations to be available to instructions stored anywhere in the



# PROJECT GEMINI



memory .

The data word consists of 25 magnitude bits and a sign bit. Numbers are represented in two's-complement form, with the low-order bits occurring at the beginning of the word and the sign bit occurring after the highest-order bit. The binary point is placed between bit positions 25 and 26. The bit magnitude number also denotes the binary weight of the position. For example, M16 represents  $2^{-16}$ .

For the HOP instruction, the next instruction address is coded in a data word that is read from the memory location specified by the operand address of the HOP word.

The codings of a numerical data word and a HOP word are as follows:

<u>Bit Position</u>	1	2	3	4	5	6	7	8	9	10	11	12	13
<u>Data Word</u>	M25	M24	M23	M22	M21	M20	M19	M18	M17	M16	M15	M14	M13
<u>HOP Word</u>	A1	A2	A3	A4	A5	A6	A7	A8	A9	S1	S2	S3	S4
<u>Bit Position</u>	14	15	16	17	18	19	20	21	22	23	24	25	26
<u>Data Word</u>	M12	M11	M10	M9	M8	M7	M6	M5	M4	M3	M2	M1	S
<u>HOP Word</u>	-	SYA	SYB	-	S5	-	-	-	-	-	-	-	-

For the HOP word, eight address bits (A1 through A8) select the next instruction (one of 256) within the new sector, the residual bit (A9) determines whether or not the next instruction is located in the residual sector, the sector bits (S1 through S4) select the new sector, and the syllable bits (SYA and SYB) select the new syllable according to the following table:

<u>Syllable</u>	<u>SYB</u>	<u>SYA</u>
0	0	0
1	0	1
2	1	0



# PROJECT GEMINI

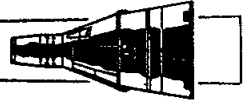

Roll and yaw servo loops utilize resolvers to correlate gimbal angles with gyro outputs. Inner roll and yaw gimbals are controlled by a coordinate transformation resolver mounted on the pitch gimbal. When the spacecraft is at any pitch attitude other than 0 or 180 degrees, some roll motion is sensed by the yaw gyro and some yaw motion is sensed by the roll gyro. The amount of roll motion sensed by the yaw gyro is proportional to the pitch gimbal angle. The resolver mounted on the pitch gimbal angle. Resolver output is then conditioned in the same manner as in the pitch servo loop to drive inner roll and yaw gimbals.

The outer roll gimbal is servo driven from the inner roll gimbal resolver. A coordinate transformation resolver mounted on the inner roll gimbal, monitors the angle between inner roll and yaw gimbals. If the angle is anything other than 90 degrees an error signal is produced by the resolver. The error signal is conditioned in the same manner as in the pitch servo loop to drive the outer roll gimbal. One additional circuit (phase sensitive electronics) is included in the outer roll servo loop. The outer roll gimbal torque motor is mounted on the platform housing and moves about the stable element with the spacecraft. As the spacecraft moves through 90 degrees in yaw, the direction that the outer roll gimbal torque motor must rotate to compensate for spacecraft roll, reverses. Phase sensitive electronics and a resolver provide the phase reversal necessary for control. The resolver is used to measure rotation of the yaw gimbal about the yaw axis. As the gimbal rotates through 90 degrees in yaw, the resolver



## PROJECT GEMINI

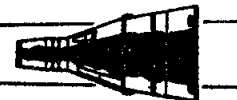

output changes phase. Resolver output is compared to a reference phase by the phase sensitive electronics. When the resolver output changes phase, the torque motor drive signal is reversed.

### Pre-Launch Alignment

The IMU is the inertial reference for back-up ascent guidance and must therefore be aligned for that purpose. The platform is aligned to local vertical and the launch azimuth. Platform X and Y accelerometers are the reference for local vertical alignment. When the platform is aligned to the local vertical, X and Y accelerometers are level and cannot sense any acceleration due to gravity. If any acceleration is sensed, the platform is not properly aligned and must be torqued until no error signal exists. The accelerometer output is used by AGE equipment to generate torque signals for the gyros. When the gyro is torqued it produces an error signal which is used to align the gimbal. The outer roll gimbal synchro output is compared with a signal representing the launch azimuth by AGE equipment. The error signal is conditioned by AGE equipment and applied to the yaw gyro torque generator. The yaw gyro signal generator then produces a signal proportional to the input torque. Gyro output is coordinated by a resolver mounted on the pitch gimbal. Since the spacecraft is in a 90 degree pitch up attitude essentially all of the yaw gyro output is transferred to roll gimbal control electronics. The electronics drive the roll gimbals until no error exists between synchro output and the AGE reference signal. When no error signal exists, the platform is aligned to the launch azimuth.



# PROJECT GEMINI



## Orbit Alignment

Alignment of the platform in orbit is accomplished by referencing it to the horizon sensors. Placing the platform mode selector in SEF or BEF position will reference it to the horizon sensors. Pitch and roll horizon sensor outputs are compared with platform pitch and outer roll synchro outputs. Differential amplifiers produce torque control signals proportional to the difference between sensor and synchro outputs. Torque control signals are used to drive pitch and roll gyro torque generators. Gyro signal generator outputs are then used by gimbal control electronics to drive platform gimbals. When synchro and horizon sensor outputs balance, the pitch and roll gimbals are aligned to the local vertical. The yaw gimbal is aligned to the orbit plane through a gyro compass loop. If yaw errors exist, the roll gyro will sense a component of orbit rate. The roll gyro output is used through a gyro compass loop to torque the yaw gyro. Yaw gyro output is then used by gimbal control electronics to drive the yaw gimbal. When the roll gyro no longer senses a component of orbit rate, the yaw gimbal is aligned to the orbit plane. All three gimbals are now aligned and will remain aligned as long as SEF or BEF modes are used. The pitch gyro will be continuously torqued (at the orbit rate) to maintain a horizontal attitude.

### **NOTE**

If horizon sensors lose track while the platform is in SEF or BEF modes, the platform is automatically switched to ORB RATE mode.



# PROJECT GEMINI

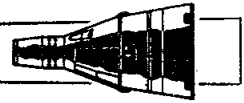

## Orbit Rate Circuit

The orbit rate circuit is used to maintain alignment to the local vertical during orbit maneuvers. Local vertical cannot be provided by horizon sensors during maneuvers because they will lose track. To maintain a horizontal attitude with no external reference, the pitch gyro is torqued at approximately four degrees per minute. The torque represents the spacecraft orbit rate. Torque is obtained by placing a DC bias on the output of the pitch differential amplifier. The bias drives the pitch gyro torquer at approximately the orbit rate. Orbit rate bias is adjustable and can be set to match orbits of various altitudes.

## Phase Angle Shift Technique

Phase Angle Shift Technique (PAST) is a method of improving gyro drift repeatability. One of the factors which affects gyro drift is spin motor rotor unbalance. The effect of unbalance will vary with changes in the point of lock on with the synchronous motor's rotating field. The spin motor can lock on to a different point each time it is started. Drift errors due to rotor unbalance are in the order of 0.5 degrees per hour. PAST provides a means of reducing drift errors by a factor of ten. To cancel drift errors, PAST shifts the phase of spin motor excitation 30 degrees at regular intervals. Shifting the phase causes the rotor to lock on a different point each time the phase is shifted. Drifts now tend to cancel and become predictable. (When drift is predictable it can be compensated for.) All three gyro torque control loops contain drift compensation circuits. The drift compensation circuits apply a dc bias to each gyro torque generator. Drift compensation torques the gyro in the opposite



# PROJECT GEMINI



direction as predictable drift, maintaining a stable attitude.

## Attitude Malfunction Detection

An attitude malfunction detection circuit performs self checks of gyro signal generator excitation, gimbal control signals, logic timing signals, and critical voltages. Gyro signal generator excitation is checked for presence and proper amplitude. Gimbal control signals are checked for the length of time signals are present. The logic timing signal (28.8kc) is checked for presence. Critical voltages (+22vdc, -3vdc, +12vdc) are checked for presence. If a malfunction is detected, an ATT light on the control panel is automatically illuminated. If momentary malfunctions occur, the ATT indicator can be restored to normal operation by pressing the RESET button.

### **NOTE**

If the attitude measurement circuits malfunction, the acceleration indications are not reliable. Accelerometer axes will not be properly aligned and indications are along unknown axes.

## Acceleration Measurement

Acceleration is measured along three mutually perpendicular axes of the inertial platform. Sensing devices are three miniature pendulous accelerometers. The



# PROJECT GEMINI



accelerometers are mounted in the platform pitch block and measure acceleration along gyro x, y, and z axes. Accelerometer signal generators produce signals whose phase is a function of the direction of acceleration. Signal generator output is used to control torque rebalance pulses. The torque rebalance pulses drive accelerometer pendulums toward their null position. Rebalance pulses are dc current whose polarity is controlled by signal generator output. The polarity of rebalance pulses indicates the direction of acceleration and the algebraic sum of the pulses indicates the amount of acceleration. Rebalance pulses are supplied to the spacecraft digital computer where they are used for computations and incremental velocity displays.

## Torque Rebalance Loop

Three electrically identical torque rebalance loops are used to control accelerometer pendulum positions. Normally an analog loop would be used for this purpose; however, if an analog loop were used, the output would have to be converted to digital form for use in the computer. To eliminate the need for an analog to digital converter, a pulse rebalance loop is used. Short duration 184 milliamperere dc current pulses drive the accelerometer pendulum in one direction until it passes through null. Pulses are applied at the rate of 3.6kc. When the pendulum passes through null, signal generator output changes phase. The signal generator output is demodulated to determine the direction of the pendulum from null. Demodulator output is used by logic circuits to control the polarity of rebalance pulses. If acceleration is being sensed, there will be more pulses of one polarity than the other. If no acceleration is being sensed, the number of pulses of



# PROJECT GEMINI



each polarity will be equal. In addition to controlling the polarity of rebalance pulses, logic circuits set up precision timing of the pulses. Precision frequency inputs from the timing circuits are the basis for rebalance pulse timing. Precise timing is essential because the amount of pendulum torque depends on the length of the current pulse. All pulses are precisely the same duration and amplitude, therefore total torque is dependent only on the algebraic sum of the applied pulses. Each time a rebalance pulse is applied to the accelerometer torquer, a pulse is also provided to the computer. Algebraic summation of the rebalance pulses is performed by the computer.

## Pulse Rebalance Current Supply

A pulse rebalance current supply provides the required current for torque rebalance. Since acceleration measurements are based on the number of torque pulses it is essential that all pulses be as near identical as possible. To maintain a stable current, a negative feedback circuit is employed. The supply output is passed through a precision resistor and the voltage drop across the resistor compared to a precision voltage reference. Errors detected by the comparison are used in the feedback circuit to correct any deviations in current. To further enhance stability both the current supply and the precision voltage reference are housed in a temperature controlled oven.

## Accelerometer Dither

A pendulous accelerometer, unlike a gyro, has an inherent mass unbalance. The mass unbalance is necessary to obtain the pendulum action. Due to the unbalance, perfect flotation of the pendulous gimbal cannot be achieved and consequently



# PROJECT GEMINI



pressure is present on the gimbal bearing. To minimize the stiction effect, caused by bearing friction, a low amplitude oscillation is imposed on the gimbal. The oscillation (dither) prevents the gimbal from resting on its bearing long enough to cause stiction. To obtain gimbal oscillation, two signals are required: a 100 cps dither signal and a dc field current. The dc field current is superimposed on the signal generator excitation and creates a magnetic field around the gimbal. The 100 cps dither is applied to a separate (modulator) coil. The dither signal beats against the dc field, causing the gimbal to oscillate up and down. The dither motion is not around the output axis and consequently no motion is sensed by the signal generator.

## Accelerometer Malfunction Detection

An acceleration malfunction detection circuit performs self checks of incremental velocity pulses and critical voltage. Incremental velocity pulses from each of the three axes are checked for presence. If pulses are absent longer than 0.35 seconds, it indicates that a flip flop did not reset between set pulses. The critical voltage (+12 vdc) is checked for presence. If a malfunction is detected, an ACC light on the control panel is automatically illuminated. If momentary malfunctions occur, the accelerometer malfunction circuit can be restored to normal operation by pressing the RESET button.

## **NOTE**

Malfunction of the accelerometer circuits  
does not affect attitude measurements.



# PROJECT GEMINI

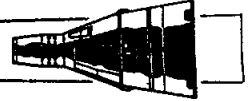

## AUXILIARY COMPUTER POWER UNIT

The Auxiliary Computer Power Unit (ACPU) is used in conjunction with the IGS power supply to maintain the correct dc voltages at the computer. The computer cannot function properly on low voltage either as a transient or a depression. Abnormal voltages can cause permanent changes in the computer memory. Three types of circuits are provided in the ACPU to prevent a low voltage condition at the computer. The first circuit is a transient sense and auxiliary power control circuit. The second circuit is a low voltage sense and power control circuit and the third is auxiliary power. The ACPU is turned on and off with the COMPUTER ON-OFF switch.

### Transient Sense Circuit

The transient sense circuit is designed to sense and correct transient low voltage conditions. A series type transistor voltage regulator holds auxiliary power off the line as long as IGS power supply computer voltage regulator voltage is normal. If regulator voltage momentarily drops below a minimum of 17.5 volts, the transient sense circuit detects the drop and turns on the series regulator. The regulator then places auxiliary power on the line and maintains voltage at the desired level.

### Low Voltage Sense Circuit

A low voltage sense circuit prevents the computer from operating on low voltage. When the computer is turned on, the low voltage sense circuit insures that spacecraft bus voltage is above 21 volts before allowing power to be applied to the



# PROJECT GEMINI



computer. If the computer is already on when a low voltage condition occurs, the transient sense circuit will maintain normal voltage for 100 milliseconds. If spacecraft bus voltage is not back to normal after 100 milliseconds the low voltage sense circuit initiates a controlled shutdown of the computer. Computer power is controlled through contacts of a relay in the low voltage sense circuit. When the low voltage sense circuit detects a voltage depression it deenergizes the relay. Contacts of the relay initiate a computer shutdown in a manner identical with the computer power switch. When the low voltage sense circuit turns off the computer it also breaks power to all ACPU circuits except low voltage sense. If power were not broken to the transient sense circuit it would attempt to maintain normal voltage at the computer. In attempting to maintain normal voltage the auxiliary power capability would be exceeded.

## Auxiliary Power

Auxiliary power consists of a battery and a trickle charger. A 0.5 ampere-hour nickel cadmium battery is used to supply computer power during spacecraft bus low voltage transients. The battery will supply up to 9.8 amperes for periods of 100 milliseconds or less. A trickle charger is provided to maintain a full charge on the battery. The charger consists of a transistor oscillator, transformer, and rectifier. The oscillator changes static power supply dc voltage to ac. The ac voltage is then stepped up with a transformer and changed back to dc by a full wave diode rectifier. Rectifier output is then applied, through a current limiting resistor, to the battery. The resistor limits charging current to 25 milliamperes. Provision is included to charge the battery from an external source if desired.



# PROJECT GEMINI



## DIGITAL COMPUTER

### SYSTEM DESCRIPTION

#### General

The Digital Computer, hereinafter referred to as the computer, is a binary, fixed-point, stored-program, general-purpose computer, used to perform on-board computations. The computer is 18.90 inches high, 14.50 inches wide, and 12.75 inches deep. It weighs 58.98 pounds. External views of the computer are shown in Figure 8-20. The major external characteristics are summarized in the accompanying legend.

Using inputs from other spacecraft systems, along with a stored program, the computer performs the computations required during the pre-launch, insertion, catch-up, rendezvous, and re-entry phases of the mission. In addition, the computer provides back-up guidance for the launch vehicle during ascent.

#### Inputs and Outputs

The computer is interfaced with the Inertial Platform, System Electronics, Inertial Guidance System Power Supply, Auxiliary Computer Power Unit, Manual Data Insertion Unit, Time Reference System, Digital Command System, Attitude Display, Attitude Control and Maneuver Electronics, Titan Autopilot, Auxiliary Tape Memory (spacecraft 8 through 12), Pilots' Control and Display Panel, Incremental Velocity Indicator, Instrumentation System, and Aerospace Ground Equipment. In connection with these interfaces, the computer inputs and outputs include the following:

##### Inputs

40 discrete

3 incremental velocity

PROJECT GEMINI

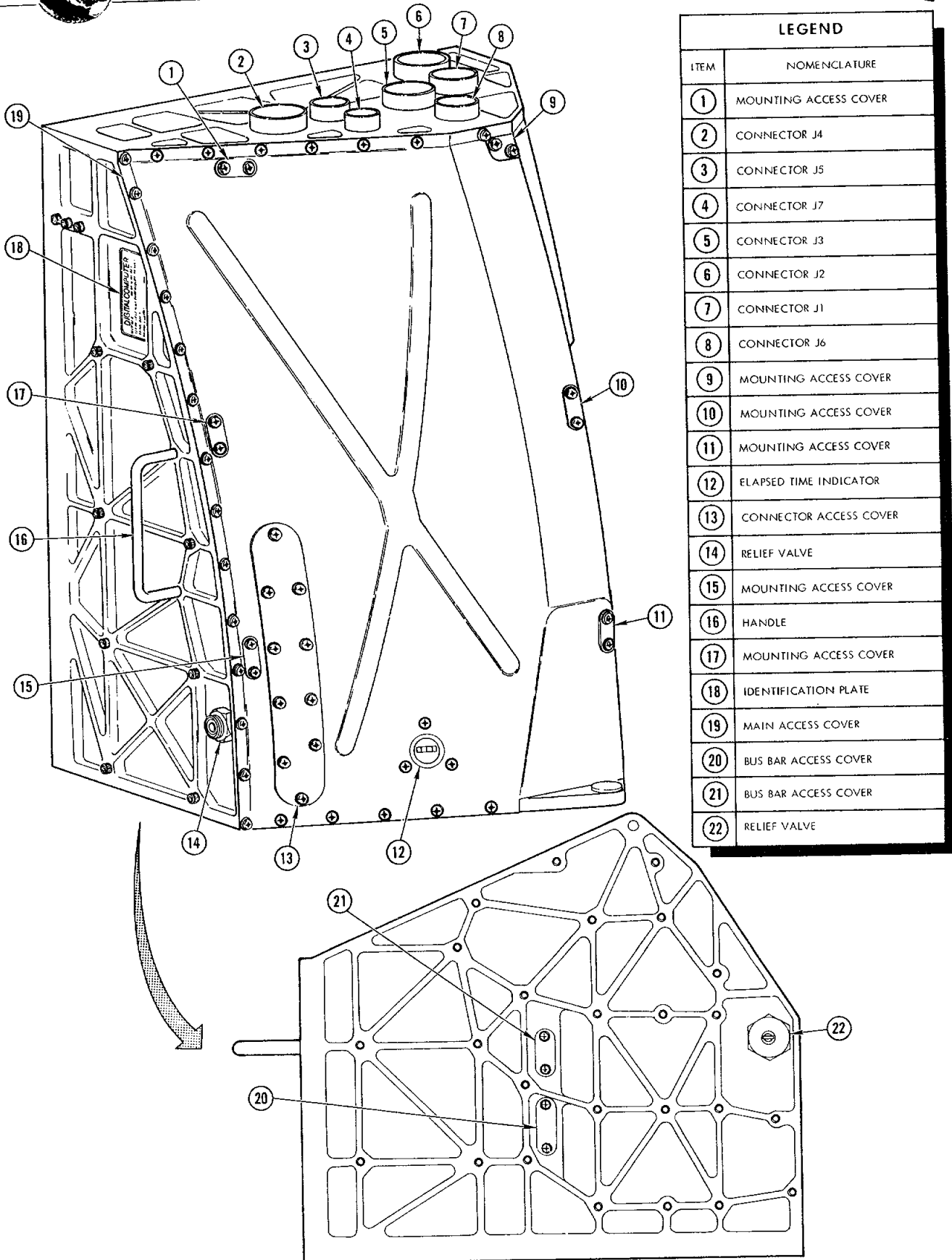
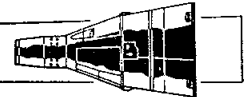

Figure 8-20 Digital Computer



# PROJECT GEMINI



## Inputs (cont)

- 3 gimbal angle
- 2 high-speed data (500 kc)
- 1 low-speed data (3.57 kc)
- 1 low-speed data (182 cps)
- 1 input and read-back (99 words)
- 6 dc power (5 regulated, 1 unregulated)
- 1 ac power (regulated)

## Outputs

- 30 discrete
  - 3 steering command
  - 3 incremental velocity
  - 1 decimal display (7 digits)
  - 1 telemetry (21 digital data words)
  - 1 low-speed data (3.57 kc)
  - 1 low-speed data (182 cps)
  - 3 dc power (regulated)
  - 1 ac power (regulated, filtered)

## Operational Characteristics

The major operational characteristics of the computer are as follows:

### Type

Binary, fixed-point, stored-program, general-purpose



# PROJECT GEMINI



## Memory

Random-access, nondestructive-readout

Flexible division between instruction and data storage

4096 addresses, 39 bits per address

13 bits per instruction word

26 bits per data word

## Arithmetic Times

Instruction cycle - 140 usec

Divide requires 6 cycles

Multiply requires 3 cycles

All other instruction require 1 cycle each

Other instructions can be programmed concurrently with multiply and divide

## Clock Rates

Arithmetic bit rate - 500 kc

Memory cycle rate - 250 kc

## Controls and Indicators

The computer itself contains no controls and indicators, with the exception of the elapsed time indicator. However, the computer can be controlled by means of four switches located on the Pilots' Control and Display Panel: a two-position ON-OFF switch, a seven-position mode switch, a push-button START Computation switch, and a push-button RESET switch.



# PROJECT GEMINI

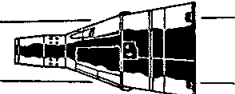

## SYSTEM OPERATION

### Power

The computer receives the ac and dc power required for its operation from the Inertial Guidance System (IGS) Power Supply. The regulated dc power supplied to the computer is buffered in the IGS Power Supply in a manner that eliminates any loss in regulation due to transients that occur in the spacecraft prime power source. Actual power interruptions and depressions are buffered by the IGS Power Supply and the Auxiliary Computer Power Unit. The power inputs received from the IGS Power Supply are as follows:

- (a) 26 vac and return
- (b) +28 vdc filtered and return
- (c) +27.2 vdc and return
- (d) -27.2 vdc and return
- (e) +20 vdc and return
- (f) +9.3 vdc and return

The application of all power is controlled by the ON-OFF switch on the Pilots' Control and Display Panel. When the switch is turned on, the computer elapsed time indicator starts operating and a power control signal is supplied to the IGS Power Supply by the computer. This signal causes power to be transferred to the computer. When the switch is turned off, the computer elapsed time indicator stops operating and the power control signal is terminated to remove power from the computer.



# PROJECT GEMINI

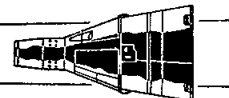

Within the computer, the 26 vac power is used by magnetic modulators to convert dc analog signals to ac analog signals. This power is also used by a harmonic filter to develop a 16 vac, 400 cps filtered gimbal angle resolver excitation signal. The +28 vdc power is used by computer power sequencing circuits. The +27.2 vdc, -27.2 vdc, +20 vdc, and +9.3 vdc power is used by power regulators to develop +25 vdc, - 25 vdc, and +8 vdc regulated power. This regulated power is used by logic circuits throughout the computer, and is supplied to some of the other spacecraft systems.

## Basic Timing

The basic computer timing is derived from an 8 mc oscillator. The 8 mc signal is counted down to generate four clock pulses (called W, X, Y, and Z) (Figure 8-21). These clock pulses are the basic timing pulses from which all other timing is generated. The width of each clock pulse is 0.375 usec and the pulse repetition frequency is 500 kc. The bit time is 2 usec, and a new bit time is considered as starting each time the W clock pulse starts. Eight gate signals (G1, G3, G5, G7, G9, G11, G13, and G14) are generated, each lasting two bit times. The first and second bit times of a particular gate are discriminated by use of a control signal (called IA) which is on for odd bit times and off for even bit times. Fourteen bit times make up one phase time, resulting in a phase time length of 28 usec (Figure 8-22). Five phases (PA through PE) are required to complete a computer instruction cycle, resulting in an instruction cycle length of 140 usec. Special phase timing, consisting of four phases (PH1 through PH4) (Figure 8-23), is generated for use by the input processor and the output processor. This timing is independent of computer phase timing but is synchronized with computer bit timing.



# PROJECT GEMINI

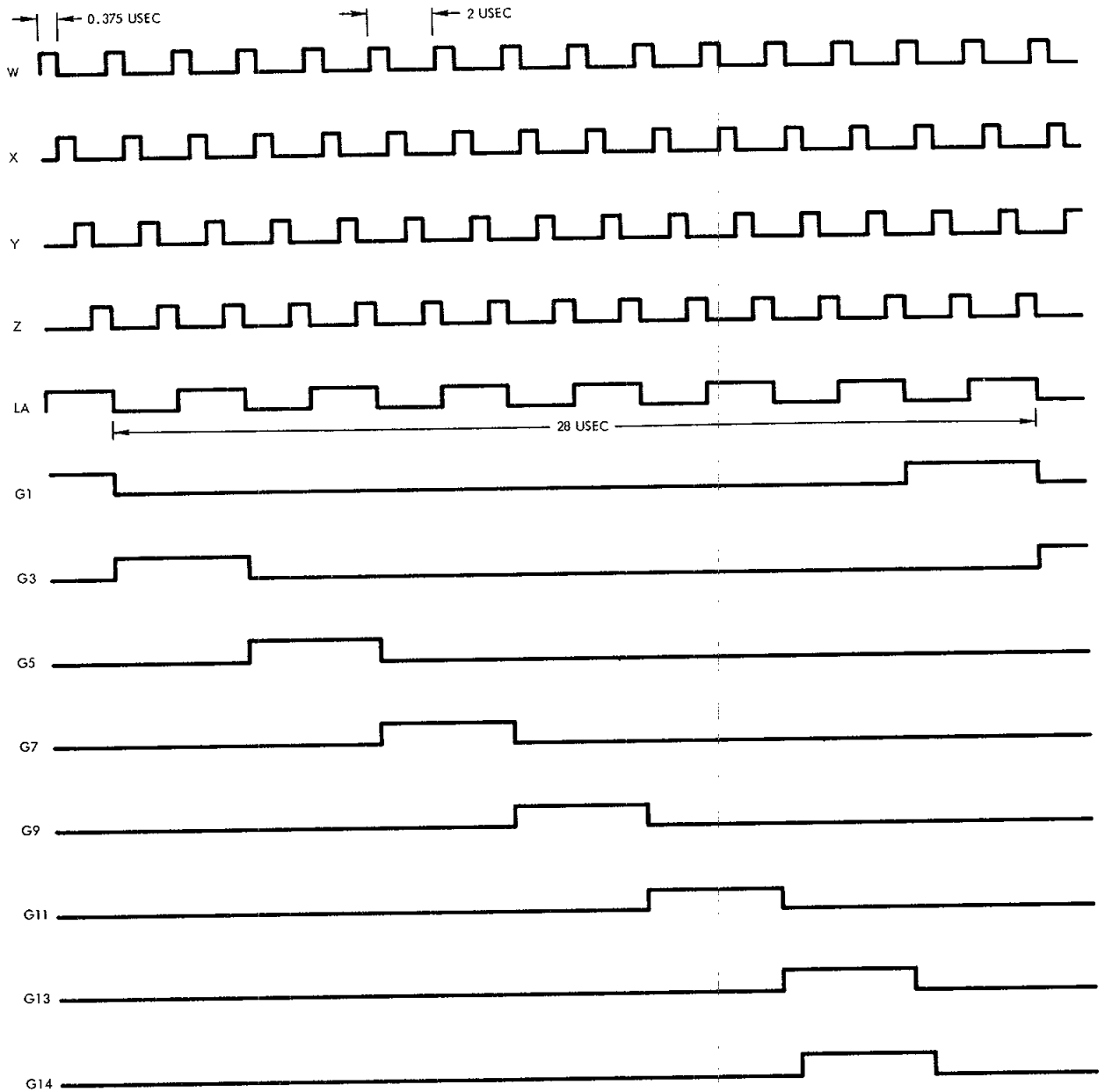
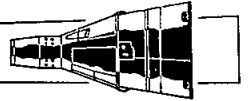

BIT TIMING TABLE

BIT TIME (BT)	LA	GATE	BIT TIME (BT)	LA	GATE	BIT TIME (BT)	LA	GATE
1	"1"	G1	6	"0"	G7	11	"1"	G11
2	"0"	G3	7	"1"	G7	12	"0"	G13
3	"1"	G3	8	"0"	G9	13	"1"	G13
4	"0"	G5	9	"1"	G9	14	"0"	G1
5	"1"	G5	10	"0"	G11			

Figure 8-21 Computer Clock and Bit Timing

# PROJECT GEMINI

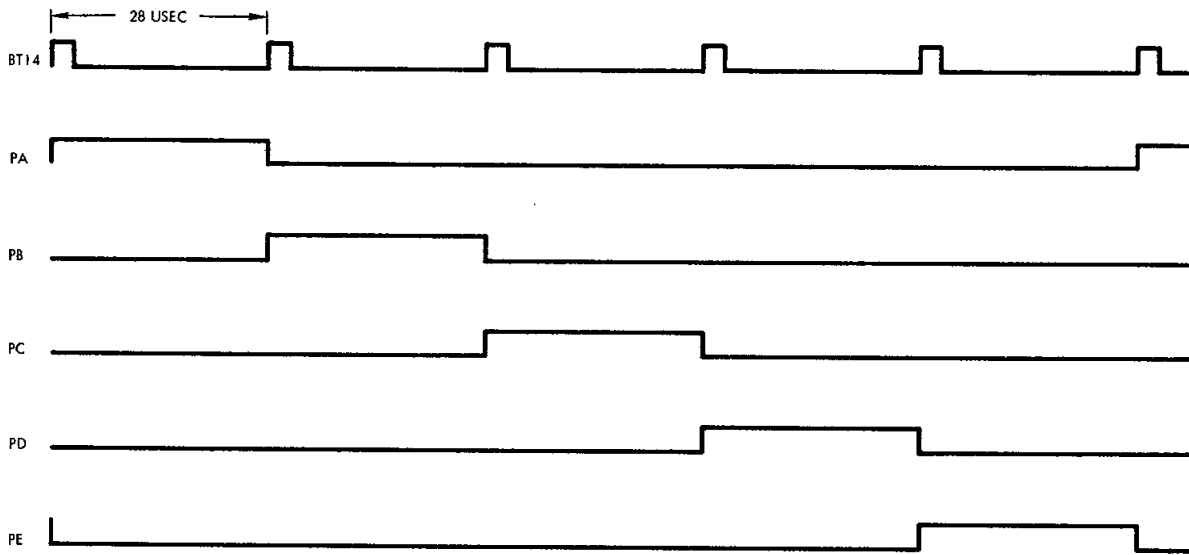
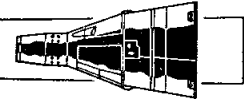

Figure 8-22 Computer Phase Timing

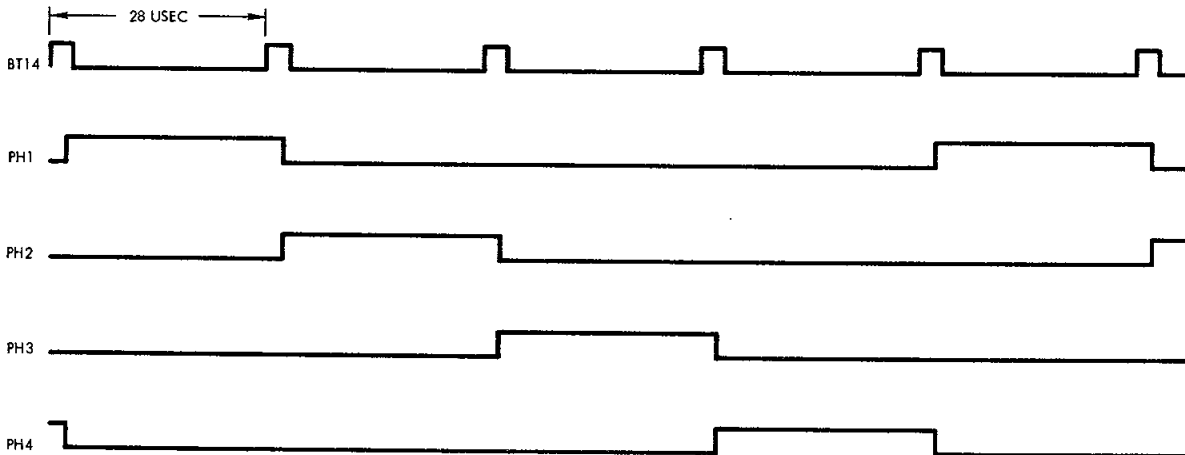

Figure 8-23 Processor Phase Timing



# PROJECT GEMINI



## Memory

The computer memory is a random-access, coincident-current, ferrite array with nondestructive readout. The basic storage element is a two-hole ferrite core. The nondestructive read property makes it possible to read or write serially or in series-parallel, thereby allowing operation with a serial arithmetic unit without a separate buffer register. The memory array can store 4096 words, or 159,744 bits. All memory words of 39 bits are divided into three syllables of 13 bits each. Data words (25 bits and a sign) are normally stored in the first two syllables, and instruction words (13 bits) are intermixed in all three syllables. Once the spacecraft has been removed from the hangar area, it is not possible to modify the third syllable of any memory word. Modification of data stored in syllables 0 and 1 can be accomplished at the launch site through interface with the Manual Data Insertion Unit or the Digital Command System. It can also be accomplished in flight, on spacecraft 8 through 12, using the Auxiliary Tape Memory (ATM).

As shown on Figure 8-24, the memory is a 64 x 64 x 39 bit array of nondestructive readout elements. Physically, it consists of a stack of 39 planes (stacked in the Z dimension), with each plane consisting of a 64 x 64 array of cores. The memory is logically subdivided into smaller parts to increase the program storage efficiency. The Z dimension is divided into three syllables (SYL 0 through SYL 2), with each syllable consisting of 13 bits. The X-Y plane is divided into 16 sectors (SEC 00 through SEC 07, and SEC 10 through SEC 17), with sector 17 being defined as the residual sector.

A memory word is defined as the 39 bits along the Z dimension and is located at one of the 4096 possible X-Y grid positions. An instruction word or command requires 13 bits, and is coded in either syllable 0, 1, or 2 of a memory word. A data word

# PROJECT GEMINI

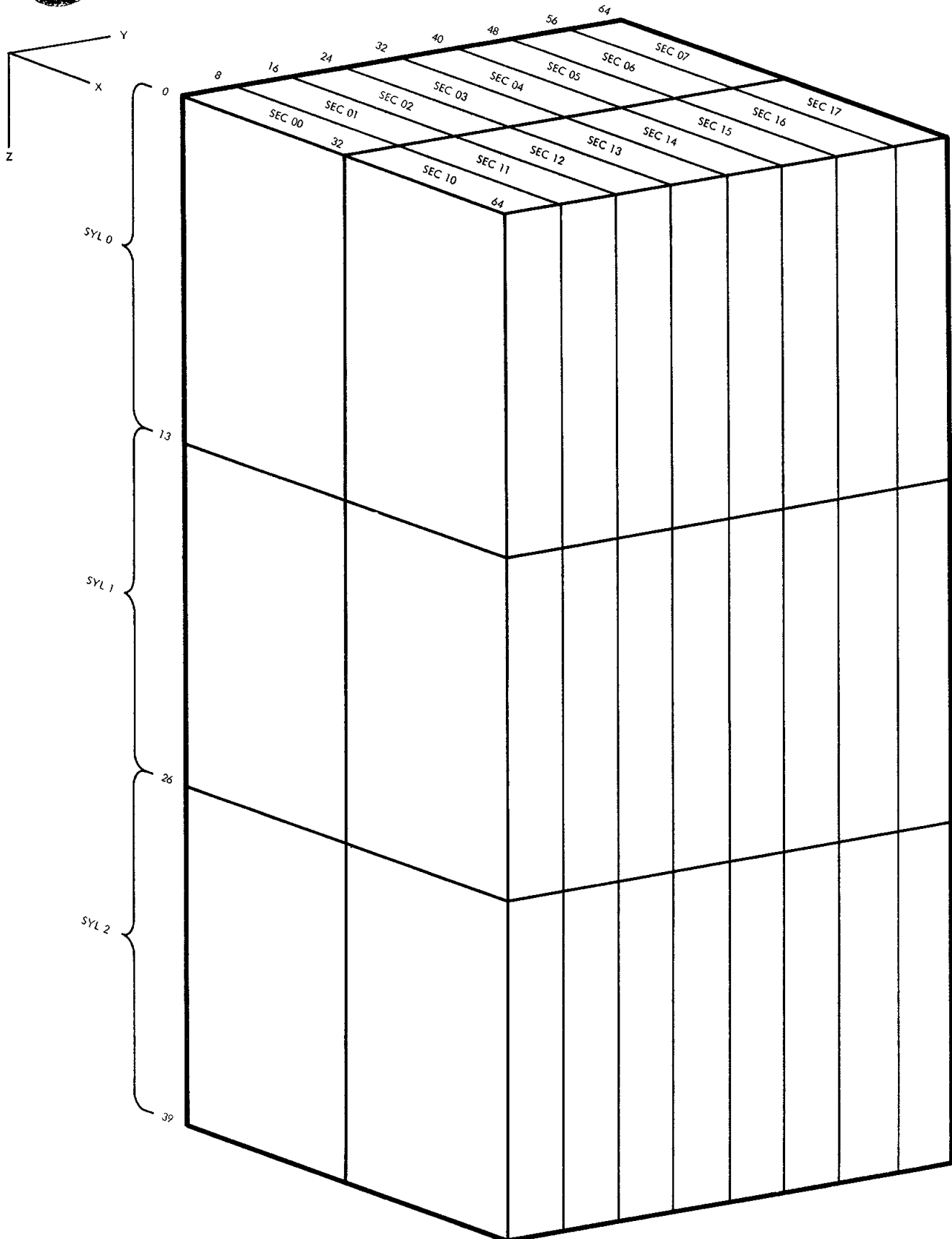
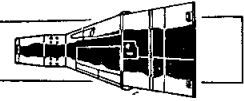

Figure 8-24 Computer Memory Functional Organization



# PROJECT GEMINI



requires 26 bits, and is always coded in syllables 0 and 1 of a memory word. Information stored in syllable 2 can be read as a short data word by using a special mode of operation primarily used to check the contents of the memory.

## NOTE

The operation codes mentioned in the subsequent paragraphs are described in the Instruction and Data Words paragraph.

## Instruction List

The instructions which can be executed by the computer are as follows:

### Operation Code

### Instruction

0000

HOP. The contents of the memory location specified by the operand address are used to change the next instruction address. Four bits identify the next sector, nine bits are transferred to the instruction address counter, two bits are used to condition the syllable register, and one bit is used to select one of the two data word modes.

0001

DIV (divide). The contents of the memory location specified by the operand address are divided by the contents of the accumulator. The 24-bit quotient is available in the quotient delay line during the fifth word time following the DIV.



# PROJECT GEMINI



Operation Code (cont)

Instruction (cont)

- |      |  |
|------|--|
| 0010 | PRO (process input or output). The input or output specified by the operand address is read into, or loaded from, the accumulator. An output command clears the accumulator to zero if address bit A9 is a 1. The accumulator contents are retained if A9 is a 0. (Refer to Table 8-1 for a list of the PRO instructions.) |
| 0011 | RSU (reverse subtract). The contents of the accumulator are subtracted from the contents of the specified memory location. The result is retained in the accumulator.  |
| 0100 | ADD. The contents of the memory location specified by the operand address are added to the contents of the accumulator. The result is retained in the accumulator.   |
| 0101 | SUB (subtract). The contents of the memory location specified by the operand address are subtracted from the contents of the accumulator. The result is retained in the accumulator.   |
| 0110 | CIA (clear and add). The contents of the memory location specified by the operand address are transferred to the accumulator.  |



**PROJECT GEMINI**



Operand Address		Signal
X (Bits A1-A3)	Y (Bits A4-A6)	
0	0	Digital Command System shift pulse gate
0	1	Data Transmission System control gate
0	2	Time Reference System data and timing pulses
0	3	Digit magnitude weight 1
0	4	Reset data ready, enter, and readout
0	5	Digit select weight 1
0	6	Memory strobe
1	0	Computer ready
1	1	Drive counters to zero
1	2	Enter
1	3	Digit magnitude weight 2
1	4	Display device drive
1	5	Digit select weight 2
1	6	Autopilot scale factor
2	0	Pitch resolution
2	1	Select X counter
2	2	Aerospace Ground Equipment data link
2	3	Digit magnitude weight 4
2	5	Digit select weight 4
2	6	Reset start computation

Table 8-1. PRO Instruction Programming (1 of 3)



**PROJECT GEMINI**



Operand Address		Signal
X (Bits A1-A3)	Y (Bits A4-A6)	
3	0	Yaw resolution
3	1	Select Y counter
3	2	Aerospace Ground Equipment data clock
3	3	Digit magnitude weight 8
3	4	Read Manual Data Insertion Unit insert data
3	6	Reset radar ready
4	0	Roll resolution
4	1	Elapsed time control and Time Reference System control reset/ATM wind-rewind Reset
4	3	Computer malfunction
4	4	ATM verify/repro command
4	6	Second stage engine cutoff
5	0	Computer running
5	1	Time to start re-entry calculations control /ATM wind command
5	2	Time to reset control/ATM rewind command
5	3	Write output processor
5	4	Read delta velocity
5	5	Input processor time
5	6	Time to retrofire control
6	3	Read pitch gimbal
6	4	Read roll gimbal

Table 8-1. PRO Instruction Programming (2 of 3)



# PROJECT GEMINI



Operand Address		Signal
X (Bits A1-A3)	Y (Bits A4-A6)	
6	5	Ready yaw gimbal
7	0	Pitch error command
7	1	Yaw error command
7	2	Roll error command

Table 8-1. PRO Instruction Programming (3 of 3)



# PROJECT GEMINI

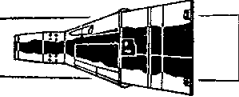

Operation Code (cont)

Instruction (cont)

- |      |  |
|------|--|
| 0111 | AND. The contents of the memory location specified by the operand address are logically ANDed, bit-by-bit, with the contents of the accumulator. The result is retained in the accumulator.  |
| 1000 | MPY (multiply). The contents of the memory location specified by the operand address are multiplied by the contents of the accumulator. The 24 high-order bits of the multiplier and multiplicand are multiplied together to form a 26-bit product which is available in the product delay line during the second word time following the MPY. |
| 1001 | TRA (transfer). The operand address bits (A1 through A9) are transferred to the instruction address counter to form a new instruction address. The syllable and sector remain unchanged.   |
| 1010 | SHF (shift). The contents of the accumulator are shifted left or right, one or two places, as specified by the operand address, according to the following table:  |



PROJECT GEMINI



Operation Code (cont)

Instruction (cont)

	<u>Command</u>	<u>Operand Address</u>	
		<u>X (Bits A1-A3)</u>	<u>Y (Bits A4-A6)</u>
	Shift left one place	*	3
	Shift left two places	*	4
	Shift right one place	1	2
	Shift right two places	0	2
	* Insignificant		
	<p>If an improper address code is given, the accumulator is cleared to zero. While shifting left, 0's are shifted into the low-order positions; while shifting right, the sign bit condition is shifted into the high-order positions.</p>		
1011	<p>TMI (transfer on minus accumulator sign). If the sign is positive (0), the next instruction in sequence is chosen (no branch). If the sign is negative (1), the nine bits of operand address become the next instruction address (perform branch). The syllable and sector remain unchanged.</p>		
1100	<p>STO (store). The contents of the accumulator are stored in the memory location specified by the operand address. The contents of the accumulator are also retained for later use.</p>		



# PROJECT GEMINI



## Operation Code (cont)

## Instruction (cont)

1101

SPQ (store product or quotient). The product is available on the second word time following an MPY. The quotient is available on the fifth word time following a DIV. The product or quotient is stored in the memory location specified by the operand address.

1110

CLD (clear and add discrete). The state of the discrete input selected by the operand address is read into all accumulator bit positions. (Refer to Table 8-2 for a list of the CLD instructions.)

1111

TNZ (transfer on non-zero). If the contents of the accumulator are zero, the next instruction in sequence is chosen (no branch); if the contents are non-zero, the nine bits of operand address become the next instruction address (perform branch). The syllable and sector remain unchanged.

### NOTE

The instructions mentioned in the subsequent paragraphs (e.g., HOP, TRA, TMI, and TNZ) are described more completely in the Instruction Information Flow paragraph.

## Instruction Sequencing

The instruction address is derived from an instruction counter and its associated



**PROJECT GEMINI**



Operand Address		Signal
X (Bits A1-A3)	Y (Bits A4-A6)	
0	0	Radar ready
0	1	Computer mode 2
0	2	Spare
0	3	Processor timing phase 1
0	4	Spare
1	0	Data ready
1	1	Computer mode 1
1	2	Start computation
1	3	X zero indication
1	4	ATM clock
2	0	Enter
2	1	Instrumentation System sync
2	2	Velocity error count not zero
2	3	Aerospace Ground Equipment request
2	4	Spare
3	0	Readout
3	1	Computer mode 3
3	2	Spare
3	3	ATM on
3	4	ATM data channel 2
4	0	Clear

Table 8-2. CLD Instruction Programming (1 of 2)



**PROJECT GEMINI**



Operand Address		Signal
X (Bits A1-A3)	Y (Bits A4-A6)	
4	1	ATM mode control 1
4	2	Simulation mode command
4	3	ATM end of tape
4	4	ATM data channel 3
5	0	Time to start re-entry calculations
5	1	ATM mode control 2
5	2	Y zero indication
5	3	ATM data 1
5	4	Spare
6	0	Digital Command System ready
6	1	Fade-in discrete
6	2	Z zero indication
6	3	Umbilical disconnect
6	4	Spare
7	0	Instrumentation System request
7	1	Abort transfer
7	2	Aerospace Ground Equipment input data
7	3	Spare
7	4	Spare

Table 8-2. CLD Instruction Programming (2 of 2)



**PROJECT GEMINI**



address register. To address an instruction, the syllable, sector, and word position within the sector (one of 256 positions) must be defined. The syllable and sector are defined by the contents of the syllable register (two-bit code, three combinations) and sector register (four-bit code, 16 combinations). These registers can be changed only by a HOP instruction. The word position within the sector is defined by the instruction address counter. The instruction address count is stored serially in a delay line; and normally each time it is used to address a new instruction, a one is added to it so that the instruction locations within a sector can be sequentially scanned. The number stored in the counter can be changed by either a TRA, TMI, or TNZ instruction, with the operand address specifying the new number. A HOP instruction can also change the count, with the new instruction location coming from a data word.

Instruction and Data Words

The instruction word consists of 13 bits and can be coded in any syllable of any memory word. The word is coded as follows:

<u>Bit Position</u>	1	2	3	4	5	6	7	8	9	10	11	12	13
<u>Bit Code</u>	A1	A2	A3	A4	A5	A6	A7	A8	A9	OP1	OP2	OP3	OP4

The four operation bits (OP1 through OP4) define one of 16 instructions, the eight operand address bits (A1 through A8) define a memory word within the sector being presently used, and the residual bit (A9) determines whether or not to read the data residual. If the A9 bit is a 1, the data word addressed is always located in the last sector (sector 17). If the A9 bit is a 0, the data word addressed is read from the sector defined by the contents of the sector register. This feature allows data locations to be available to instructions stored anywhere in the



**PROJECT GEMINI**



memory .

The data word consists of 25 magnitude bits and a sign bit. Numbers are represented in two's-complement form, with the low-order bits occurring at the beginning of the word and the sign bit occurring after the highest-order bit. The binary point is placed between bit positions 25 and 26. The bit magnitude number also denotes the binary weight of the position. For example, M16 represents  $2^{-16}$ .

For the HOP instruction, the next instruction address is coded in a data word that is read from the memory location specified by the operand address of the HOP word.

The codings of a numerical data word and a HOP word are as follows:

<u>Bit Position</u>	1	2	3	4	5	6	7	8	9	10	11	12	13
<u>Data Word</u>	M25	M24	M23	M22	M21	M20	M19	M18	M17	M16	M15	M14	M13
<u>HOP Word</u>	A1	A2	A3	A4	A5	A6	A7	A8	A9	S1	S2	S3	S4
<u>Bit Position</u>	14	15	16	17	18	19	20	21	22	23	24	25	26
<u>Data Word</u>	M12	M11	M10	M9	M8	M7	M6	M5	M4	M3	M2	M1	S
<u>HOP Word</u>	-	SYA	SYB	-	S5	-	-	-	-	-	-	-	-

For the HOP word, eight address bits (A1 through A8) select the next instruction (one of 256) within the new sector, the residual bit (A9) determines whether or not the next instruction is located in the residual sector, the sector bits (S1 through S4) select the new sector, and the syllable bits (SYA and SYB) select the new syllable according to the following table:

<u>Syllable</u>	<u>SYB</u>	<u>SYA</u>
0	0	0
1	0	1
2	1	0



# PROJECT GEMINI



The special syllable bit (S5) determines the mode in which data words are to be read. If the S5 bit is a 0, normal operation of reading data words from syllables 0 and 1 is followed; however, if the S5 bit is a 1, data words are read from syllable 2 only. These data words contain information from syllable 2 in bit positions 1 through 13, but contain all 0's in bit positions 14 through 26. This special mode is followed until a new HOP command places the computer back in the normal mode of reading data words. (While in the special mode, any HOP word addressed always has 0's coded in the SYA, SYB, and S5 positions due to the short data word that is read; therefore, any HOP word coded while in this mode terminates the mode and operation is resumed in syllable 0.) The computer itself does not have the capability to store information in syllable 2; therefore, STO and SPQ commands are not executed while in the special mode. The mode is used only to allow the computer arithmetic circuits to check the entire memory contents to verify the fact that the proper information is in storage.

In a HOP word, the residual bit (A9) overrides the sector bits (S1 through S4). If the A9 bit is a 1, the next instruction is read from the residual sector. If, however, the A9 bit is a 0, the S1 through S4 bits determine the sector from which the next instruction is read.

For convenience, the data and instruction words can be coded in an octal form that is easily converted to the machine binary representation. The order in which the bits are written is reversed to conform to the normal method of placing lower-significance bits to the left so that, while performing arithmetic, the low-order bits are accessed first.) The coding structure is as follows:





## PROJECT GEMINI

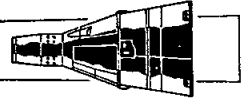

obtain the answer at the proper time since the multiply-divide element has no means of completing an operation by itself. When an MPY is commanded, the product is obtainable from the multiply-divide element two cycle times later by an SPQ instruction. When a DIV is commanded, the quotient is obtainable five cycle times later by an SPQ instruction.

It is possible to have one other instruction run concurrently between the MPY and the SPQ during multiply, and four other instructions run concurrently between the DIV and the SPQ during divide. However, an MPY or a DIV is always followed with an SPQ before a new MPY or DIV is given.

### Basic Information Flow

Refer to Figure 8-25 for the following description of information flow during the five computer phase times. The description is limited to those operations requiring only one cycle time, and thus does not pertain to MPY and DIV.

During phase A, the 13-bit instruction word is read from memory and stored in the instruction address register. The address of the instruction is defined by the contents of the memory address register, the sector register, and the syllable register. The four operation code bits (OP<sup>1</sup> through OP<sup>4</sup>) are stored in the operation register. During phase B, the operand address bits (A<sup>1</sup> through A<sup>8</sup>) are serially transferred from the instruction address register to the memory address register. Simultaneously, the instruction address stored in the memory address register is incremented by plus one and stored in the instruction address register. The operation specified by the operation code bits is performed during phases C and D. During phase E, the next instruction address stored in the instruction address register is transferred to the memory address register.

# PROJECT GEMINI

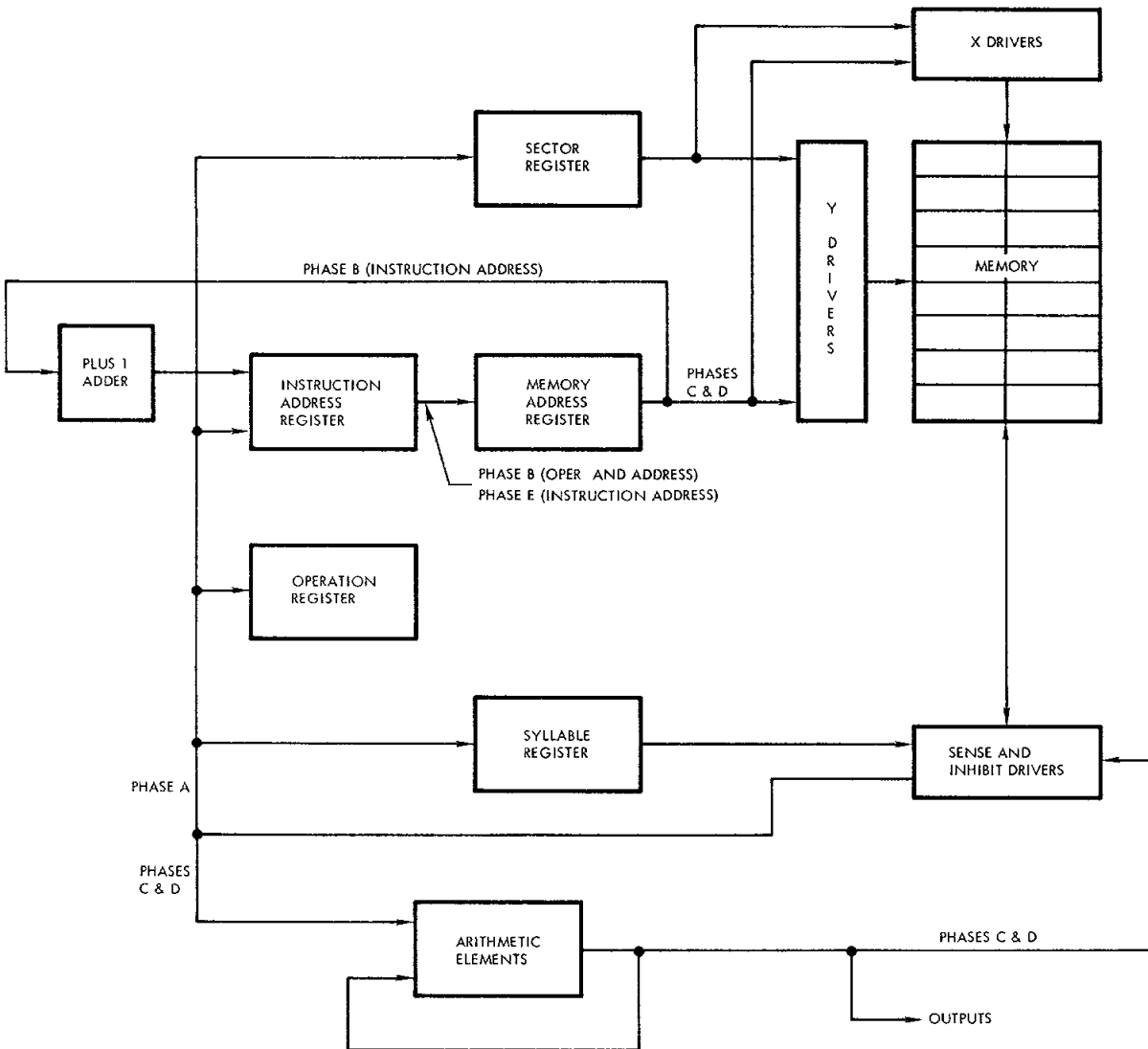

Figure 8-25 Basic Information Flow



# PROJECT GEMINI



Four of the one-cycle operations do not strictly adhere to the above information flow. These operations are HOP, TRA, TMI, and TNZ. For the HOP instruction, data read from memory during phases C and D is transferred directly to the instruction address register, the sector register, and the syllable register. For the TRA, TMI, and TNZ operations, the transfer of the next instruction address from the instruction address register during phase E is inhibited to allow the operand address to become the next instruction address.

## Instruction Information Flow

Flow Diagram: The instruction information flow diagram (Figure 8-26) should be used along with the following descriptions.

### CIA Operation

During phases C and D, the data that was contained in the accumulator during phases A and B is destroyed. Simultaneously, new data from the selected memory location is transferred through the sense amplifiers and into the accumulator. During phases E and A, the new data is recirculated so as to be available in the accumulator during phases A and B.

### ADD Operation

During phases C and D, new data from the selected memory location is transferred through the sense amplifiers and into the accumulator. Here, the new data is added to the data that was contained in the accumulator during phases A and B. During phases E and A, the sum data is recirculated so as to be available in the accumulator during phases A and B.

### SUB Operation

During phases C and D, new data from the selected memory location is transferred

PROJECT GEMINI

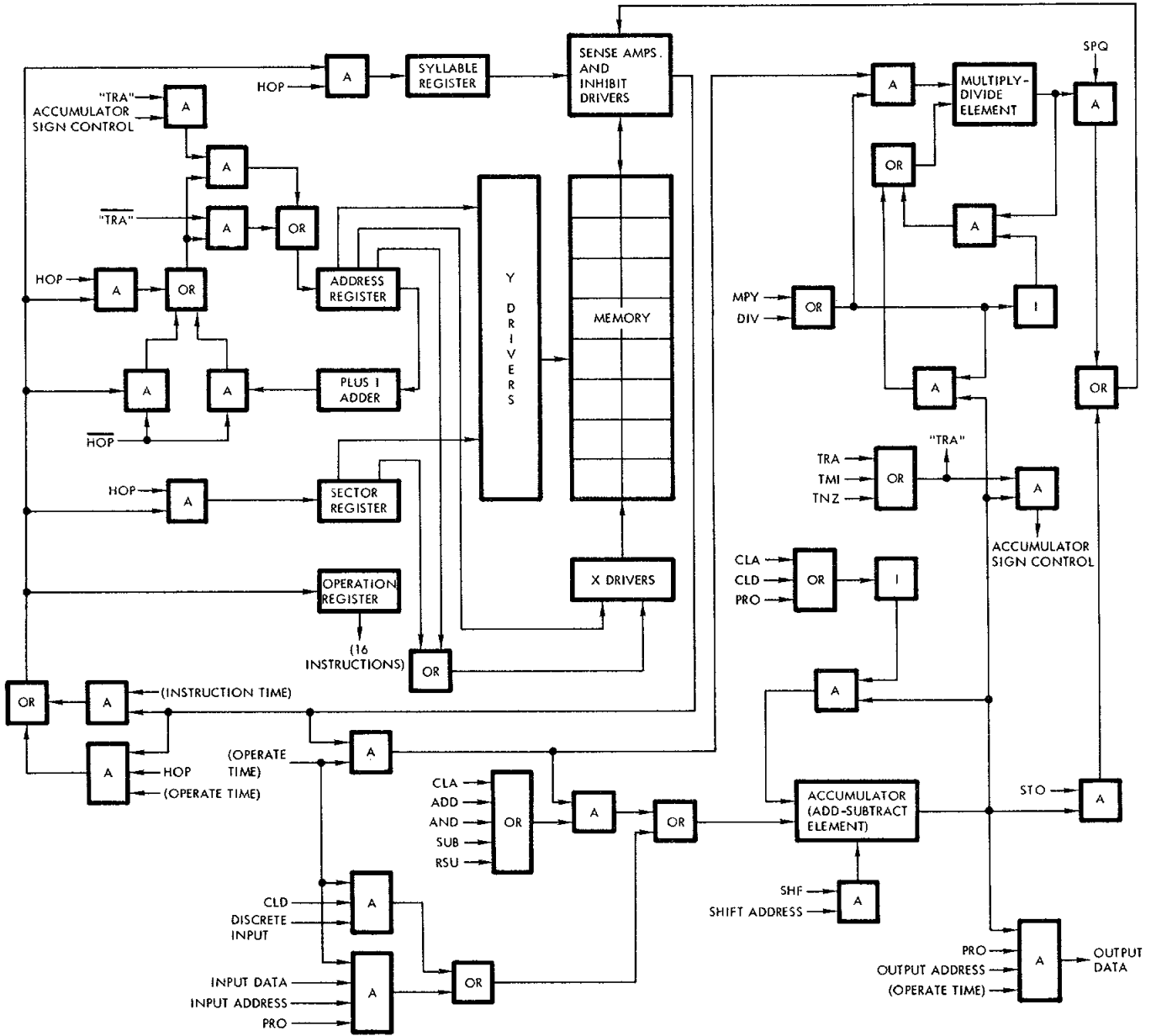
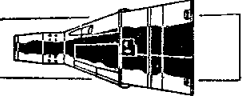

**NOTE**

A = AND; I = INVERTER

Figure 8-26 Instruction Information Flow



# PROJECT GEMINI

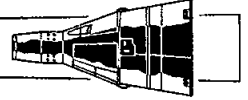

through the sense amplifiers and into the accumulator. Here, the new data is subtracted from the data that was contained in the accumulator during phases A and B. During phases E and A, the difference data is recirculated so as to be available in the accumulator during phases A and B.

## RSU Operation

During phases C and D, new data from the selected memory location is transferred through the sense amplifiers and into the accumulator. Here, the data that was contained in the accumulator during phases A and B is subtracted from the new data. During phases E and A, the difference data is recirculated so as to be available in the accumulator during phases A and B.

## AND Operation

During phases C and D, new data from the selected memory location is transferred through the sense amplifiers and into the accumulator. Here, the new data is ANDed with the data that was contained in the accumulator during phases A and B. During phases E and A, the ANDed data is recirculated so as to be available in the accumulator during phases A and B.

## SHF Operation

During phases C and D, the data that was contained in the accumulator during phases A and B is shifted left or right, one or two places, as specified by the operand address. During phases E and A, the shifted data is recirculated so as to be available in the accumulator during phases A and B.

## STO Operation

During phases C and D, the data that was contained in the accumulator during phases A and B is transferred through the inhibit drivers and stored in the memory



# PROJECT GEMINI



location selected by the operand address. During phases E and A, the same data is recirculated so as to be available in the accumulator during phases A and B.

## ROP Operation

During phases C and D, new data from the selected memory location is transferred through the sense amplifiers and into the address, sector, and syllable registers. Here, the new data is used to select the address, sector, and syllable of the memory location from which the next instruction will be read.

## TRA Operation

During phases A and B, the instruction from the selected memory location is transferred through the sense amplifiers and into the address register. Here, the instruction is used to select the address of the memory location from which the next instruction will be read. The sector and syllable remain unchanged.

## TMI Operation

During phases A and B, the instruction from the selected memory location is transferred through the sense amplifiers and into the address register. Here, if the accumulator sign is negative, the instruction is used to select the address of the memory location from which the next instruction will be read. However, if the accumulator sign is positive, the next instruction address in sequence is selected in the normal manner. The sector and syllable remain unchanged.

## TNZ Operation

During phases A and B, the instruction from the selected memory location is transferred through the sense amplifiers and into the address register. Here, if the contents of the accumulator are not zero, the instruction is used to select the address of the memory location from which the next instruction will be read.



# PROJECT GEMINI



However, if the contents of the accumulator are zero, the next instruction address in sequence is selected in the normal manner. The sector and syllable remain unchanged.

## CLD Operation

During phases C and D, the data that was contained in the accumulator during phases A and B is destroyed. Simultaneously, the state of the discrete input selected by the operand address is transferred into all accumulator bit positions. During phases E and A, the new data is recirculated so as to be available in the accumulator during phases A and B.

## PRO Operation (Inputs; when A9=1)

During phases C and D, the data that was contained in the accumulator during phases A and B is destroyed. Simultaneously, the data on the input channel selected by the operand address is transferred into the accumulator. During phases E and A, the new data is recirculated so as to be available in the accumulator during phases A and B.

## PRO Operation (Inputs; when A9=0)

During phases C and D, the data on the input channel selected by the operand is transferred into the accumulator. Here, the new data is ORed with the data that was contained in the accumulator during phases A and B. During phases E and A, the ORed data is recirculated so as to be available in the accumulator during phases A and B.

## PRO Operation (Outputs)

During phases C and D, the data that was contained in the accumulator during phases A and B is transferred to the output channel selected by the operand address. If



# PROJECT GEMINI

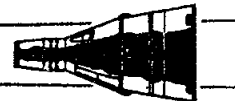

the A9 bit of the operand address is a 1, the data that was contained in the accumulator during phases A and B is then destroyed. However, if the A9 bit is a 0, the data is recirculated so as to be available in the accumulator during phases A and B.

## MPY Operation

During phases A and B of the first instruction cycle, the data that is contained in the accumulator is transferred into the multiply-divide element as the multiplier. During phases C and D of the same cycle, new data from the selected memory location is transferred through the sense amplifiers and into the multiply-divide element as the multiplicand. During the remainder of the first instruction cycle and the next two instruction cycles, the multiplicand is multiplied by the multiplier. The product is available in the multiply-divide element during phases C and D of the third instruction cycle.

## DIV Operation

During phases A and B of the first instruction cycle, the data that is contained in the accumulator is transferred into the multiply-divide element as the divisor. During phases C and D of the same cycle, new data from the selected memory address is transferred through the sense amplifiers and into the multiply-divide element as the dividend. During the remainder of the first instruction cycle and the next five instruction cycles, the dividend is divided by the divisor. The quotient is available in the multiply-divide element during phases C and D of the sixth instruction cycle.



# PROJECT GEMINI



## SPQ Operation

During phases C and D, the product or quotient that is contained in the multiply-divide element is transferred through the inhibit drivers and stored in the memory location selected by the operand address.

### NOTE

In the subsequent program and interface descriptions, the signals that are programmed by CLD and PRO instructions are sometimes referred to as DI (Discrete Input) or DO (Discrete Output) signals. The two digits following the DI or DO are the Y and X addresses, respectively, of the instructions.

## OPERATIONAL PROGRAM

### General

Two different programs are used with the rendezvous configuration of the spacecraft. For spacecraft 6, the sixth operational program is utilized. For spacecraft 8 and up, the seventh operational program is used. The primary difference between the two is that the latter is a modular program and is used in conjunction with the Auxiliary Tape Memory (ATM).

### Sixth Operational Program

The sixth operational program consists of six basic routines, called executor, pre-launch, ascent, catch-up, rendezvous, and re-entry. Each routine is made up of several subroutines. Some of the subroutines are common to all routines while



# PROJECT GEMINI



some are unique to a particular routine. Each subroutine consists of a series of program instructions which, when executed, cause specific computer circuits to operate. The initiation of a particular routine is controlled by the COMPUTER mode switch on the Pilots' Control and Display Panel. Once a routine is initiated, the subroutines within the routine are executed automatically.

## Executor Routine

The executor routine selects, and handles the functions common to, all other routines. The program flow for this routine is shown on Figure 8-27. The individual blocks shown on the figure are explained as follows:

- (a) Block 1. When the computer is turned on, the first memory location addressed is address 000, sector 00, syllable 0. This memory location is the first memory address utilized by the executor routine.
- (b) Block 2. The operational program utilizes special predetermined memory locations which are designed as Logical Choice (LC) addresses. At certain times, the sign bits at these LC addresses are set minus (1) or plus (0). The sign bits of specific LC addresses are then checked during the execution of the routines and, depending on whether they are plus or minus, special series of program instructions are executed.
- (c) Block 3. The following discrete outputs are set plus: start computation, computer running, second stage engine cutoff, auto-pilot scale factor, AGE data clock, and Time Reference System gate.

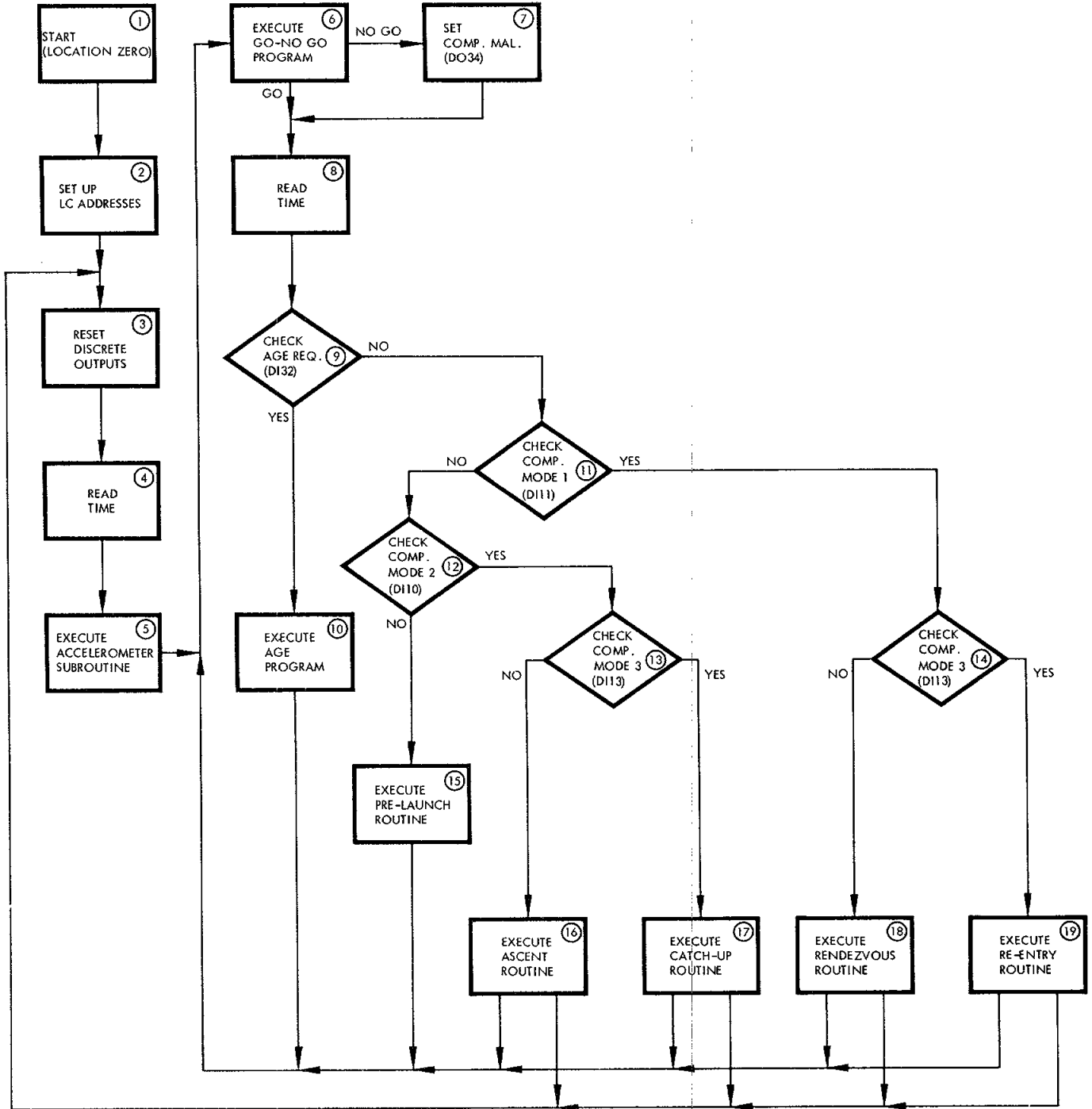
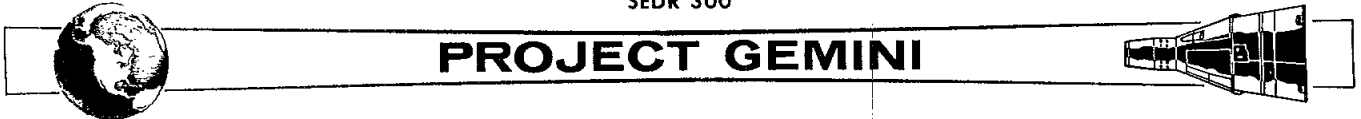
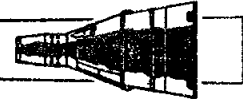

Figure 8-27 Executor Routine Program Flow



# PROJECT GEMINI



- (d) Block 4. The processor real time count is read for utilization by the individual routines.
- (e) Block 5. The accelerometer subroutine is executed to verify that the X, Y and Z velocity signals from the accelerometers equal zero.
- (f) Block 6. A special go, no-go diagnostic program is executed to determine if the basic computer arithmetic circuits are functioning properly. If these circuits fail, the NO GO path is followed; if there is no failure, the GO path is followed.
- (g) Block 7. Program instruction PR034 is executed. The execution of this instruction causes the computer malfunction circuit to be conditioned.
- (h) Block 8. The processor real time count is read and updated for utilization by the individual routines.
- (i) Block 9. Program instruction CLD32 is executed to determine the condition of the AGE request discrete input. If the input is a 1, the YES path is followed; if the input is a 0, the NO path is followed.
- (j) Block 10. Special check-out tests are executed by the AGE. Both the Gemini Launch Vehicle and the computer can be checked out.
- (k) Blocks 11 through 14. Program instructions CLD10, CLD11, and CLD13 determine the condition of the discrete inputs from the COMPUTER mode switch. This switch is manually controlled by the pilot and,



# PROJECT GEMINI



depending upon which mode is selected, causes a particular routine to be executed until the switch setting is changed or until the computer is turned off. The combinations of COMPUTER mode switch discrete inputs required to select a particular routine are as follows:

<u>Routine</u>	<u>Discrete Inputs</u>		
	<u>D110</u>	<u>D111</u>	<u>D113</u>
Pre-launch	0	0	0
Ascent	1	0	0
Catch-up	1	0	1
Rendezvous	0	1	0
Re-entry	0	1	1

- (1) Blocks 15 through 19. Depending on the setting of the COMPUTER mode switch, one of these operational routines is selected. The individual routines are discussed in subsequent paragraphs.

## Pre-launch Routine

The pre-launch routine provides the instructions required to check out the computer prior to launch and to read in special data for future use. This routine performs sum-checks on all sectors within the computer memory. These checks are performed by adding the contents of all memory addresses within a sector and comparing the sum with a pre-stored constant. If the constant and the sum are not equal, the computer malfunction latch is set by program instruction PRO34. If the sum check is successful, special data is stored in predetermined memory addresses by the common subroutines. These subroutines are discussed in later paragraphs.



# PROJECT GEMINI



## Ascent Routine

The ascent routine provides the computations required for back-up ascent guidance. After the computer has been placed in the ascent mode, special data is transferred to the computer via the Digital Command System. This data is then continually updated and used to keep track of the orbit plane and the platform attitude with respect to Earth. Thirty seconds after the special data is first transferred to the computer, the Inertial Guidance System is placed in the inertial mode. The computer continually monitors and stores the platform gimbal angle values during this time. After lift-off, the computer performs a back-up guidance function. If necessary, however, the computer can be used to perform primary guidance during ascent.

## Catch-up Routine

The catch-up routine provides the computations required to properly position the spacecraft for rendezvousing. During the catch-up mode, gimbal angle values and incremental velocity values are computed. Calculated data is then supplied to the Attitude Display so that the spacecraft can be properly positioned for rendezvousing.

## Rendezvous Routine

The rendezvous routine provides the computations required for achieving a rendezvous. The routine performs essentially the same function as the catch-up routine, with the addition of radar data computations. The radar data is transferred to the computer from the rendezvous radar and utilized in computations. These computations are used to achieve a rendezvous between the spacecraft and the target.

## Re-entry Routine

The re-entry routine provides the computations required for re-entry guidance.



# PROJECT GEMINI



During the re-entry mode, the retrograde velocity is monitored and retrograde velocity errors are calculated. The distance and heading of the spacecraft with respect to the desired landing site are calculated, and the down range travel to touchdown is predicted. The routine also provides signals to command the spacecraft roll maneuvers during re-entry and provides a display of attitude errors.

## NOTE

The following subroutines are common to the previously described routines: gimbal angle, accelerometer, Digital Command System, Instrumentation System, and manual data. Therefore, a description of each of these subroutines follows.

### Gimbal Angle Subroutine

The gimbal angle subroutine reads and processes the gimbal angles for the pitch, yaw, and roll axes of the Inertial Platform. During a computer word time, the gimbal angle processor reads in one gimbal angle value and transfers a previously read gimbal angle value to the accumulator. This method enables a faster processing operation than if the angle for each axis were processed, individually. Approximately 5 ms elapses between the processing of one gimbal angle value and the processing of the next gimbal angle value. (The gimbal angle value is the binary equivalent of the actual gimbal angle.)

### Accelerometer Subroutine

The accelerometer subroutine processes velocity signal inputs from the Inertial Measuring Unit. These signals, which represent velocity for the X, Y, and Z axes of the spacecraft, are generated by accelerometers. Due to the construction and adjustment of the accelerometers, the signals contain inherent bias and alignment



# PROJECT GEMINI



errors. The subroutine corrects these errors and stores the corrected velocity values in predetermined computer memory locations. The computer input processor reads the X, Y, and Z velocity signals, and transfers them to the processor delay line. The delay line is then read by the subroutine at periodic intervals which depend on the selected mode or routine.

## Digital Command System Subroutine

The Digital Command System subroutine reads and processes data furnished by the Digital Command System (DCS). The DCS furnishes the computer with special 24-bit words consisting of 6 address bits and 18 data bits. The address bits indicate where the data bits are to be stored in the computer memory. The subroutine first determines if data is available from the DCS. If data is available, the subroutine then reads the data into the accumulator. Next, the address and data bits are separated. The data bits are then stored in the computer memory address specified by the address bits. After this data is stored, it is used as constants by other subroutines.

The DCS subroutine also contains instructions which provide extended DCS addresses. (Address 100-117). The recognition of addresses 20 and 21 exercises the proper operational program loops to store the data in the computer. For each DCS extended address insert, it is necessary to make two transmissions and this must be accomplished in the proper order (i.e., DCS address 20 first, 21 next). On the first cycle through the DCS subroutine, address 20 is recognized and the associated data is stored as high order data. On the second cycle, address 21 is recognized and the associated data yields low order data plus the DCS extended address word. With the DCS extended address, it is possible to insert 26-bit words into the computer.



# PROJECT GEMINI



## Instrumentation System Subroutine

The Instrumentation System subroutine assembles special data and transfers it to the Instrumentation System. Every 2.4 seconds, 21 data words are transferred to the Instrumentation System by the subroutine. The transferred data words are the stored results of other subroutines. The types of data words transferred include velocity changes for the X, Y, and Z axes, gimbals angle values for the pitch, roll, and yaw axes, and radar range. Once every 2.4 seconds, the Instrumentation System sync discrete input occurs. When the input occurs, the data words to be transferred are assembled in a special Instrumentation System memory buffer. The buffer consists of 21 predetermined memory addresses. A special memory address is used as a word selection counter to determine which data words in the Instrumentation System memory buffer are to be transferred to the Instrumentation System.

## Manual Data Subroutine

The manual data subroutine determines when data is transferred from the Manual Data Keyboard (MDK) to the computer and from the computer to the Manual Data Readout (MDR). The subroutine consists of approximately 1000 instructions which are used to govern the generation of signals that control circuit operation in the MDK and MDR.

## Seventh Operational Program

The seventh operational program consists of six modules. At this time, spacecraft 8 and 9 are scheduled to use modules I, IV and V. Spacecraft 10 is scheduled to use all six modules. Each module contains certain routines and subroutines as discussed below and under Sixth Operational Program.

### Module I

Module I represents that portion of the program which is always maintained in



# PROJECT GEMINI



the computer memory. It contains the programming required for the pre-launch mode as well as that associated with the executer functions, diagnostic sub-routines, computational subroutines and the ATM read programs.

## Module II

Module II consists of the ascent computer mode, a simplified catch-up mode (no radar interface) and that portion of the re-entry mode required for ascent/abort re-entry guidance. For ascent/abort re-entry, the computer mode selector remains in ASC.

## Module III

Module III consists of the catch-up and rendezvous modes as described under Sixth Operational Program.

## Module IV

Module IV contains the touchdown predict and re-entry modes. The touchdown predict mode provides an on-board capability for predicting the half-lift touchdown point on the basis of ground-computed orbital initial condition data and a selected trial retrograde time. The calculated time-to-go to retrograde and the associated retrograde initial conditions may be automatically transferred to the Time Reference System (TRS) and re-entry program, respectively, for subsequent initialization of the re-entry mode. The re-entry mode is generally the same as that described for the Sixth Operational Program.

## Module V

Module V contains the ascent mode of module II, without the ascent/abort capability, and the catch-up and rendezvous modes of module III without the rendezvous self test. The purpose of module V is to insure that ATM load failure



# PROJECT GEMINI



will not jeopardize completion of rendezvous mission objectives.

## Module VI

Module VI contains the orbit predict, orbit navigation, and orbit determination modes.

The orbit predict mode provides the capability to calculate the velocity and position of the spacecraft or target vehicle (or their relative velocity and position) as much as three orbits into the future or one orbit into the past. This mode also provides the capability to simulate impulsive velocity changes in the spacecraft orbit. This is accomplished by accepting velocity change inputs in the guidance axes while the orbit computation is not in progress.

The orbit navigation mode provides the means to navigate the spacecraft during velocity and position changes by including the accelerometer outputs in the computer equations of motion.

The orbit determination mode provides the capability to improve the on-board navigation accuracy by processing the measurements of star to horizon angle or star to local verticle angle taken aboard the spacecraft.

## INTERFACES

Figure 8-28 shows the equipment which interfaces with the computer. The diagram also contains references to the individual equipment interface diagrams.

### Inertial Platform (Figure 8-29)

The computer supplies 400 cps excitation to the rotors of three resolvers located on the pitch, roll, and yaw gimbal axes of the Inertial Platform. Movement of the rotors of any of these resolvers away from their zero (platform-caged) reference

# PROJECT GEMINI

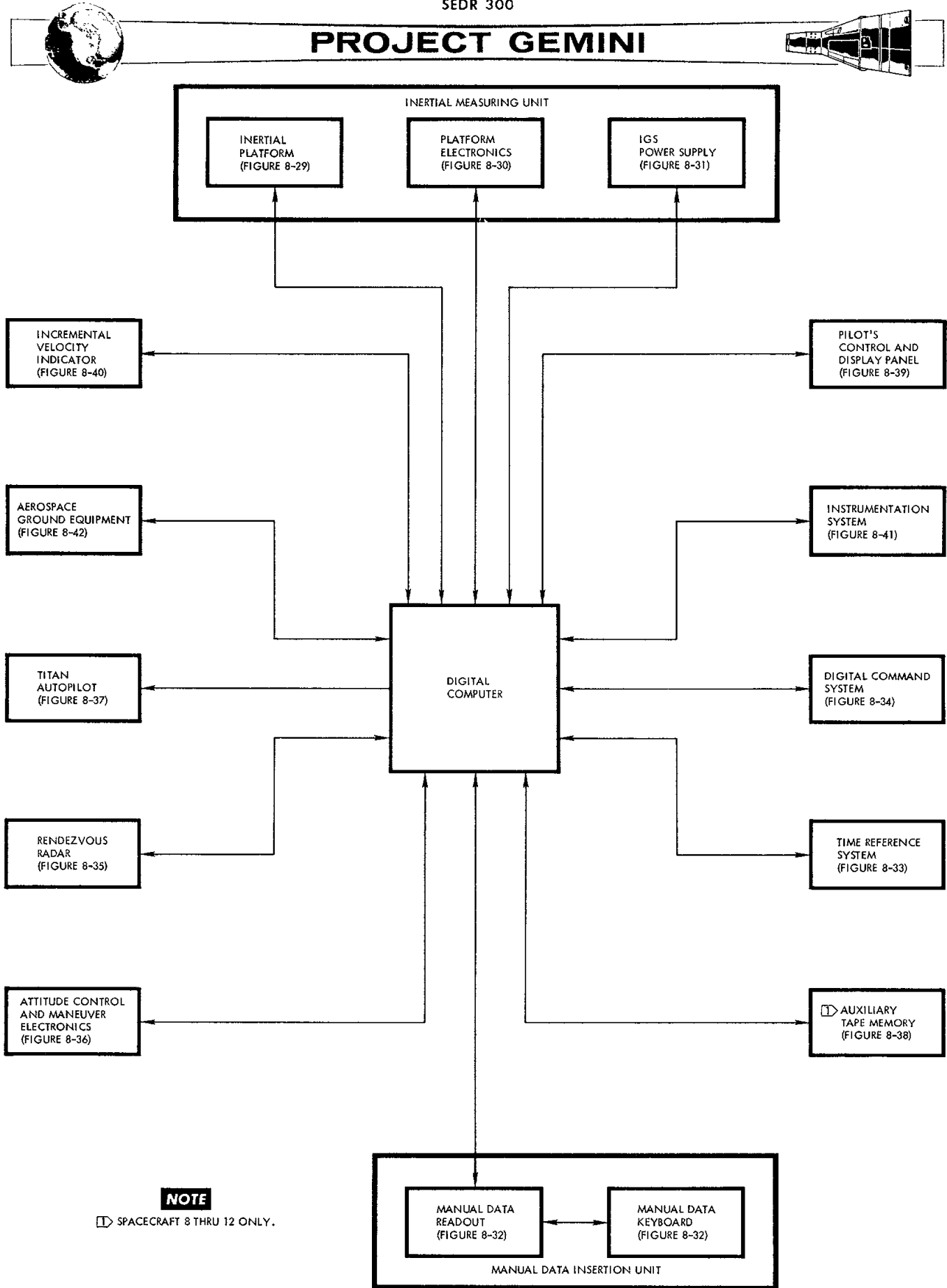

**NOTE**  
▷ SPACECRAFT 8 THRU 12 ONLY.

Figure 8-28 Computer Interfaces

# PROJECT GEMINI

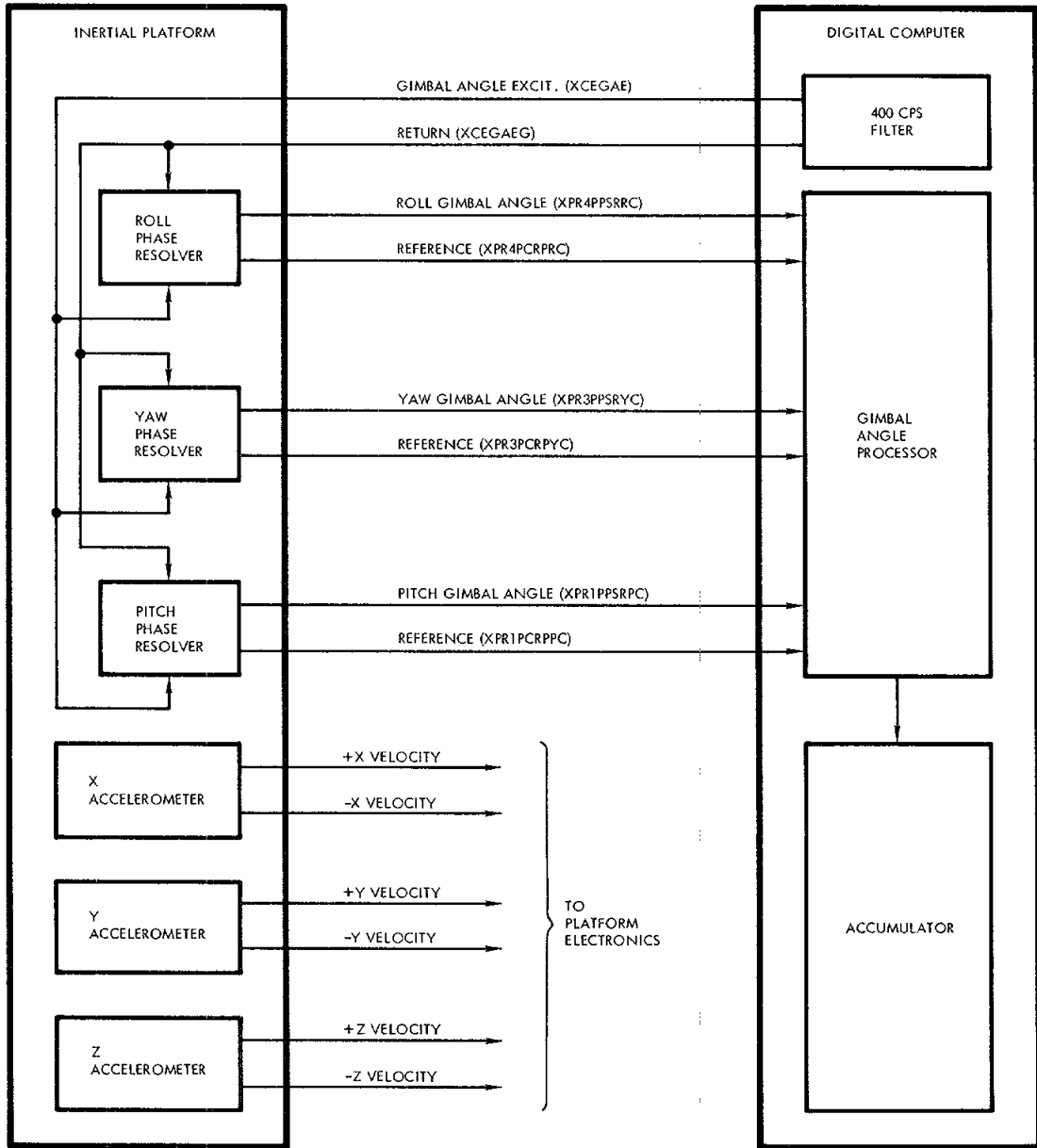

Figure 8-29 Computer-Platform Interface



# PROJECT GEMINI



causes the output voltage of the stator winding to be phase-shifted relative to the reference 400 cps voltage inputs to the computer: a reference voltage from the compensator winding (pitch, yaw, and roll references), and a phase-shifted voltage from the stator winding (pitch, yaw, and roll gimbal angles).

The following PRO instruction programming is associated with the Inertial Platform interface:

<u>Signal</u>	<u>Address</u>	
	<u>X</u>	<u>Y</u>
Read pitch gimbal	6	3
Read roll gimbal	6	4
Read yaw gimbal	6	5

The gimbal angles are read no sooner than 5 ms from each other, and the total reading time for all three angles is no greater than 30 ms. The angles are read once per computation in the catch-up, rendezvous, and re-entry modes, and once every 50 ms in the ascent mode. These angles are gated, as true magnitude, into the accumulator S, and 1 through 14 bit positions with the 15 through 25 bit positions being zero. The accumulator value from the first PRO instruction is discarded. Each of the next three PRO instructions results in an accumulator value of the gimbal angle read by the previous PRO instruction, as follows:

- (a) PRO36 (read pitch; process previously read angle)
- (b) Discard previously read angle
- (c) Wait 5 ms
- (d) PRO46 (read roll; process pitch)
- (e) STO pitch



# PROJECT GEMINI



- (f) Wait 5 ms
- (g) PRO56 (read yaw; process roll)
- (h) STO roll
- (i) Wait 5 ms
- (j) PRO36 (read pitch; process yaw)
- (k) STO yaw

The computer inputs from the Inertial Platform are summarized as follows:

- (a) Roll gimbal angle (XPR4PPSRRC) and reference (XPR4PCRPRC)
- (b) Yaw gimbal angle (XPR3PPSRYC) and reference ((XPR3PCRPYC)
- (c) Pitch gimbal angle (XPRLPPSRPC) and reference (XPRLPCRPPC)

The computer output to the Inertial Platform is summarized as follows:

Gimbal angle excitation (XCEGAE) and return (XCEGAEG)

## System Electronics (Figure 8-30)

Outputs derived from each of the three platform accelerometers are supplied to the computer as incremental velocity pulses (+X and -X delta velocity, +Y and -Y delta velocity, and +Z and -Z delta velocity). An up level on one line denotes a positive increment of velocity while an up level on the other line denotes a negative increment of velocity.

The following PRO instruction programming is associated with the System Electronics interface:

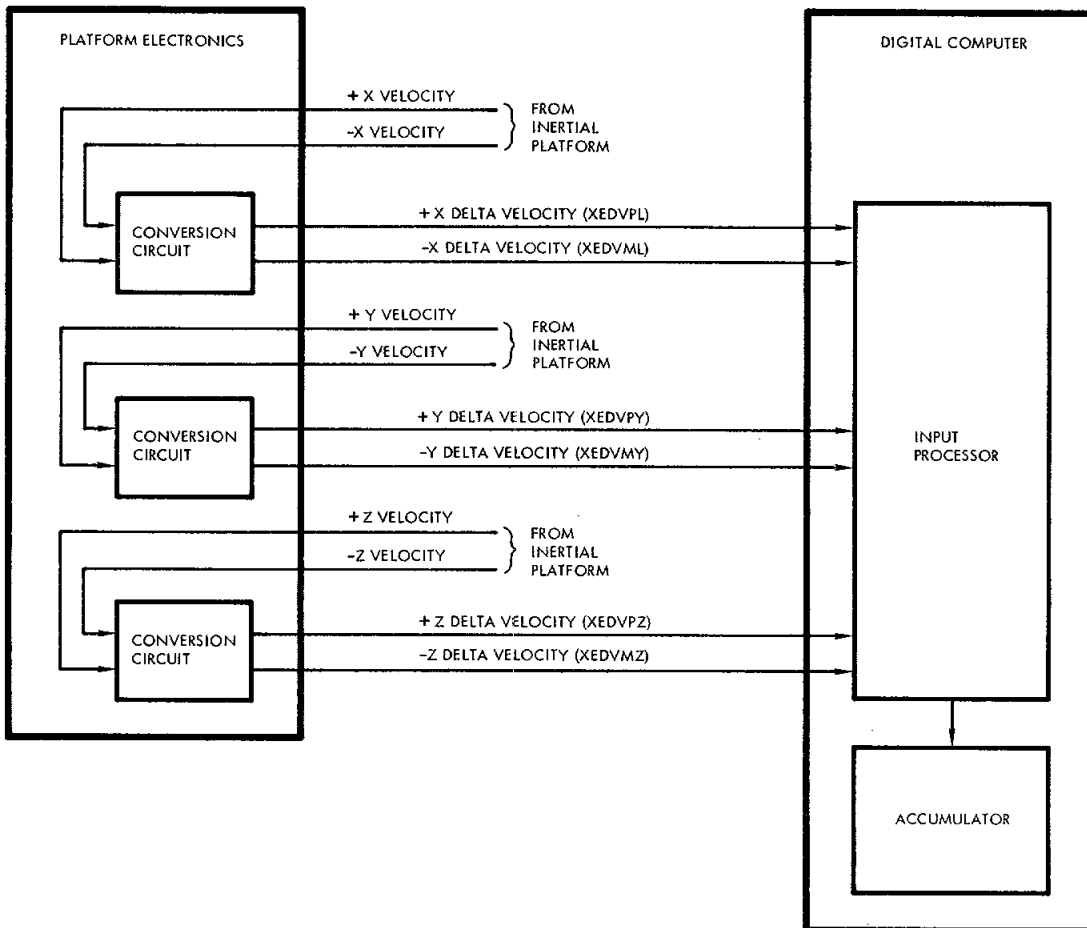
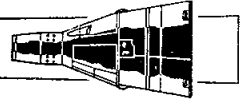

Figure 8-30 Computer-Platform Electronics Interface



# PROJECT GEMINI



<u>Signal</u>	<u>Address</u>		<u>Processor</u>
	<u>X</u>	<u>Y</u>	<u>PHASE TIME</u>
Read X delta velocity	5	4	2
Read Y delta velocity	5	4	3
Read Z delta velocity	5	4	4

The input processor accumulates the incremental velocity pulses on the processor delay line in two's-complement form. The velocity pulses have a maximum frequency of 3.6 kc per channel with a minimum separation of 135 usec between any plus and minus pulse for a given axis. Three input circuits are used to buffer the plus and minus pulses, one circuit for each axis. The buffered velocity pulse inputs are sampled during successive processor phases and read into a control circuit. This control circuit synchronizes the inputs with the processor timing and establishes an add, subtract, or zero control for the processor carry-borrow circuit. The accumulated velocity quantities are read into the accumulator S, and 1 through 12 bit positions in two's-complement form via a single PRO45 instruction, as follows:

- (a) Processor phase 2 - read accumulated X velocity
- (b) Processor phase 3 - read accumulated Y velocity
- (c) Processor phase 4 - read accumulated Z velocity

As the accelerometer values are read into the accumulator, the delay line is automatically zeroed so that each reading represents the change in velocity from the previous reading.

The computer inputs from the System Electronics are summarized as follows:



# PROJECT GEMINI



- (a) +X delta velocity (XEDVPL)
- (b) -X delta velocity (XEDVML)
- (c) +Y delta velocity (XEDVPY)
- (d) -Y delta velocity (XEDVMY)
- (e) +Z delta velocity (XEDVPZ)
- (f) -Z delta velocity (XEDVMZ)

## IGS Power Supply (Figure 8-31)

The computer supplies a filtered 28 vdc signal to the IGS Power Supply to control the dc power supplied to the computer. The IGS Power Supply supplies power to the computer within 0.3 second after receiving the 28 vdc power control signal. When the computer power control signal drops to 2 vdc, the IGS Power Supply removes dc power from the computer within 0.3 second. The 26 vac, 400 cps power furnished to the computer by the IGS Power Supply is not controlled by the computer power control signal, and is therefore present at the computer whenever the IGS Power Supply is operating.

The computer inputs from the IGS Power Supply are summarized as follows:

- (a) -27.2 vdc (XSP27VDC) and return (XSP27VDCRT)
- (b) -27.2 vdc (XSM27VDC) and return (XSM27VDCRT)
- (c) -20 vdc (XSP20VDC) and return (XSP20VDCRT)
- (d) +9.3 vdc (XSP9VDC) and return (XSP2VDCRT)
- (e) 26 vac (XS26VAC) and return (XS26VACRT)
- (f) +28 vdc filtered (XSP28VDC) and return (XSP28VDCRT)

The computer output to the IGS Power Supply is summarized as follows:

Power control (XCEP)



# PROJECT GEMINI

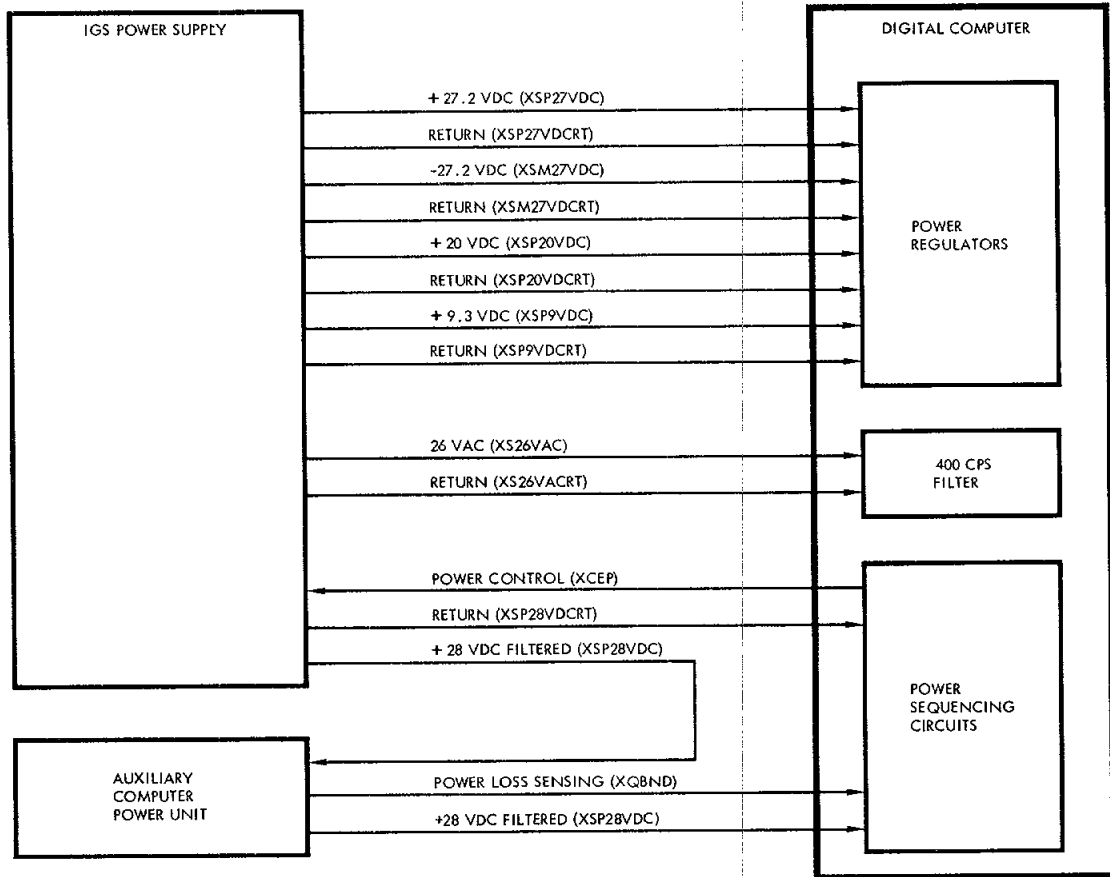
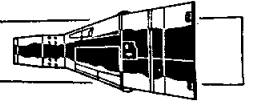
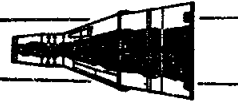

Figure 8-31 Computer-Power Supply Interface



# PROJECT GEMINI



## Auxiliary Computer Power Unit (ACPU) (Figure 8-31)

The ACPU functions in conjunction with the IGS Power Supply to buffer power interruptions and depressions. When the ACPU senses a power interruption or depression, it supplies the power loss sensing signal to the power sequencing circuits in the computer. The ACPU then maintains the computer power constant until the power interruption or depression ends (up to a maximum of 100 msec).

The computer output to the ACPU is summarized as follows:

Power Control (XCEP)

The computer input from the ACPU is summarized as follows:

Power loss sensing (XQBND)

+28 vdc filtered (XSP28VDC)

## Manual Data Insertion Unit (MDIU) (Figure 8-32)

The MDIU can insert into, and/or read out of, the computer up to 99 data words. It provides the crew with a means of updating certain data stored in the computer by inserting new data into the appropriate memory location. It also provides a capability to verify the data stored in a number of additional memory locations. Two of the quantities which may be inserted ( $T_R$  and  $T_X$ ) are transferred to the Time Reference System by the computer, following insertion.

The MDIU consists of two units: The Manual Data Keyboard (MDK) and the Manual Data Readout (MDR). The MDK has a keyboard containing 10 push-button switches used during data insertion and readout. To insert data, the pilot always depresses seven data-insert push-button switches; the first two set up the address of the computer memory location in which data is to be stored, and the last five

PROJECT GEMINI

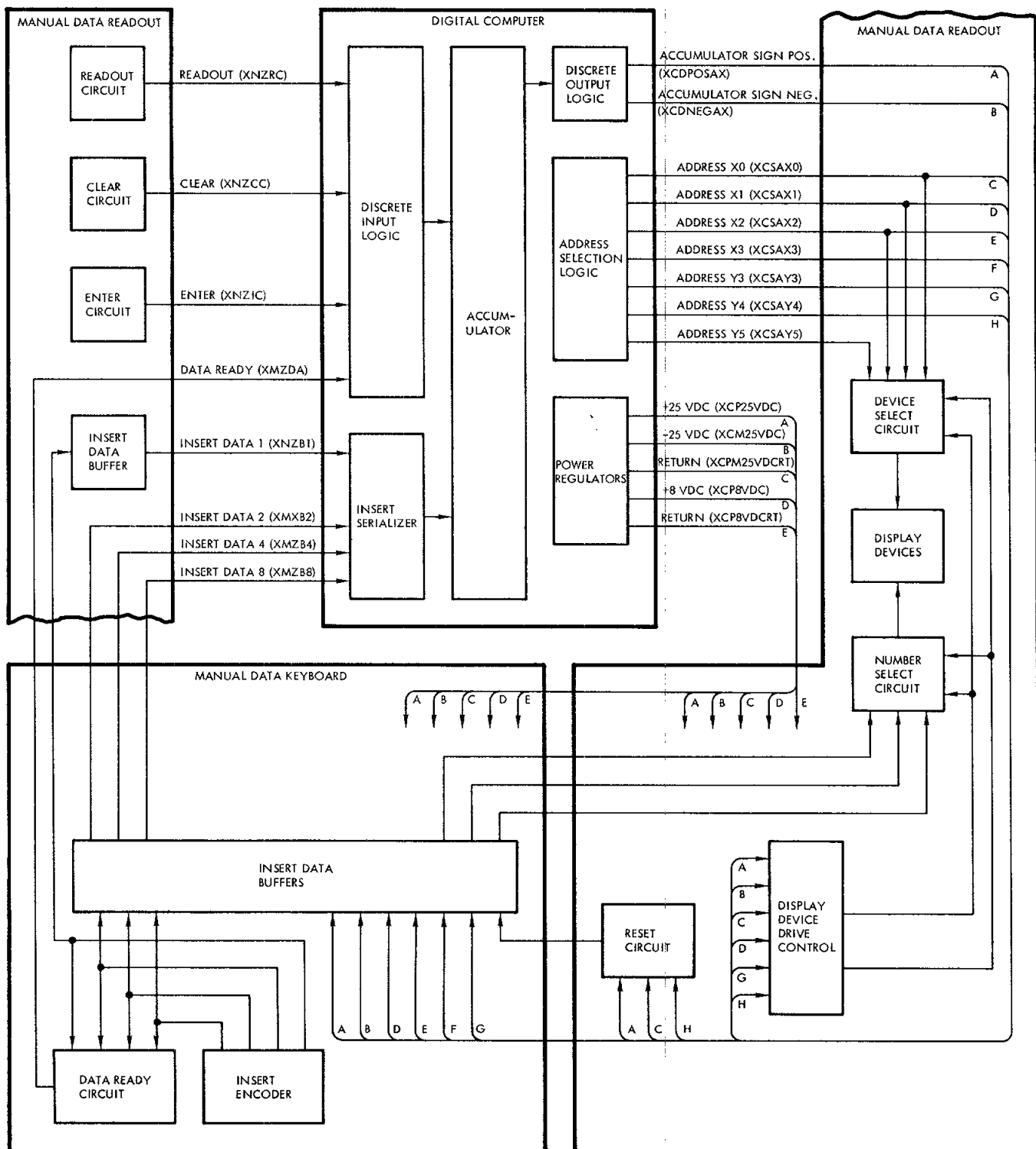

Figure 8-32 Computer-MDIU Interface



# PROJECT GEMINI



set up the actual data. Each digit inserted is also displayed for verification. Following the insertion and verification of the seventh digit, the ENTER push-button switch is pressed to store the data in the selected memory location. If verification of any digit cannot be made, the CLEAR push-button switch is pressed and the address and data must be set up again. The MDR sequentially displays for verification the digits inserted by the pilot. This unit can also be used to re-check quantities stored in the computer memory. This operation is accomplished by inserting and verifying only the first two (address) digits and then depressing the READ OUT push-button switch. The selected data is then displayed for verification. If the pilot attempts to insert data in an invalid address, attempts to read data out of an invalid address, inserts more than seven digits, or fails to insert a two-digit address prior to depressing the ENTER or READ OUT push-button switch, the seven digits displayed are all zero indicating a pilot error.

The following CLD instruction programming is associated with the MDIU interface:

<u>Signal</u>	<u>Address</u>	
	<u>X</u>	<u>Y</u>
Data ready	1	0
Enter	2	0
Readout	3	0
Clear	4	0

The following PRO instruction programming is associated with the MDIU interface:

<u>Signal</u>	<u>Address</u>	
	<u>X</u>	<u>Y</u>
Digit magnitude weight 1	0	3



**PROJECT GEMINI**

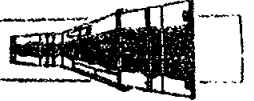

<u>Signal (cont.)</u>	<u>Address (cont.)</u>	
	<u>X</u>	<u>Y</u>
Digit magnitude weight 2	1	3
Digit magnitude weight 4	2	3
Digit magnitude weight 8	3	3
Reset DI01, DI02, and DI03	0	4
Display device drive	1	4
Digit select weight 1	0	5
Digit select weight 2	1	5
Digit select weight 4	2	5
Read MDIU insert data	3	4

The pilot must depress the CLEAR push-button switch for the first quantity to be inserted or displayed. Upon the recognition of DI04 on, the program sets DO40 off. This results in resetting DI01, DI02, and DI03, and clearing the MDIU buffer. The program then sets DO41 off to reset the display drivers.

When a digit push-button switch is depressed, the binary coded decimal (BCD) code is entered into the buffer and DI01 is turned on. The program reads the buffer into accumulator bit positions 1 through 4 and sets DO40 off. Following this, the program sends out a code by means of DO50, DO51, and DO52 to select the digit to be displayed. The program then sets DO41 on to turn on the display drivers, and sends a BCD digit to the buffer by means of DO30, DO31, DO32, and DO33. The program waits 0.5 second and sets DO40 and DO41 off. The pilot must wait until the digit is displayed before entering the next digit. After all seven digits have been entered and displayed, the pilot depresses the ENTER push-button switch. This results in DI02 being set on. The program then sets DO40 off, and converts



# PROJECT GEMINI



the five data digits to binary. This data is scaled and stored in memory according to the two-digit address.

To read data out of the computer, the pilot enters the two-digit address of the quantity to be displayed and then depresses the READ OUT push-button switch. This results in DIO3 being set on. The computer then sets DO40 off, converts the requested quantity to BCD, and sends the BCD data to the display buffer one digit at a time in 0.5-second intervals.

The computer inputs from the MDIU are summarized as follows:

- (a) Readout (MZRC) - The up level of this signal denotes that the two previously inserted digits are to be used as the address of a quantity to be displayed.
- (b) Clear (XNZCC) - The up level of this signal denotes that the previously inserted digits are incorrect and the insert sequence must be repeated.
- (c) Enter (XNZIC) - The up level of this signal denotes that the previously inserted digits have been verified and should be stored in the computer memory.
- (d) Data ready (XMZDA) - The up level of this signal denotes that a digit has been inserted. The computer samples this line at least 20 times per second to allow continuous insertion of data.
- (e) Insert data 1, 2, 4, and 8 (XNZB1, XMZB2, XMZB4, and XMZB8) - These four signals, denoting one BCD character, are supplied to the com-



# PROJECT GEMINI



puter for each decimal digit inserted.

The computer outputs to the MDIU are summarized as follows:

- (a) Accumulator sign positive (XCDPOSAX) - The up level of this signal on a set input causes the addressed latch to be set.
- (b) Accumulator sign negative (XCDNEGAX) - The up level of this signal on a reset input causes the addressed latch to be reset.
- (c) Addressing - Seven lines provide the capability of addressing all latches in the MDIU. The following X and Y address lines are provided:

- (1) MDIU address X0 (XCSAX0)
- (2) MDIU address X1 (XCSAX1)
- (3) MDIU address X2 (XCSAX2)
- (4) MDIU address X3 (XCSAX3)
- (5) MDIU address Y3 (XCSAY3)
- (6) MDIU address Y4 (XCSAY4)
- (7) MDIU address Y5 (XCSAY5)

By selecting one X and one Y address line at a time, a total of 12 addresses can be formed.

- (d) Power - Regulated dc power is supplied to the MDIU as follows:
  - (1) +25 vdc (XCP 25VDC) and return (XCPM25VDCRT)
  - (2) -25 vdc (XCM25 VDC) and return (XCPM25VDCRT)
  - (3) +8 vdc (XCP8VDC) and return (XCP8VDCRT)



# PROJECT GEMINI

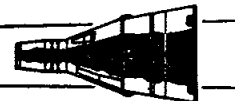

## Time Reference System (TRS) (Figure 8-33)

The TRS counts Elapsed Time (ET) from lift-off through impact, counts down time to retrograde ( $T_R$ ) on command, and counts down time to equipment reset ( $T_X$ ) on command, all in 1/8-second increments. The computer receives  $T_R$  and  $T_X$  data words from the MDIU and automatically transfers them to the TRS. When the computer receives a display request from the MDIU for  $T_R$ , or when the computer program requires ET, the TRS transfers them to the computer.

The following CLD instruction programming is associated with the TRS interface.

<u>Signal</u>	<u>Address</u>	
	<u>X</u>	<u>Y</u>
$T_R$ discrete	5	0

The following PRO instruction programming is associated with the TRS interface:

<u>Signal</u>	<u>Address</u>	
	<u>X</u>	<u>Y</u>
ET control	4	1
$T_X$ control	5	2
$T_R$ control	5	6
Enter	1	2
TRS data and timing pulses	0	2
TRS control reset	4	1

In the readout mode, the computer transfers  $T_R$  or  $T_X$  data words to the TRS. The mode is initiated by setting D021 on. The 24 bits of data to be sent to the TRS

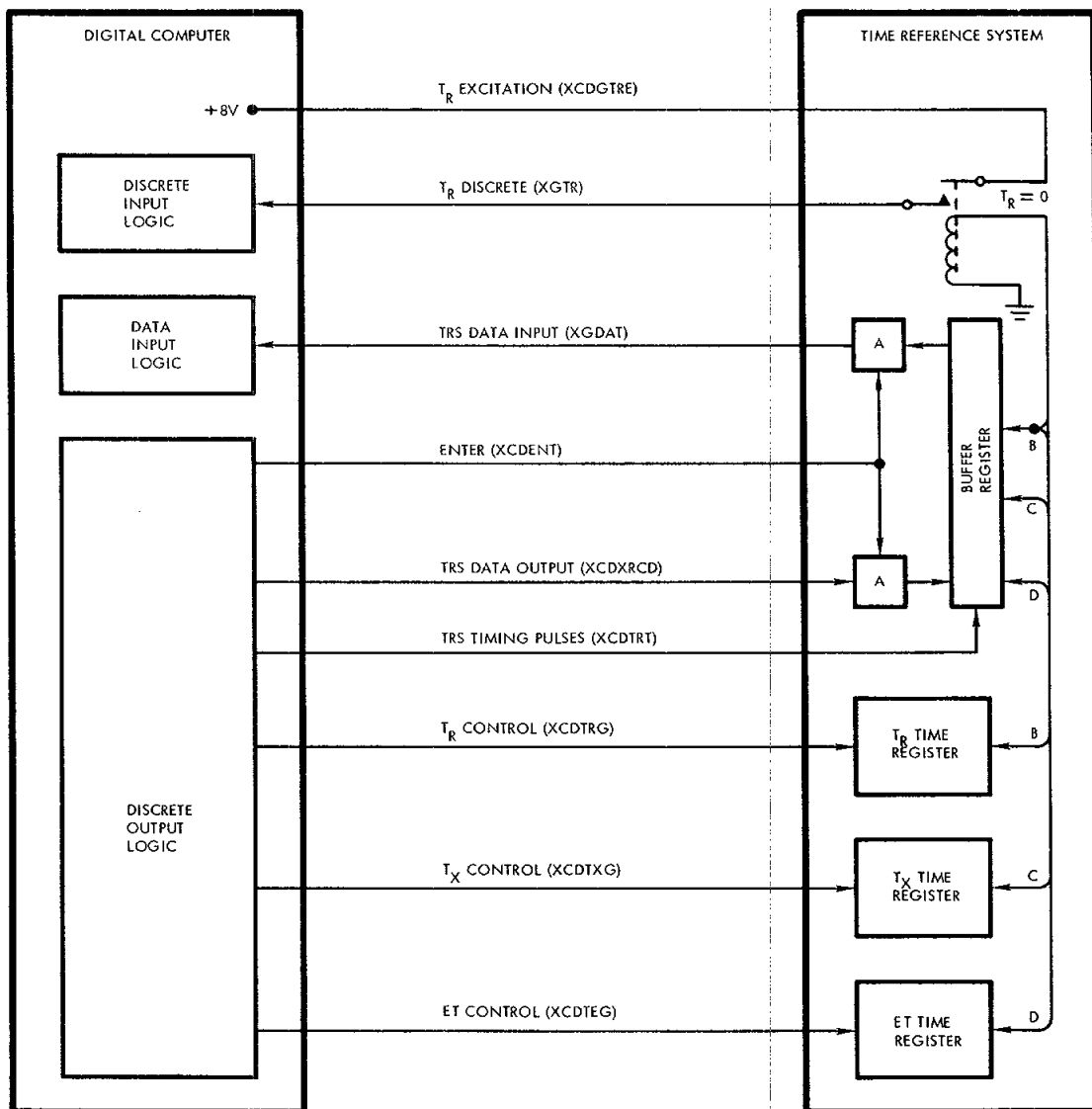
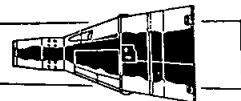

Figure 8-33 Computer-TRS Interface



# PROJECT GEMINI



are then placed in the accumulator by 2<sup>4</sup> consecutive sets of PRO20 and SHR1 (shift right one place) instructions. With each PRO instruction, a timing pulse is automatically initiated 70 usec after the beginning of the data pulse. The timing pulse is terminated so that its up level is 139 usec. After bit 2<sup>4</sup> has been sent to the TRS, the program generates one of two control gates ( $T_R$  or  $T_X$ ). Between 9 and 15 ms later, the computer terminates the TRS control gate.

The enter mode is initiated by setting DO21 off. One of two control gates ( $T_R$  or  $T_X$ ) is generated by the program and terminated between 9 and 15 ms later. After termination of the control gate, the program enters a subroutine consisting of 25 consecutive sets of PRO10 and SHR1 instructions. Every time a PRO operation is called for, a timing pulse is generated by the same logic as in the readout mode. The timing pulse is sent to the TRS to cause the addressed data to be supplied to the computer. The first bit received is discarded with the final SHR1 instruction. The second bit received is the least significant bit and is shifted into accumulator bit position 25 at the completion of the twenty-fifth set of PRO20 and SHR1 instructions. When  $T_R$  equals zero, a relay in the TRS connects the  $T_R$  excitation line to the  $T_R$  discrete line. The  $T_R$  discrete signal then causes the computer to start re-entry calculations.

The computer inputs from the TRS are summarized as follows:

- (a)  $T_R$  discrete (XGTR) - The up level of this signal signifies that the computer should begin re-entry calculations.
- (b) TRS data input (XGDAT) - All data transfers from the TRS to the computer occur on this line. The data word on the line is determined by which control gate the computer actuates prior to the



# PROJECT GEMINI



actual data transfer. The up level is a binary 1.

The computer outputs to the TRS are summarized as follows:

- (a)  $T_R$  excitation (SCDGTRE) - The computer supplies +8 vdc through a resistor to the TRS as the  $T_R$  excitation input. When  $T_R$  equals zero, the  $T_R$  relay causes the  $T_R$  excitation input to be transferred to the computer as the  $T_R$  discrete signal.
- (b) Enter (XCDENT) - The up level of this signal signifies that data is to be transferred from the TRS to the computer when the transfer clocks occur. The down level signifies that data is to be transferred from the computer to the TRS.
- (c) TRS data output (XCDXRCD) - All data transfers from the computer to the TRS occur on this line. The data word on the line is determined by which control gate ( $T_R$  or  $T_X$ ) the computer has actuated. The up level is a binary 1.
- (d) TRS timing pulses (XCDTRT) - These 3.57 kc timing pulses cause the computer data to be shifted into or out of the TRS buffer register for transfer to or from the computer.
- (e)  $T_R$  control (XCDTRG) - The up level of this signal causes the transfer of data between the TRS buffer register and the TRS  $T_R$  register. The direction of transfer is determined by the level of the enter signal.
- (f)  $T_X$  control (XCDTXG) - The up level of this signal causes the trans-



# PROJECT GEMINI



fer of data between the TRS buffer register and the TRS  $T_x$  register. The direction of transfer is determined by the level of the enter signal.

- (g) ET control (XCDTEG) - The up level of this signal causes the transfer of data between the TRS buffer register and the TRS ET register. The direction of transfer is determined by the level of the enter signal.

## Digital Command System (DCS) (Figure 8-34)

The DCS accepts BCD messages from the ground stations at a 1 kc rate, decodes the messages, and routes the data to either the TRS or the computer. In addition, the DCS can generate up to 64 discrete commands.

<u>Signal</u>	<u>Address</u>	
	<u>X</u>	<u>Y</u>
DCS ready	6	0

The following PRO instruction programming is associated with the DCS interface:

<u>Signal</u>	<u>Address</u>	
	<u>X</u>	<u>Y</u>
Computer ready	1	0
DCS shift pulse gate	0	0

When data is to be sent to the computer, the DCS supplies the computer with a DCS ready discrete input (DIO6). This input is sampled every 50 ms or less in all computer modes except during the 1/8-second interval in the ascent mode when reading ET at lift-off. To receive DCS data, the computer supplies a series of 24 DCS

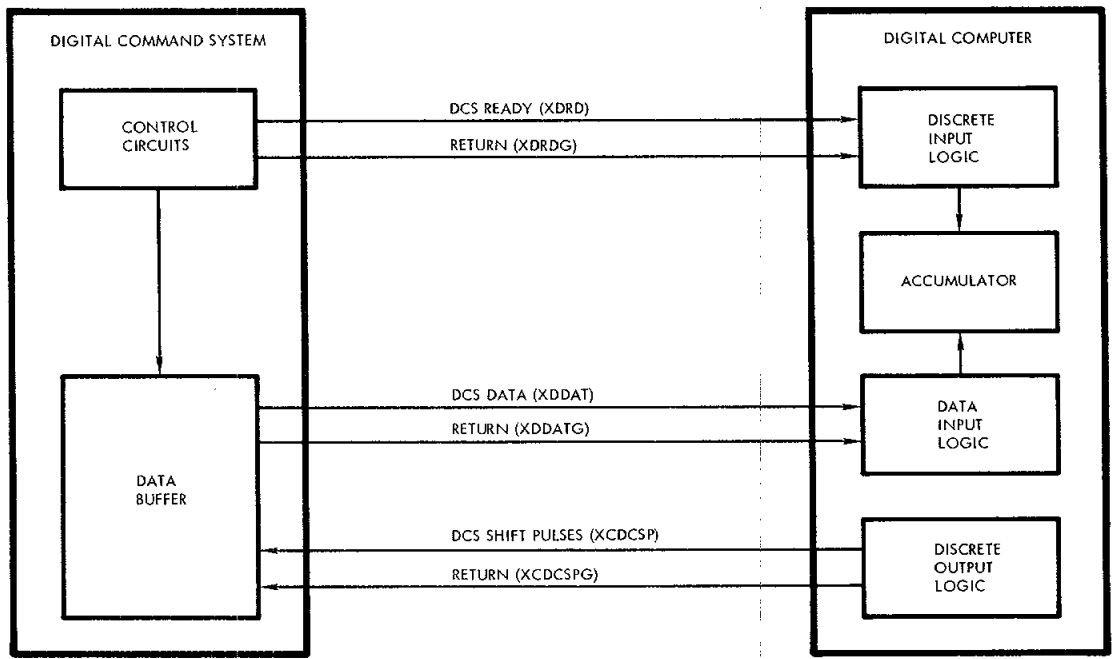

Figure 8-34 Computer-DCS Interface



# PROJECT GEMINI



shift pulses at a 500 kc repetition rate by setting D001 off and programming a PROO instruction. These shift pulses cause the data contained in the DCS buffer register to be shifted out on the DCS data line and read into accumulator bit positions 1 through 24, with position 19 through 24 containing the assigned address of the associated quantity and position 1 through 18 containing the quantity. Bit position 19 (address portion) and bit position 1 (data portion) are the most significant bits.

The computer inputs from the DCS are summarized as follows:

- (a) DCS ready (XDRD) and return (XDRDG) - The down level of this signal signifies that the DCS is ready to transfer data to the computer.
- (b) DCS data (XDDAT) and return (XDDATG) - This serial data from the DCS consists of 24 bits, with 6 being address bits and 18 being data bits.

The computer output to the DCS is summarized as follows:

DCS shift pulses (XCDCSP) and return (XCDCSPG) - The computer supplies these 24 shift pulses to the DCS to transfer data contained in the DCS buffer register out on the DCS data line.

## Rendezvous Radar (Figure 8-35)

The Rendezvous Radar supplies the computer with three data inputs: line-of-sight range to target, sine of azimuth, and sine of elevation. In the rendezvous mode, the computer uses radar data to compute and display velocity to be gained (in body coordinates).

# PROJECT GEMINI

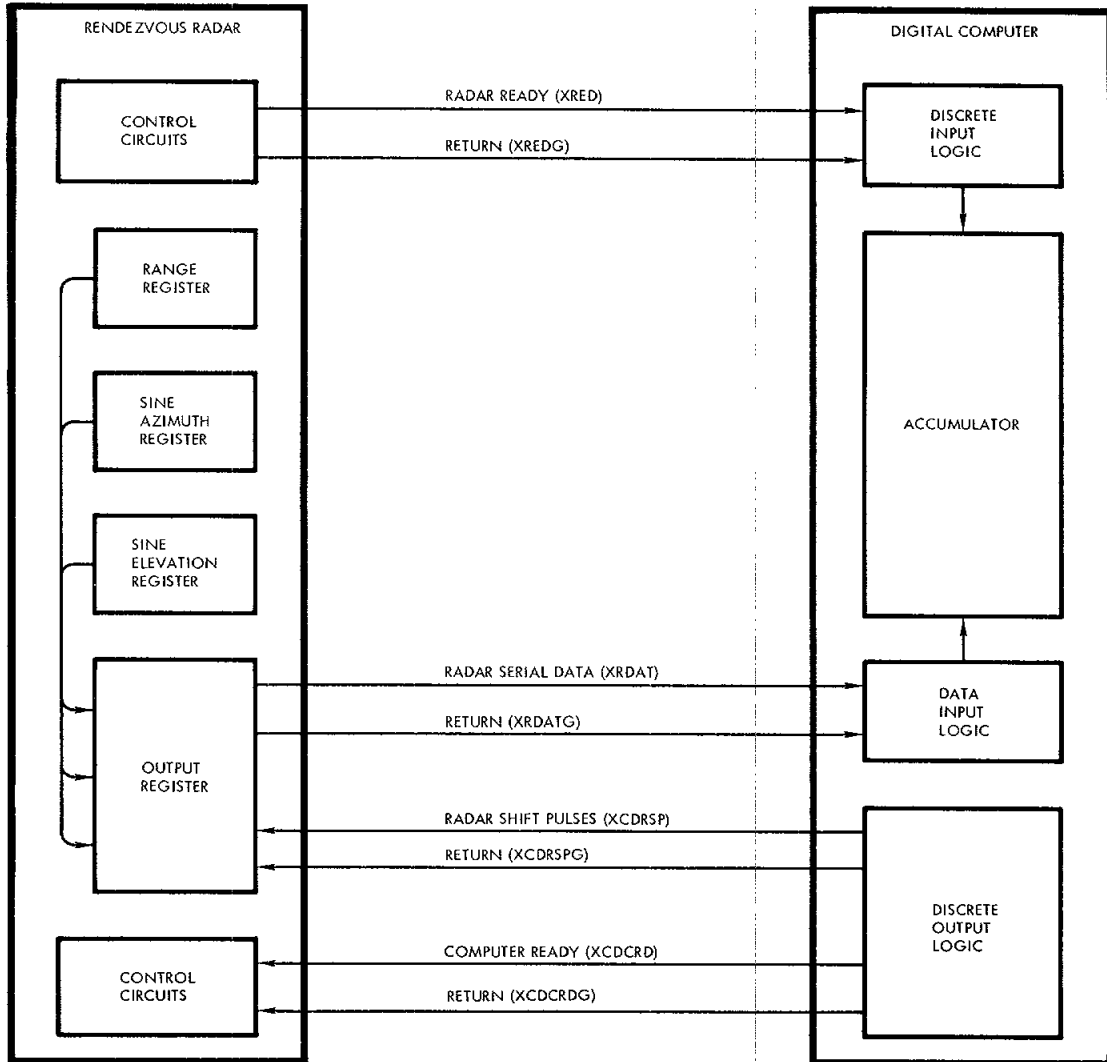

Figure 8-35 Computer-Radar Interface



**PROJECT GEMINI**



The following CLD instruction programming is associated with the Rendezvous Radar interface:

<u>Signal</u>	<u>Address</u>	
	<u>X</u>	<u>Y</u>
Radar ready	<u>0</u>	<u>0</u>

The following PRO instruction programming is associated with the Rendezvous Radar interface:

<u>Signal</u>	<u>Address</u>	
	<u>X</u>	<u>Y</u>
Computer ready	1	0
Reset radar ready	3	6
DCS shift pulse gate	0	0

When the computer requires radar data, the computer ready discrete output (DOO1) is supplied to the Rendezvous Radar. Prior to this, the program has reset the radar ready discrete input buffer with the PRO63 instruction. The computer ready signal causes the radar to stop updating its internal data and to enter a hold mode following completion of a data acquisition cycle. The program waits 20 ms and tests the radar ready discrete input (DIO0). If the test is negative, three consecutive sets of PRO00 and STO instructions are given. Each PRO instruction causes a burst of fifth-two 500 kc pulses to be sent to the radar to shift out the contents of the radar data output register. The data appears in the output register in the following sequence:



# PROJECT GEMINI



- (a) Range - 15 bits
- (b) Sine azimuth - 10 bits
- (c) Sine elevation - 10 bits

A delay of 280 usec occurs before the leading pulse of each 500 kc burst to enable the computer to store the data it has received and to allow the next data word to be inserted into the radar data output register in preparation for transmission to the computer.

Radar range data is read in true magnitude form into accumulator bit positions 8 through 24. If bit positions 8 through 11 (four most significant bits) are 1's, the radar range data is considered unreliable and is ignored. Sine azimuth and sine elevation data are read into accumulator bit positions 15 through 24.

The computer inputs from the Rendezvous Radar are summarized as follows:

- (a) Radar ready (XRED) and return (XREDG) - The up level of this signal signifies that the radar has recognized the computer ready signal and is ready to transfer data. The radar ready pulse occurs between 0 and 4000 usec after the computer ready pulse, if radar lock-on has occurred.
- (b) Radar serial data (XRDAT) and return (XRDATG) - This data consists of three words which occur in a fixed format as determined by the radar shift pulses. The first word is range to target (15 bits), the second word is sine of azimuth angle (10 bits), and the third word is sine of elevation angle (10 bits).



# PROJECT GEMINI



The computer outputs to the Rendezvous Radar are summarized as follows:

- (a) Radar shift pulses (XCDRSP) and return (XCDRSPG) - These 500 kc pulses are issued between 280 usec and 5 millisecc after the computer receives the radar ready signal. They are sent out as three groups of 52 pulses each, with a 280 usec delay before the leading edge of each group.
- (b) Computer ready (XCDCRD) and return (XCDCRDG) - The up level of this signal signifies that the computer requires radar data inputs.

## Attitude Display/Attitude Control and Maneuver Electronics (ACME) (Figure 8-36)

During the ascent mode, the computer generates pitch, roll, and yaw attitude error signals and supplies them to the Attitude Display. The pilot utilizes the Attitude Display to monitor the performance of the ascent guidance equipment.

During the catch-up and rendezvous modes, the computer generates pitch and yaw attitude error signals and is capable of supplying them to the Attitude Display and the ACME.

During the re-entry mode, the computer generates a roll attitude error or bank rate signal and supplies it to the Attitude Display and the ACME. If range to touchdown with zero lift is equal to the computed range to the desired touchdown point, a bank rate command equivalent to a 15 degree per second roll rate is provided on the roll attitude error output line. If the range to touchdown with zero lift is not equal to that for the desired touchdown point, the appropriate roll rate or roll attitude signal is supplied on the output line. Also, during the re-entry mode, the computer generates cross range and down range error signals and supplies



# PROJECT GEMINI



them to the Attitude Display for the pilots' use in manually controlling the re-entry flight path of the spacecraft.

The following PRO instruction programming is associated with the Attitude Display and ACME interfaces:

<u>Signal</u>	<u>Address</u>	
	<u>X</u>	<u>Y</u>
Pitch error command	7	0
Yaw error command	7	1
Roll error command	7	2
Pitch resolution	2	0
Yaw resolution	3	0
Roll resolution	4	0

The pitch, yaw, and roll error commands are written into a seven-bit register from accumulator bit positions 5, and 8 through 13, with a PRO instruction having an X address of 7. The outputs of the register are connected to ladder decoding networks which generate a dc voltage equivalent to the buffered digital error. This analog voltage is then sampled by one of three sample and hold circuits; while one circuit is sampling the ladder output, the other two circuits are holding their previously sampled value. The minimum sample time is 2 ms, and the maximum hold time is 48 ms. The Y address of the previously mentioned PRO instruction selects the one sample and hold circuit that is to sample the ladder output. The output of each sample and hold circuit is fed into an individual ladder amplifier where



# PROJECT GEMINI



the DC analog voltage for each channel is made available for interfacing with the Titan Autopilot.

The dc analog outputs are also fed through individual range switches and magnetic modulators where the dc voltages are converted to 400-cycle analog voltages. The range switches, which are controlled by means of discrete outputs, can attenuate the dc voltages being fed into the magnetic modulators by a factor of 6-to-1. The addressing of the discrete outputs for controlling the range switches is as follows:

- (a) Pitch or down range error (D002) -
  - (b) Yaw or cross range error (D003) -
  - (c) Roll error (D004) -
- } plus for low range;  
} minus for high range.

The error commands are written every 50 ms or less. The updating period, however, is dependent upon the computer mode of operation. For the catch-up, rendezvous, and re-entry modes (and the orbital insertion phase of ascent guidance), the error commands are updated once per computation cycle or every 0.5 second or less. For first and second stage ascent guidance, the error commands are updated every 50 ms or less.

The computer outputs to the Attitude Display and ACME are summarized as follows:

- (a) Pitch attitude error (SCLPDRM) and return (XCLPDRMG) -  
Two identical sets of outputs (A and B) are time-shared between pitch attitude error (during ascent, catch-up and rendezvous)



# PROJECT GEMINI



and down range error (during Re-entry).

- (1) Pitch attitude error (ascent) to Attitude Display
  - (2) Pitch attitude error (catch-up and rendezvous) to Attitude Display
  - (3) Down range error (re-entry) to Attitude Display
- (b) Roll attitude error/bank rate command (XCLROIM) and return (XCLROIMG) - Two identical sets of outputs (A and B) are time-shared between roll attitude error and bank rate command. During ascent, it represents only roll attitude error. During re-entry, however, it represents roll attitude error when the computed range is less than the desired range, and a 20 degree per second bank rate command when the computed range equals or exceeds the desired range.
- (1) Roll attitude error (ascent) to Attitude Display
  - (2) Roll attitude error (re-entry) to Attitude Display  
and ACME
  - (3) Bank rate command (re-entry) to Attitude Display  
and ACME
- (c) Yaw attitude error (XCLYCRM) and return (XCLYCRMG) - Two identical sets of outputs (A and B) are time-shared between yaw attitude error (during ascent, catch-up, and rendezvous) and cross range error (during re-entry).



# PROJECT GEMINI



- (1) Yaw attitude error (ascent) to Attitude Display
- (2) Yaw attitude error (catch-up and rendezvous) to Attitude Display
- (3) Cross range error (re-entry) to Attitude Display

## Titan Autopilot (Figure 8-37)

During ascent, the computer performs guidance computations in parallel with the Titan guidance and control system. If a malfunction occurs in the Titan system, the pilot can switch control to the Inertial Guidance System. For a description of the program requirements and operation associated with the Titan Autopilot interface, refer to the Attitude Display and ACME interface description.

The computer outputs to the Titan Autopilot are summarized as follows:

- |   |   |   |
|---|---|---|
| (a) Pitch error (XCLPDC) -  | } | These signals are provided during backup ascent guidance. |
| (b) Roll error (XCLRDC) -   |   |   |
| (c) Yaw error (XCLYDC) -  |   |   |
| (d) Common return (XCLDCG) -  |   |   |
| (e) Autopilot scale factor (XCDAPSF) - This signal changes the autopilot dynamics after the point of maximum dynamic pressure is reached. |   |   |
| (f) Second stage engine cutoff (XCDSSCF) - This signal is generated when velocity to be gained equals zero.                               |   |   |



# PROJECT GEMINI

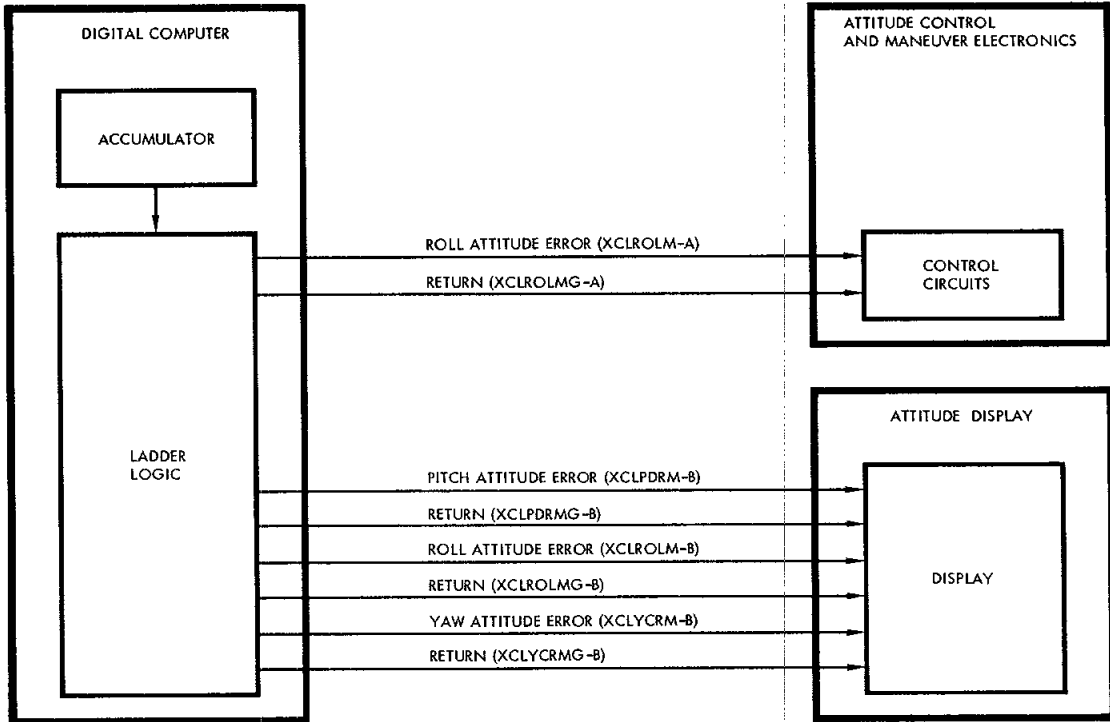
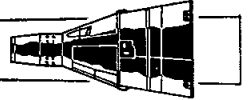

Figure 8-36 Computer-Attitude Display/ACME Interface

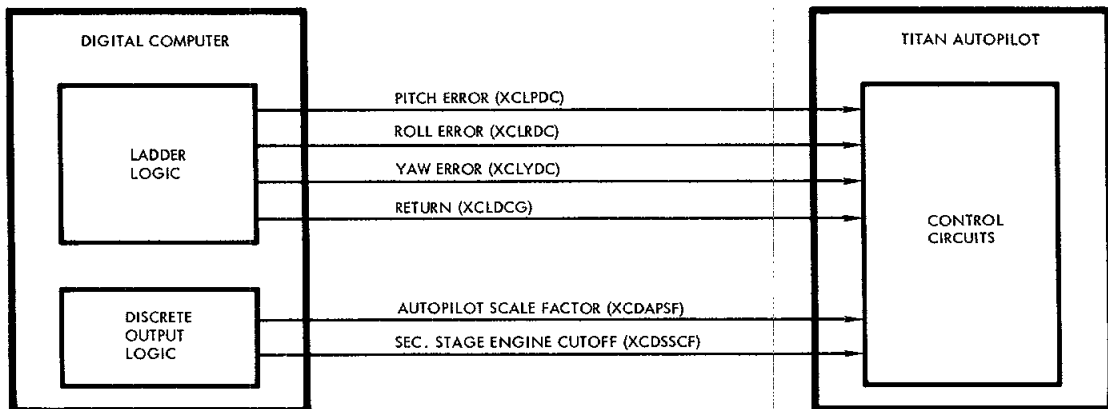

Figure 8-37 Computer-Autopilot Interface



# PROJECT GEMINI



## Auxiliary Tape Memory (ATM) (Figure 8-38)

The ATM is interfaced with the Digital Computer and the following controls and indicators on the Pilots' Control and Display Panel (PCDP):

- ATM mode switch
- ATM ON/RESET switch
- ATM ERROR indicator
- ATM RUN indicator

The crew, via the PCDP and the computer, controls the modes of ATM operation. The Incremental Velocity Indicator (IVI) and the ATM ERROR and RUN indicators are used to provide information on ATM status. The crew also uses the Manual Data Insertion Unit (MDIU) for communication with the computer and subsequent computer communication with the ATM.

The following CLD instruction programming is associated with the ATM interface:

<u>Signal</u>	<u>Address</u>	
	<u>X</u>	<u>Y</u>
ATM clock	1	4
ATM on	3	3
ATM data channel 2	3	4
ATM mode control number 1	4	1
ATM beginning or end of tape	4	3
ATM data channel 3	4	4
ATM mode control number 2	5	1
ATM data channel 1	5	3

PROJECT GEMINI

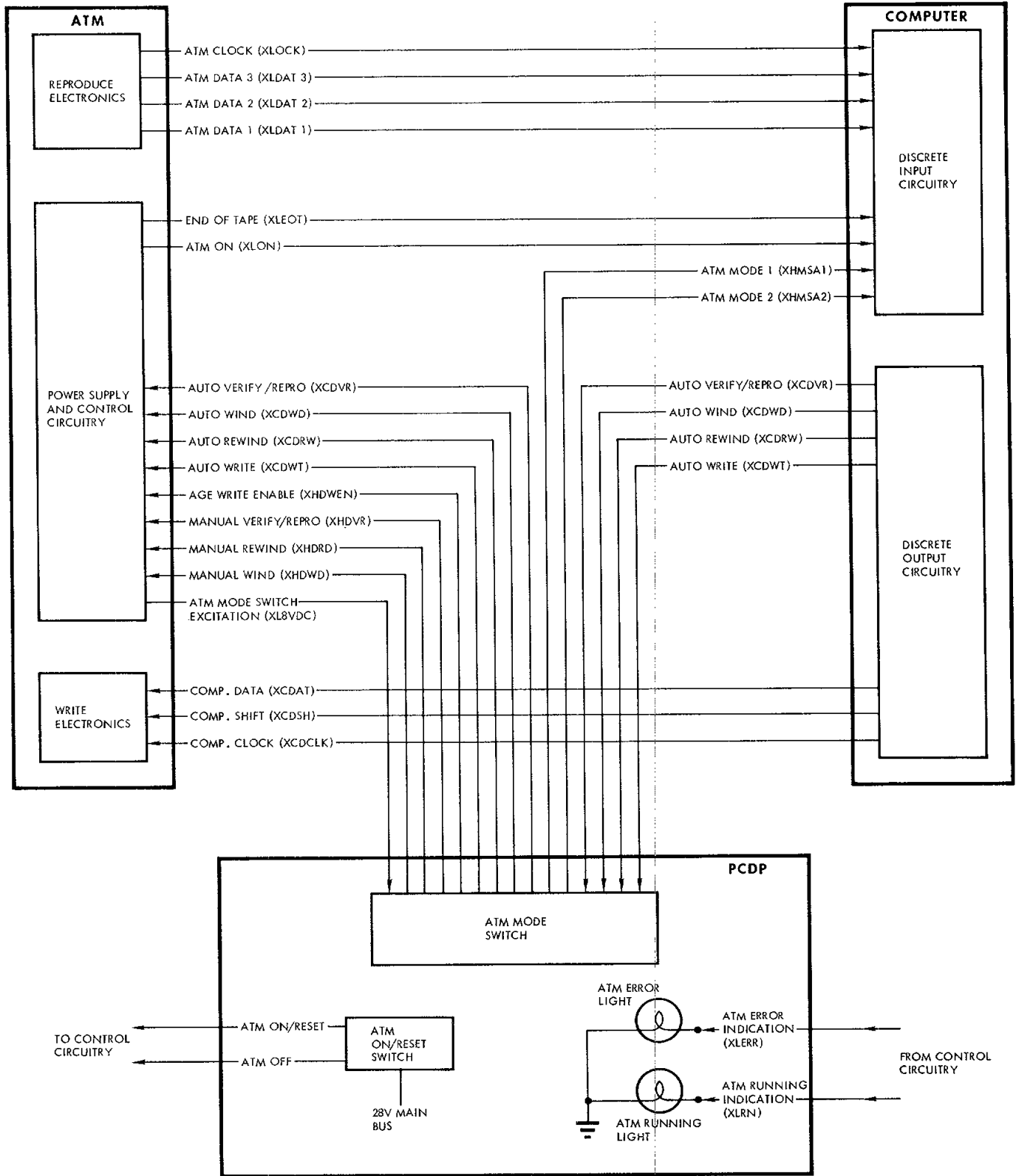
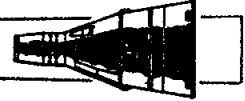

Figure 8-38 Computer-ATM-PCDP Interface (S/C 8 thru 12 Only)



# PROJECT GEMINI



The following PRO instruction programming is associated with the ATM interface:

<u>Signal</u>	<u>Address</u>	
	<u>X</u>	<u>Y</u>
ATM wind/rewind reset	4	1
ATM verify/reprogram command	4	4
ATM wind command	5	1
ATM rewind command	5	2

The computer inputs from the ATM are summarized as follows:

- (a) ATM clock (XLOCK) - A two millisecond pulse for each three-bit parallel data output frame, delayed 1520 microseconds from the nominal beginning of each frame. Up level six to twelve volts; down level less than one volt. Rise and fall times less than 20 microseconds each.
- (b) ATM data 1 (XLDAT 1), data 2 (XLDAT 2), data 3 (XLDAT 3) - Parallel NRZ data output on three lines at a rate of 200 bits per second on each line. Individual bit periods are written  $\pm 2\%$  of normal. Other specifications same as for data outputs.
- (c) End-of-tape (XLEOT) - A logic level from the ATM to the computer. An up level indicates that either end of the tape has been reached.
- (d) ATM on (XLON) - A logic signal from the ATM to the computer. An up level indicates that the ATM has reached proper operating speed in the read and write modes. This signal appears approximately



# PROJECT GEMINI



five seconds after a command is given to the ATM to read or write. It is inhibited when either end of the tape is reached.

The computer outputs to the ATM are summarized as follows:

- (a) Auto verify/reprogram (XCDVR) - A command line from the computer, through the AUTO position of the AUX TAPE mode switch, to the ATM. An 8 vdc signal on this line causes the ATM to operate in the record or write mode in the forward direction at a nominal tape speed of 1.5 ips.
- (b) Auto wind (XCDWD) - An 8 vdc signal from the computer through the AUTO position of the AUX TAPE mode switch, to the ATM. This signal causes the tape to move in the forward direction at a nominal tape speed of 12 ips. The ATM functions internally in the read mode during this operation.
- (c) Auto rewind (XCDFW) - An 8 vdc signal from the computer, through the AUTO position of the AUX TAPE mode switch, to the ATM. This signal causes the tape to move in the reverse direction at a nominal tape speed of 12 ips.
- (d) Auto write (XCDWT) - A signal from the computer, through the AUTO position of the AUX TAPE mode switch, to the ATM. The signal is used by the ATM to set up internal controls such that computer data can be recorded on the tape.
- (e) Computer data (XCDAT) - Groups of four serial NRZ data bits, each group or frame totaling 1120 microseconds duration at a rate of



# PROJECT GEMINI



200 frames per second. Up level greater than seven volts; down level less than one volt. Rise time less than 15 microseconds; fall time less than ten microseconds.

- (f) Computer shift (XCDSH) - Groups of four serial pulses, each pulse having a period of 139 microseconds and spaced 141 microseconds from the next pulse. Shift input pulses begin 70 microseconds after the start of the data pulses. Up level greater than seven volts; down level less than one volt. Rise time less than 15 microseconds; fall time less than 0.4 microseconds.
  
- (g) Computer clock (XCDCLK) - Serial pulses having a duration of 18 microseconds each at a rate of 200 pulses per second or one per frame. These pulses are delayed 280 or 560 microseconds after the beginning of bit number four in each frame. Up level is seven to 14 volts; down level less than one volt. Rise time less than ten microseconds; fall time less than 0.5 microseconds.

Additional ATM - PCDP and PCDP - Computer interfaces are summarized as follows:

- (a) ATM mode switch excitation (XL8VDC) - A nominal 8 vdc excitation voltage from the ATM to the AUX TAPE mode switch on the PCDP.
  
- (b) AGE write enable (XHDWEN) - An 8 vdc discrete from the ATM, through the STANDBY position of the AUX TAPE mode switch, to the AGE to enable it to send a write command to the ATM.
  
- (c) Manual verify/reprogram (XHDVR) - An 8 vdc discrete from the AUX TAPE mode switch to the ATM which causes the ATM to operate in the write mode at a nominal tape speed of 1.5 ips.



# PROJECT GEMINI



- (d) Manual wind (XHDWD) - An 8 vdc discrete from the AUX TAPE mode switch to the ATM which causes the tape to move in a forward direction at a nominal tape speed of 12 ips.
- (e) Manual rewind (XHWRD) - An 8 vdc discrete from the AUX TAPE mode switch to the ATM which causes the tape to move in the reverse direction at a nominal tape speed of 12 ips.
- (f) ATM on/reset - A momentary 28 vdc signal from the AUX TAPE OFF-ON/RESET switch to the ATM. This signal will either initiate ATM operation (apply power) or re-initiate operation while extinguishing the AUX TAPE ERROR indicator on the PCDP.
- (g) ATM OFF - A momentary 28 vdc signal from the AUX TAPE OFF-ON/RESET switch to the ATM. It causes the ATM to cease operation.
- (h) ATM error indication (XLEERR) - A signal from the ATM to the PCDP. When ever the error detection logic circuits in the ATM indicate a disagreement between the recorded parity bits and the parity bits that are generated from the data during playback at either tape speed. The signal causes the ATM ERROR indicator on the PCDP to illuminate.
- (j) ATM running indication (XLRN) - A signal from the ATM which is transmitted to the PCDP five seconds after the ATM is commanded to operate in any mode. This signal illuminates the ATM RUN indicator on the PCDP whenever the tape is in motion. The signal is terminated when either end of the tape is reached.



# PROJECT GEMINI

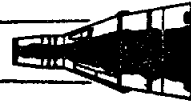

(k) Two mode controls (XHMSA1 and XHMSA2) - Mode control signals supplied to the computer from the AUX TAPE mode switch on the PCDP. The signals define the ATM mode selection.

<u>MODE POSITION</u>	<u>XHMSA1</u>	<u>XHMSA2</u>
AUTO	1	1
REPRO	0	1
All Others	0	0

## Pilots' Control and Display Panel (PCDP) (Figure 8-39)

The following CLD instruction programming is associated with the PCDP interface:

<u>Signal</u>	<u>Address</u>	
	<u>X</u>	<u>Y</u>
Computer mode 1	1	1
Computer mode 2	0	1
Computer mode 3	3	1
Start computation	1	2
Abort transfer	7	1
Fade-in discrete	6	1

# PROJECT GEMINI

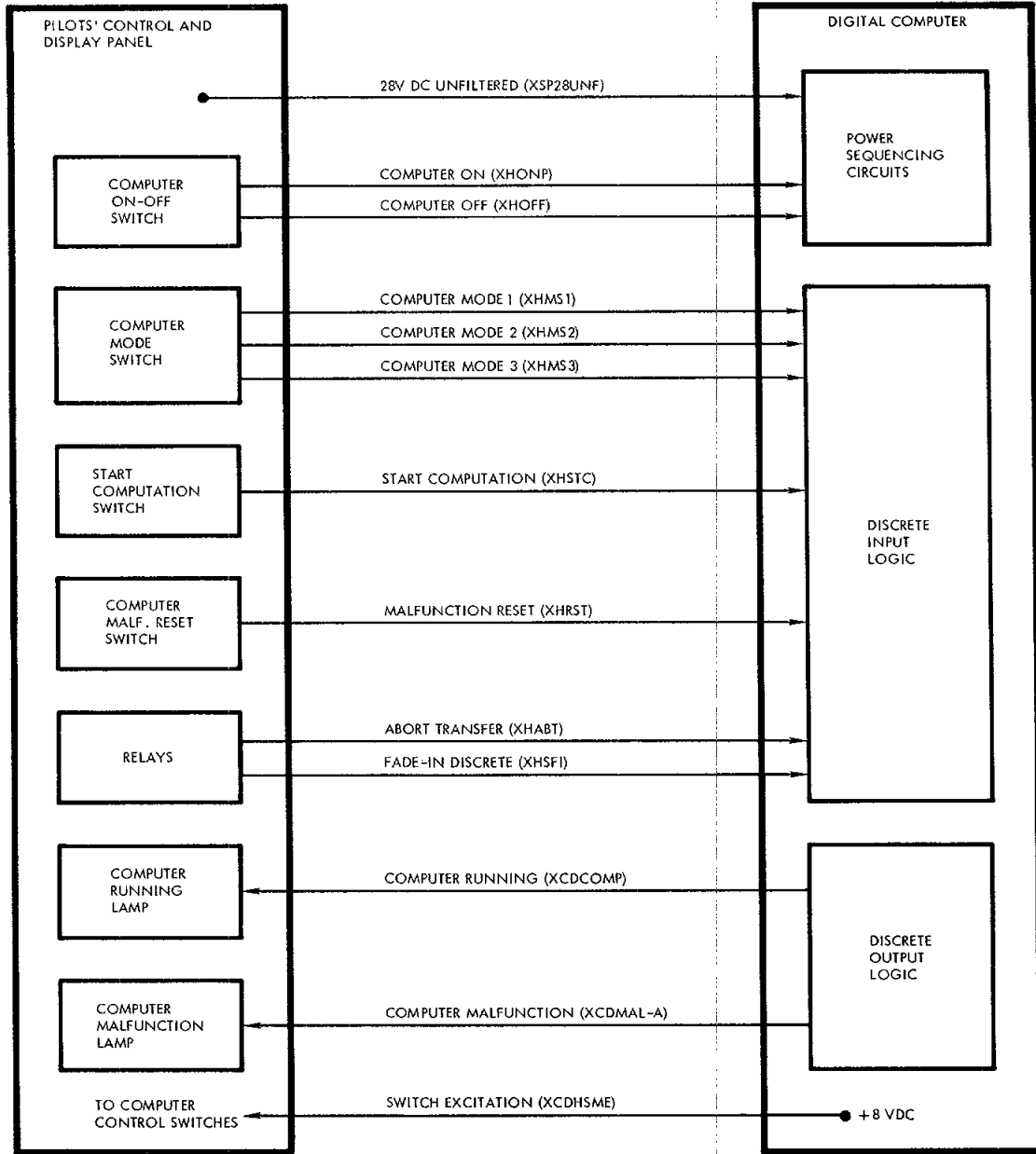

Figure 8-39 Computer-PCDP Interface



# PROJECT GEMINI



The following PRO instruction programming is associated with the PCDP interface:

<u>Signal</u>	<u>Address</u>	
	<u>X</u>	<u>Y</u>
Computer malfunction	4	3
Computer running	5	0
Reset start computation	2	6

The computer inputs from the PCDP are summarized as follows:

- (a) Computer on (XHONP) and computer off (XHOFF) - These signals from the COMPUTER ON-OFF switch control computer power.
- (b) Computer mode - The computer receives three binary coded discrete signals from the COMPUTER mode switch, to define the following operational modes:

<u>Mode</u>	Computer Mode 1 ( <u>XHMS1</u> )	Computer Mode 2 ( <u>XHMS2</u> )	Computer Mode 3 ( <u>XHMS3</u> )
Pre-launch	0	0	1
Ascent	0	1	0
Catch-up	0	1	1
Rendezvous	1	0	0
Re-entry	1	0	1

- (c) Start computation (XHSTC) - This signal from the START push-button switch starts the closed-loop rendezvous operation and initiates re-entry calculations.



# PROJECT GEMINI



- (d) Malfunction reset (XHRST) - This signal from the computer malfunction RESET switch resets the computer malfunction latch. The pilot uses the switch to test for a transient failure.
- (e) Abort transfer (XHABT) - The signal automatically switches the computer from the ascent mode to the re-entry mode.
- (f) Fade-in discrete (XHSFI) - This signal from a relay is supplied to the accumulator via the discrete input logic.
- (g) 28 vdc unfiltered (XSP28UMF)

The computer outputs to the PCDP are summarized as follows:

- (a) Computer running (XCDCOMP) - This program-controlled signal lights the computer running lamp which is used as follows:
  - (1) Pre-launch: The COMP (computer running) lamp remains off during this mode, except during mission simulation when its operation is governed by the mode being simulated.
  - (2) Ascent: The COMP lamp turns on following Inertial Platform release. The lamp remains on for the duration of the mode, and then turns off.
  - (3) Catch-up: The COMP lamp lights after the START push-button switch is depressed. The lamp remains on for the duration of the mode, and then turns off.



# PROJECT GEMINI

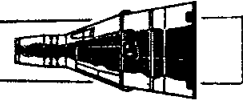

- (4) Rendezvous: The COMP lamp lights after the START push-button switch is depressed. For the remainder of the mode, operation of the lamp is dictated by the radar readings that occur in this mode. The lamp turns off when the mode is terminated.
- (5) Re-entry: The COMP lamp lights when the START push-button switch is depressed or when time to start re-entry calculations is equal to zero. The lamp remains on for the duration of the mode, and then turns off.
- (b) Computer malfunction (XCDMAL-A) - This signal turns on the computer MALF lamp. Either the computer diagnostic program, a built-in timing check, or an AGE command actuates the signal.
- (c) Switch excitation (SXDHSM) - This dc excitation is supplied to the COMPUTER mode switch, the START computation switch and the malfunction RESET switch.

## Incremental Velocity Indicator (IVI) (Figure 8-40)

The IVI contains three incremental velocity counters that display velocity increments along the spacecraft (body) axes.

Power is applied to the IVI whenever the computer is turned on. During the first 30-second period (or less) following the application of power, the IVI automatically references its counters to zero. After this period, the IVI is capable of recognizing computer signals.

# PROJECT GEMINI

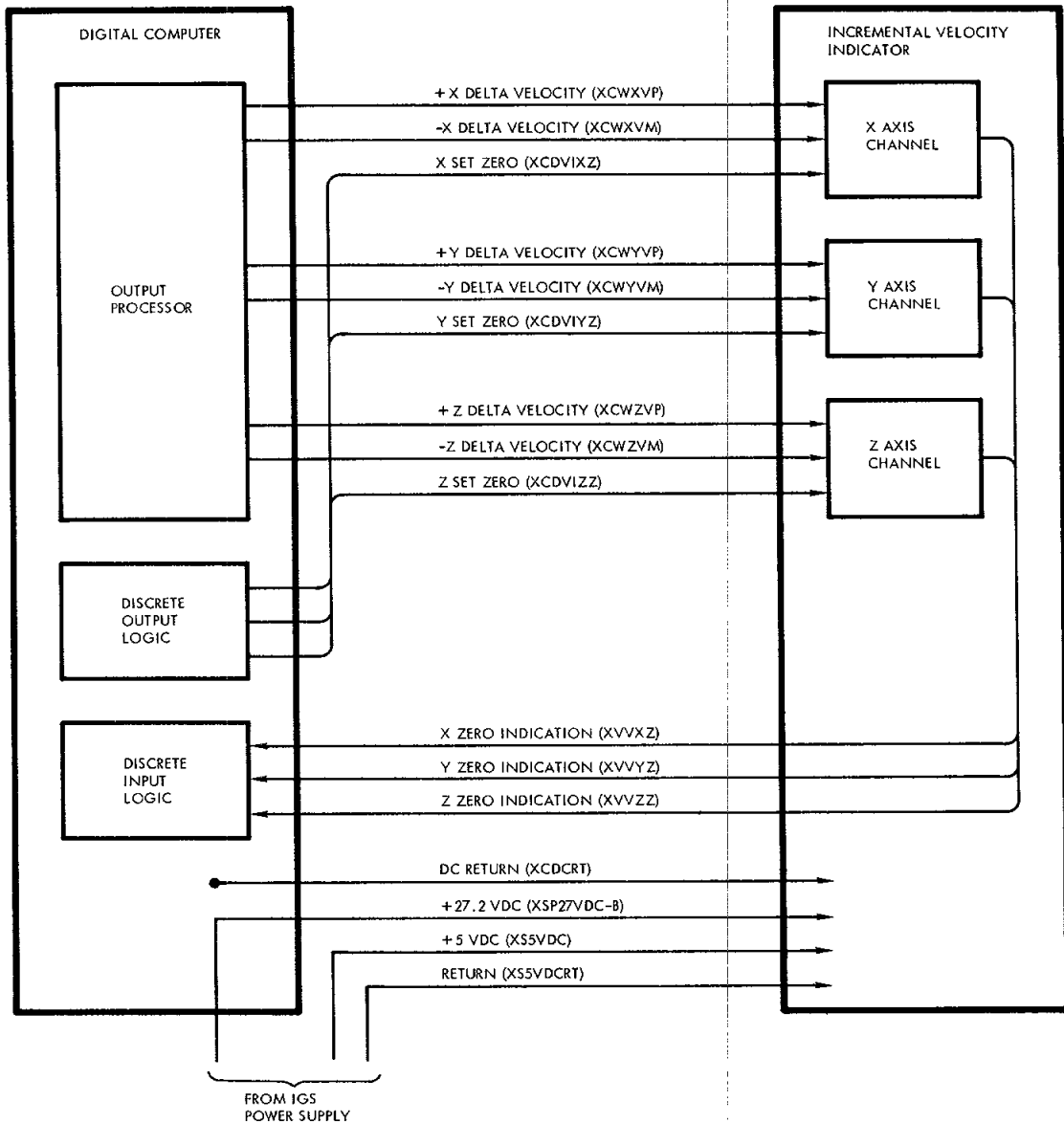
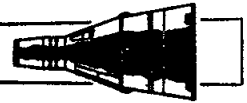

Figure 8-40 Computer-IVI Interface



# PROJECT GEMINI



The IVI counters can be set manually by means of control knobs on the front of the unit, or they can be set automatically by the computer. After the counters are initially set, they are driven by incremental velocity pulses from the computer. These pulses are used to update the indications displayed by the counter. The computer can set the individual counters to zero by providing a 20 usec pulse on each of three set zero lines. A feed-back signal, denoting zero counter position, permits the computer to test for the proper counter reference prior to the insertion and display of a computed velocity increment.

The following CLD instruction programming is associated with the IVI interface:

<u>Signal</u>	<u>X</u>	<u>Y</u>
X zero indication	1	3
Y zero indication	5	2
Z zero indication	6	2
Velocity error count not zero	2	2

The following PRO instruction programming is associated with the IVI interface:

<u>Signal</u>	<u>X</u>	<u>Y</u>
Select X counter	2	1
Select Y counter	3	1
Drive counters to zero	1	1
Write output processor	5	3



# PROJECT GEMINI



The computer supplies three signals to the IVI, one for each counter, that are used to position the counters to zero. To generate these signals, the program sets D011 minus and sets D012 and D013 as follows:

<u>Signal</u>	<u>D012</u>	<u>D013</u>
X set zero	Minus	Plus
Y set zero	Plus	Minus
Z set zero	Minus	Minus

The IVI provides three feed-back signals to the computer (D131, D125, and D126) to indicate that the counters are zeroed. The program tests the individual counters for zero position before attempting to drive them to zero.

The output processor provides a timed output to the IVI that represents velocity increments along the spacecraft axes. One output channel (phase 2) on the delay line is time-shared among the X, Y, and Z counters. Incremental velocities (in two's-complement form) are written on the delay line during phase 2 from accumulator bit positions 5, and 1 through 12. Discrete outputs D012 and D013, which are set no more than 1 ms before the PR035 operation, select the proper velocity signal as follows:

<u>Signal</u>	<u>D012</u>	<u>D013</u>
X velocity	Minus	Plus
Y velocity	Plus	Minus
Z velocity	Minus	Minus

Once data is written on the delay line, the output of the delay line is sensed for data during bit times BT1 through BT12. Any bit sensed during this time in-



# PROJECT GEMINI



dicates the presence of data which is then gated into a buffer along with the sign bit (BT13) during phase 2. This buffer is sampled approximately every 21.5 ms and a pulse is generated if the buffer is set either plus or minus. During this same time, an update cycle is initiated and a count of one is either added to or subtracted from the delay line data to decrease the magnitude by a count of one. If the buffer is set to zero during the update cycle, the data on the delay line is recirculated without affecting its magnitude. The zero output of the buffer is addressed as D122. When this discrete input is off, velocity data has been counted down to zero and the next velocity can be processed.

The computer inputs from the IVI are summarized as follows:

- (a) X zero indication (XVVXZ) - The down level signifies that the X channel of the IVI is at the zero position.
- (b) Y zero indication (XVYZ) - The down level signifies that the Y channel of the IVI is at the zero position.
- (c) Z zero indication (XVZZ) - The down level signifies that the Z channel of the IVI is at the zero position.

The computer outputs to the IVI are summarized as follows:

- (a) +X delta velocity (XCWXVP) - The up level denotes that the X channel should change by one foot per second in the fore direction.
- (b) -X delta velocity (XCWXVM) - The up level denotes that the X channel should change by one foot per second in the aft direction.



# PROJECT GEMINI



- (c) X set zero (XCDVIXZ) - The up level drives the X channel to the zero position.
- (d) +Y delta velocity (XCWYVP) - The up level denotes that the Y channel should change by one foot per second in the right direction.
- (e) -Y delta velocity (XCWYVM) - The up level denotes that the Y channel should change by one foot per second in the left direction.
- (f) Y set zero (XCDVIYZ) - The up level drives the Y channel to the zero position.
- (g) -Z delta velocity (XCWZVP) - The up level denotes that the Z channel should change by one foot per second in the down direction.
- (h) -Z delta velocity (XCWZVM) - The up level denotes that the Z channel should change by one foot per second in the up direction.
- (i) Z set zero (XCDVIZZ) - The up level drives the Z channel to the zero position.

## Instrumentation System (Figure 8-41)

The computer is interfaced with the multiplexer encoder unit and the signal conditioning equipment of the Instrumentation System. Continuous analog data is provided to the signal conditioning equipment, and stored digital quantities are sent upon request to the multiplexer encoder unit.

Certain computer data, as described below, is continually made available to the signal conditioning equipment. The signal conditioning equipment conditions this data for multiplexing and analog-to-digital conversion by the multiplexer encoder unit.

# PROJECT GEMINI

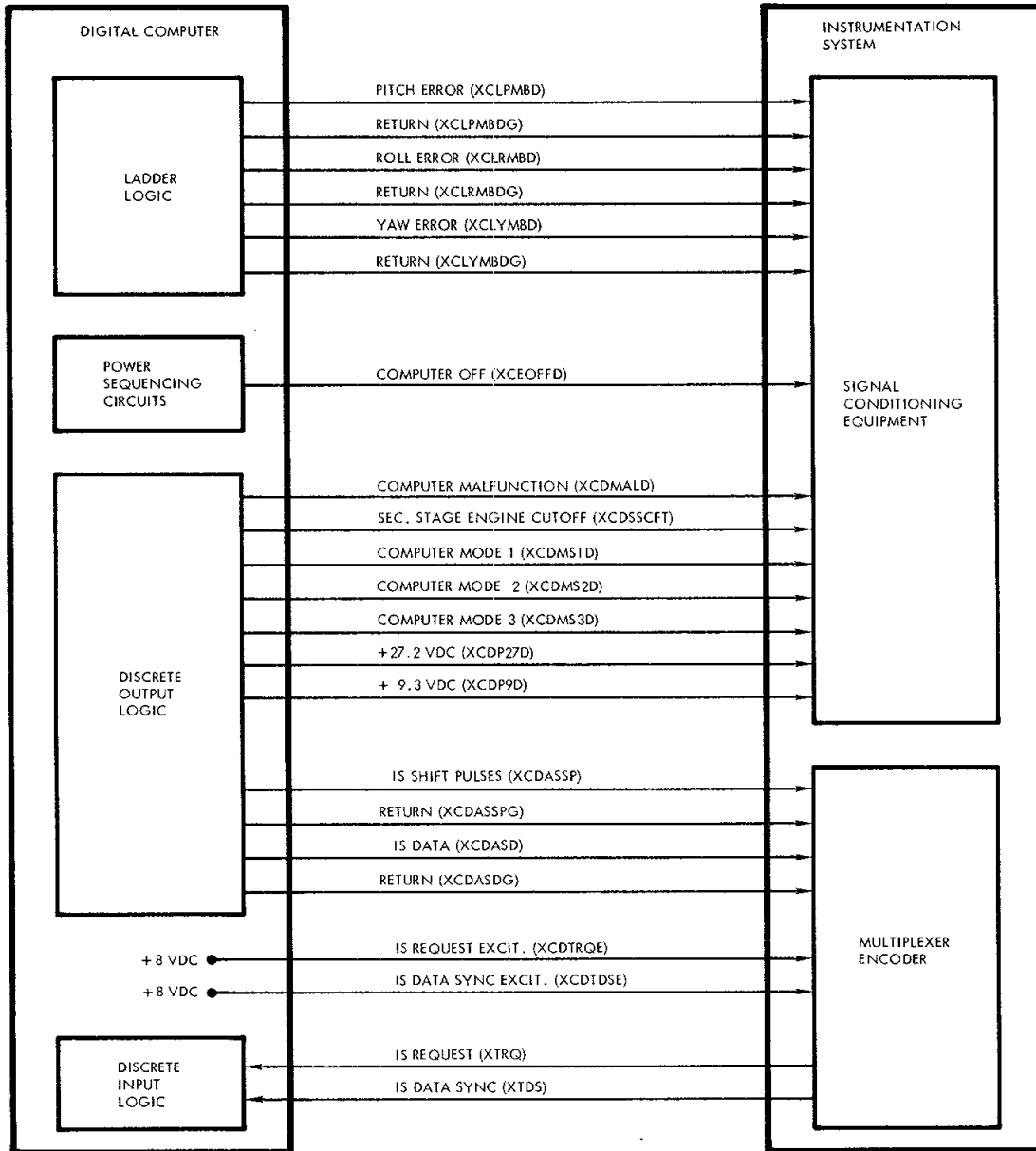
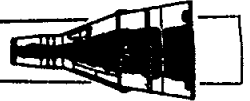

Figure 8-41 Computer-IS Interface



# PROJECT GEMINI



- (a) Computer modes - The mode signals transmitted to the computer are monitored to determine that the computer was in the correct mode for a particular operational mission phase.
- (b) Computer input power - The 27.2 vdc and 9.3 vdc inputs supplied to the computer by the IGS Power Supply are monitored via the computer.
- (c) Computer running - The computer running discrete output is monitored and recorded.
- (d) Computer malfunction - The computer malfunction discrete output is monitored and recorded.
- (e) Attitude errors: The pitch, yaw, and roll ac analog attitude errors are monitored and recorded.

Twenty-one data word locations in the computer memory are allocated for the storage of Instrumentation System data. Data stored in these locations is dependent upon the computer mode of operation.

The following CLD instruction programming is associated with the Instrumentation System interface:

<u>Signal</u>	<u>Address</u>	
	<u>X</u>	<u>Y</u>
Instrumentation System request	7	0
Instrumentation System sync	2	1

The following PRO instruction programming is associated with the Instrumentation System interface:



**PROJECT GEMINI**



<u>Signal</u>	<u>Address</u>	
	<u>X</u>	<u>Y</u>
Instrumentation System		
control gate	0	1

Every 50 ms or less, the computer program tests the Instrumentation System request discrete input (DIO7). If the discrete input is tested minus, the Instrumentation System sync discrete input (DI12) is tested as follows:

- (a) DI12 minus - The program stores current specified values, according to the computer mode, in an Instrumentation System memory buffer of 21 locations. The contents of the first buffer location are placed in the accumulator so that the sign position of the data word corresponds to the sign position of the accumulator. Then a PRO10 instruction is given. This instruction causes the information contained in accumulator bit positions S, and 1 through 23 to be supplied to the Instrumentation System. Twenty-four shift pulses are also supplied to the Instrumentation System.
- (b) DI12 plus - An Instrumentation System program counter is incremented by one and the contents of the next sequential buffer location are placed in the accumulator and sent to the Instrumentation System via the PRO10 instructions. Subsequent Instrumentation System requests advance the program counter until all 21 Instrumentation System quantities are transmitted.

The computer inputs from the Instrumentation System are summarized as follows:

- (a) Instrumentation System request (XTRQ) - An up level on this line



## PROJECT GEMINI



signifies that the Instrumentation System requires a computer data word. The word is transferred from the computer within 75 ms of the request. Requests can occur at rates up to 10 times per second.

- (b) Instrumentation System data sync (XTDS) - An up level on this line signifies the beginning of the Instrumentation System data transfer operation.

The computer outputs to the Instrumentation System are summarized as follows:

- (a) Instrumentation System shift pulses (XCDASSP) and return (SCDASSPG) - This series of  $2^4$  pulses causes Instrumentation System data to be transferred to the Instrumentation System buffer.
- (b) Instrumentation System data (SCDASD) and return (XCDASDG) - These  $2^4$  bits of data are transferred in synchronism with the Instrumentation System shift pulses.
- (c) Instrumentation System request excitation (SCDTRQE) - This +8 vdc signal is the excitation for the Instrumentation System request signal.
- (d) Instrumentation System data sync excitation (SCDTRQE) - This +8 vdc signal is the excitation for the Instrumentation System data sync signal.
- (e) Monitored signals - The following signals are supplied to the Instrumentation System for monitoring purposes:
  - (1) Pitch error (XCLPMBD) and return (XCLPMBDG)

# PROJECT GEMINI

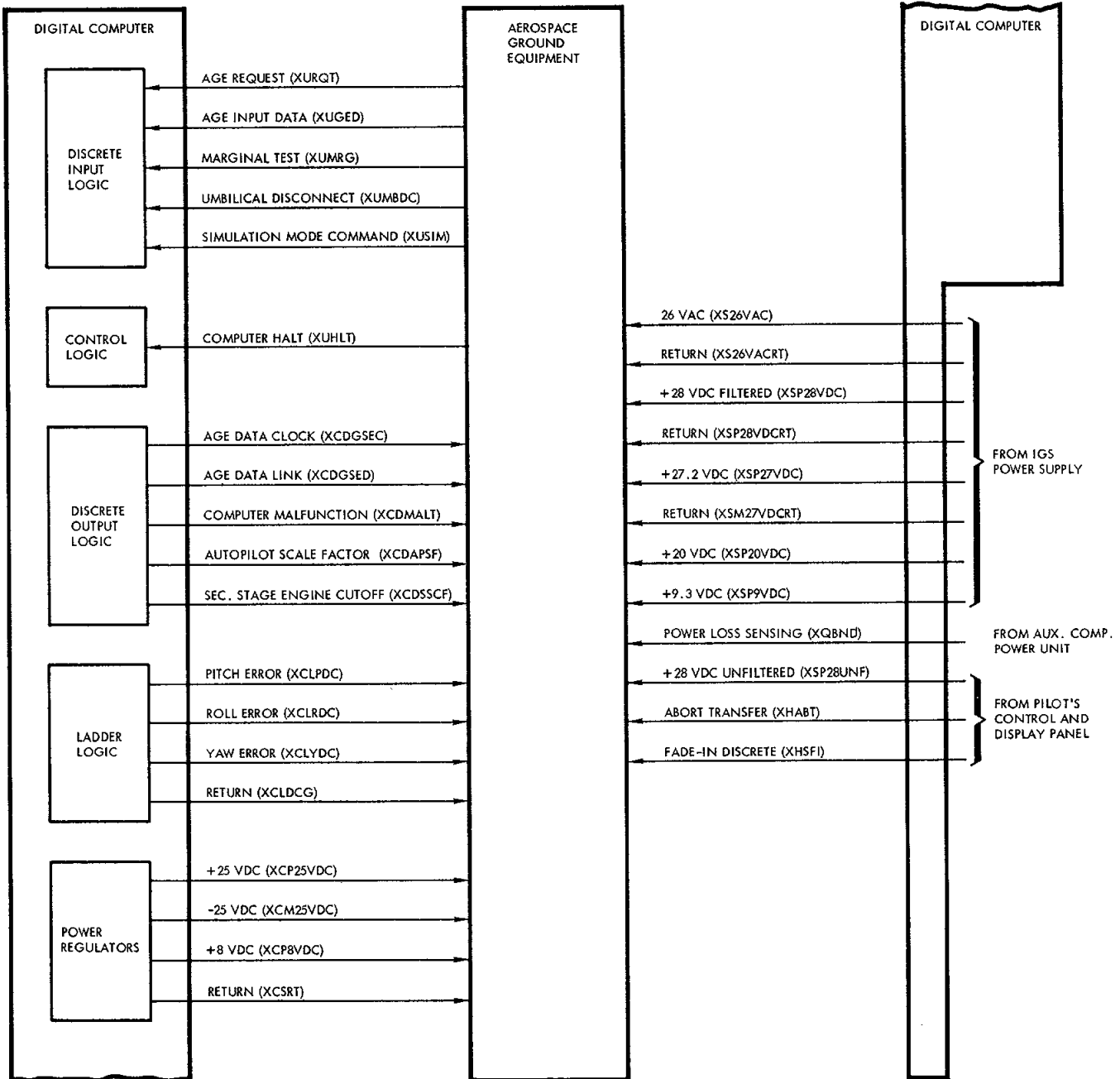

Figure 8-42 Computer-AGE Interface



# PROJECT GEMINI



- (2) Roll error (SCLRMBD) and return (XCLRMBDG)
- (3) Yaw error (XCLYMBD) and return (XCLYMBDG)
- (4) Computer off (XCEOFFD)
- (5) Computer malfunction (XCDMALD)
- (6) Second stage engine cutoff (XCDSSCFT)
- (7) Computer mode 1 (XCDMS1D)
- (8) Computer mode 2 (XCDMS2D)
- (9) Computer mode 3 (XCDMS3D)
- (10) +27.2 vdc (XCDP27D)
- (11) +9.3 vdc (XCDP9D)

## Aerospace Ground Equipment (AGE) Figure 8-42

The AGE determines spacecraft-installed computer status by being able to read and display the contents of any memory location, initiate and terminate marginal tests of the memory timing, and command the computer to condition the computer malfunction circuit. These tests are accomplished by a hard-wired computer/AGE data link.

In conjunction with a voice link to the spacecraft, the AGE can control the various computer modes of operation to determine the status of the computer and its interfaces. To aid in localizing failures, the AGE monitors the following computer signals:

- (a) All input and output voltages
  - (b) Second stage engine cutoff
  - (c) Autopilot scale factor
  - (d) Roll error command
  - (e) Yaw error command
  - (f) Pitch error command
  - (g) Computer malfunction
- } (to Titan Autopilot)

In addition, the AGE provides two hard-wired inputs to the computer to reset the malfunction circuit and halt the computer and to force a marginal check of the memory timing. Early and late strobing of the memory is effected using the com-



# PROJECT GEMINI



puter/AGE data link.

The following CLD instruction programming is associated with the AGE interfaces:

<u>Signal</u>	<u>Address</u>	
	<u>X</u>	<u>Y</u>
AGE request	2	3
AGE input data	7	2
Simulation mode command	4	2
Umbilical disconnect	6	3

The following PRO instruction programming is associated with the AGE interface:

<u>Signal</u>	<u>Address</u>	
	<u>X</u>	<u>Y</u>
AGE data link	2	2
AGE data clock	3	2
Computer malfunction	4	3
Memory strobe	0	6
Autopilot scale factor	1	6
Second stage engine cutoff	4	6

The AGE program commences when the AGE request (CI32) is tested minus. To receive the 18 bit AGE data word, the program repeats the following sequence of operations 18 times:

- (a) Turn on AGE data clock (D023)
- (b) Wait 2.5 ms



PROJECT GEMINI



- (c) Reset AGE data clock (D023)
- (d) Wait 1.5 ms
- (e) Read AGE input data (DI27)
- (f) Wait 1.5 ms

The above sequence causes the 18-bit AGE word to be shifted out of the AGE register and into the computer. The first 4 bits of the AGE word are mode bits, and the remaining 14 bits are data. The coding of the 4 mode bits is as follows:

<u>Mode Bits</u>				<u>Mode</u>
<u>4</u>	<u>3</u>	<u>2</u>	<u>1</u>	
0	0	0	0	None
0	0	0	1	Read any word
0	0	1	0	Set marginal early
0	0	1	1	Set computer malfunction on
0	1	0	0	Set marginal late
0	1	0	1	Set pitch ladder output
0	1	1	0	Set yaw ladder output
0	1	1	1	Set roll ladder output
1	0	0	0	Set all ladder outputs

In the read any word mode, the 14 data bits of the AGE word are as follows:

18	17	16	15	14	13	12	11	10	9	8	7	6	5
S5	S4	S3	S2	S1	A9	A8	A7	A6	A5	A4	A3	A2	A1

where A1 through A8 define the address of the requested data, A9 sets up AGE internal clock pulse timing, S1 through S4 define the sector of the requested



# PROJECT GEMINI



data, and S5 defines the syllable(s) of the requested data. The computer determines the requested data and sends it to the AGE. If the requested data is located in syllables 0 and 1, it is sent to the AGE starting with the high-order bit of syllable 1 and finishing with the low-order bit of syllable 0. If the requested data is located in syllable 2, the first 13 bits sent to AGE are 0's, and the last 13 bits are data from syllable 2 (high-order bit first). Requested data is sent to the AGE by executing the following sequence of operations 26 times. There is a delay of 4.5 ms between resetting clock 18 and setting clock 19.

- (a) Set AGE data link (D022) from accumulator sign position
- (b) Turn on AGE data clock (D023)
- (c) Wait 2.5 ms
- (d) Reset AGE data clock (D023)
- (e) Wait 2 ms
- (f) Reset AGE data link (D022)
- (g) Wait 1 ms

In the set marginal early mode, the computer sets D060 on. This signal, in conjunction with the marginal test signal provided by the AGE, causes early strobing of the computer memory.

In the set computer malfunction on mode, the computer sets D034 on to check the malfunction indication.

In the set marginal late mode, the computer sets D060 off. This signal, in conjunction with the marginal test signal, causes late strobing of the computer memory.



# PROJECT GEMINI



In the set ladder outputs modes, the 14 data bits of the AGE word are as follows:

18	17	16	15	14	13	12	11	10	9	8	7	6	5
S	D6	D5	D4	D3	D2	D1	0	0	0	0	0	0	0

where D1 through D6 are data bits and S is the sign bit. The data and sign bits are used to control the ladder output indicated by the 4 associated mode bits.

The number is in two's-complement form where D1 is the low-order data bit.

The computer inputs from the AGE are summarized as follows:

- (a) AGE request (XURQT) - An up level signifies that the AGE is ready to transfer a message to the computer.
- (b) AGE input data (XUGED) - An up level denotes a binary 1 being transferred from the AGE to the computer.
- (c) Marginal test (XUMRG) - An up level, in conjunction with the proper AGE message, causes the computer memory timing to be marginally tested.
- (d) Umbilical disconnect (XUMBDC) - An open circuit on this line signifies that the Inertial Platform has been released (or that the torquing signals have been removed). The Inertial Platform then enters the inertial mode of operation and the computer begins to perform the navigation guidance portion of its ascent routine.
- (e) Simulation mode command (XUSIM) - This command causes the computer to operate in a simulated mode as determined by the COMPUTER mode switch.



# PROJECT GEMINI



- (f) Computer halt (XUHLT) - An up level resets the computer malfunction circuit and sets the computer halt circuit.

The computer outputs to the AGE are summarized as follows:

- (a) AGE data clock (XCDGSEC) - This line reads out the AGE register and synchronizes the AGE with the AGE data link.
- (b) AGE data link (XCDGSED) - An up level denotes a binary 1 being transferred from the computer to the AGE.
- (c) Computer malfunction (XCDMALT) - An up level indicates that the computer malfunction latch is set. The latch can be set by the computer diagnostic program, a timing error, program looping, or an AGE command.
- (d) Monitored signals - The following signals and voltages are supplied to the AGE for monitoring or recording purposes:

- (1) Autopilot scale factor (XCDAPSF)
  - (2) Second stage engine cutoff (SCDSSCF)
  - (3) Pitch error (XCLPDC)
  - (4) Yaw error (XCLYDC)
  - (5) Roll error (XCLRDC)
  - (6) +25 vdc (XCP25VDC)
  - (7) -25 vdc (XCM25VDC)
  - (8) +8 vdc (XCP8VDC)
- } and common return (XCLDCG)
- } and common return (XCSRT)



# PROJECT GEMINI



- (9) 26 vac (XS26VAC) and return (XS26VACRT)
- (10) +28 vdc filtered (XSP28VDC) and return (XSP28VDCRT)
- (11) +28 vdc unfiltered (XSP28UNF)
- (12) +27.2 vdc (XSP27VDC)
- (13) -27.2 vdc return (XSM27VDCRT)
- (14) +20 vdc (XSP20VDC)
- (15) +9.3 vdc (XSP9VDC)
- (16) Power loss sensing (XQBND)
- (17) Abort transfer (XHABT)
- (18) Fade-in discrete (XHSFI)



# PROJECT GEMINI



## MANUAL DATA INSERTION UNIT

### SYSTEM DESCRIPTION

#### Purpose

The Manual Data Insertion Unit, hereinafter referred to as the MDIU, physically consists of the Manual Data Keyboard (Figure 8-43) and the Manual Data Readout (Figure 8-44), hereinafter referred to as the MDK and the MDR, respectively. The MDIU enables the pilot to insert data into, and read data from, the computer memory.

#### Performance

##### Data Insertion

Before data is set up for insertion into the computer, all existing data is cleared from the MDIU by pressing the CLEAR push-button switch on the MDR. Then the data insert push-button switches on the MDK are used to set up a 7-digit decimal number. The first two digits from the left specify the address of the computer memory location in which the data is to be stored, and the last five digits specify the data itself. As the data is set up, it is automatically supplied to the computer accumulator. A digit-by-digit verification of the address and data is made by means of the ADDRESS and MESSAGE display devices on the MDR. After verification, the ENTER push-button switch on the MDR is pressed to store the data in the selected memory location.

##### Data Readout

Before data is read from the computer, all existing data is cleared from the MDIU by pressing the CLEAR push-button switch. Then the data insert push-

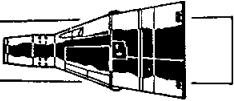
 **PROJECT GEMINI** 

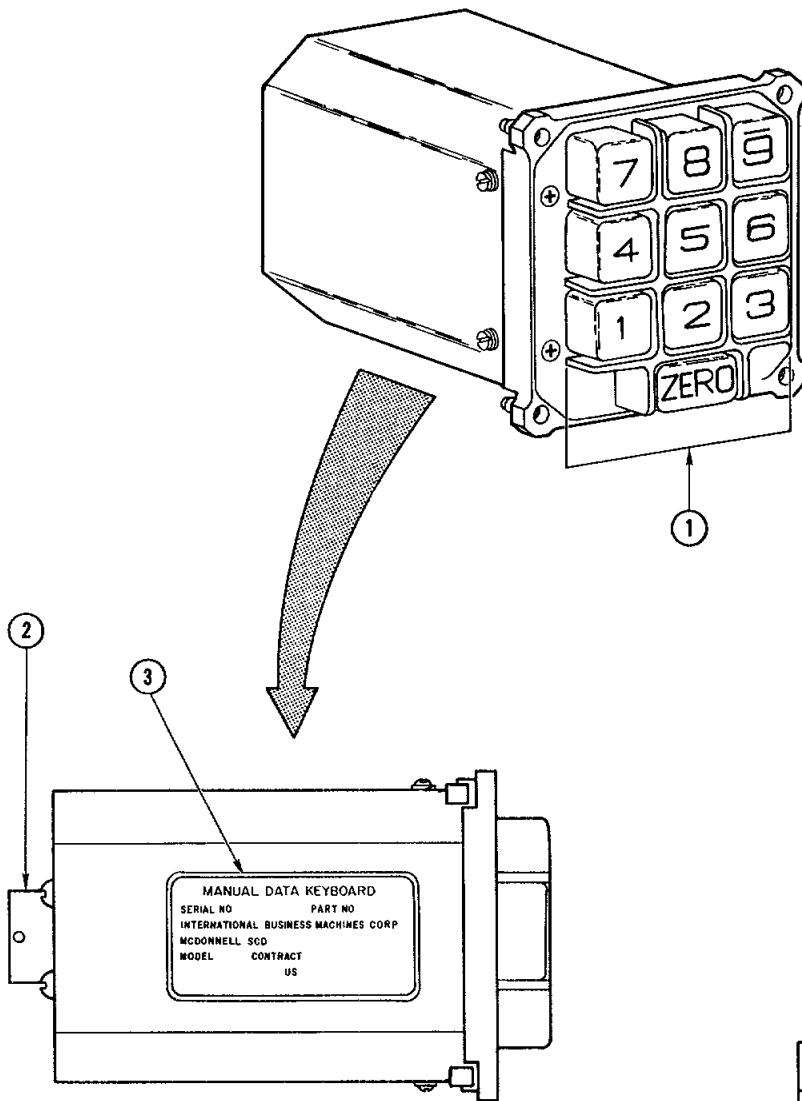

LEGEND	
ITEM	NOMENCLATURE
①	DATA INSERT PUSH-BUTTON SWITCHES
②	CONNECTOR J1
③	IDENTIFICATION PLATE

Figure 8-43 Manual Data Keyboard

PROJECT GEMINI

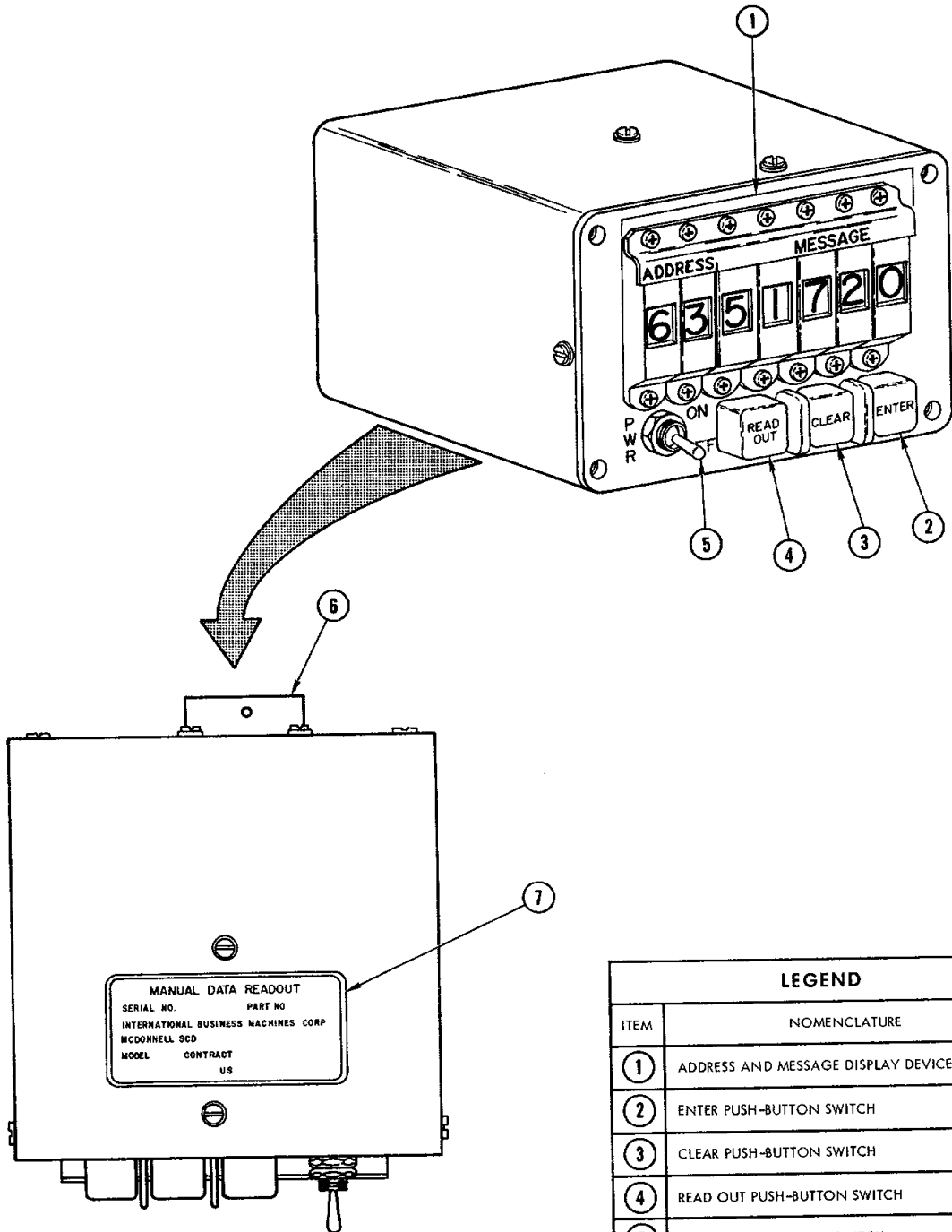

LEGEND	
ITEM	NOMENCLATURE
①	ADDRESS AND MESSAGE DISPLAY DEVICES
②	ENTER PUSH-BUTTON SWITCH
③	CLEAR PUSH-BUTTON SWITCH
④	READ OUT PUSH-BUTTON SWITCH
⑤	PWR (POWER) TOGGLE SWITCH
⑥	CONNECTOR J1
⑦	IDENTIFICATION PLATE

Figure 8-44 Manual Data Readout



# PROJECT GEMINI



button switches are used to set up a 2-digit decimal number. The two digits specify the address of the computer memory location from which data is to be read. A digit-by-digit verification of the address is made by means of the ADDRESS display devices. After verification, the READ OUT push-button switch on the MDR is pressed and the data is read from the selected memory location and displayed by the MESSAGE display devices.

### MDK Physical Description

The MDK is 3.38 inches wide, and 5.51 inches deep. It weighs 1.36 pounds. External views of the MDK are shown on Figure 8-43. The major external characteristics are summarized in the accompanying legend.

### MDR Physical Description

The MDR is 3.26 inches high, 5.01 inches wide, and 6.41 inches deep. It weighs 3.15 pounds. External views of the MDR are shown on Figure 8-44. The major external characteristics are summarized in the accompanying legend.

### Controls and Indicators

The controls and indicators located on the MDK and MDR are illustrated on Figure 8-45. The accompanying legend identifies the controls and indicators, and describes their purposes.

## SYSTEM OPERATION

### Power

The MDIU receives all of the power required for its operation from the computer. This power consists of the following regulated dc voltages:

PROJECT GEMINI

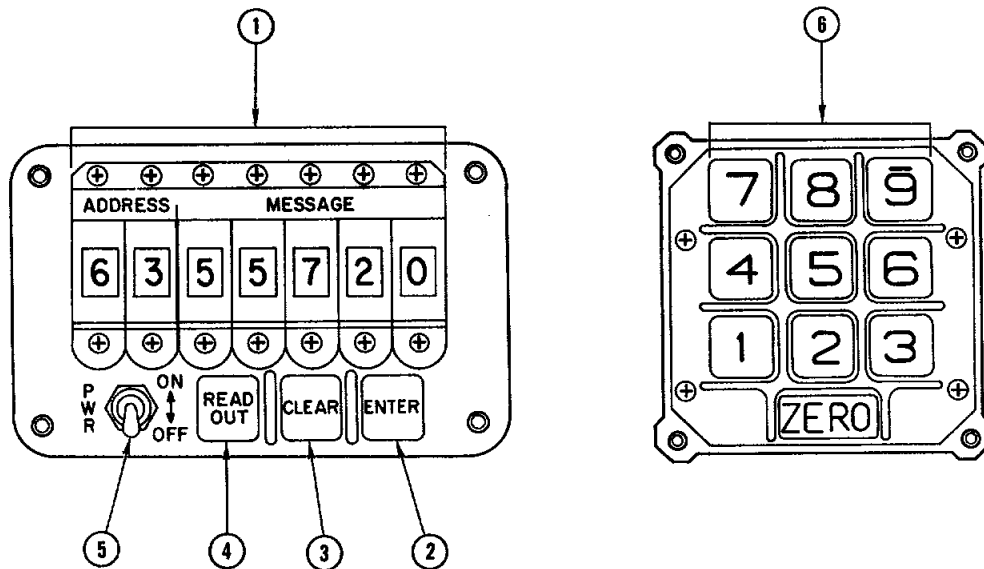

LEGEND		
ITEM	NOMENCLATURE	PURPOSE
①	ADDRESS AND MESSAGE DISPLAY DEVICES	DISPLAY ADDRESS AND MESSAGE SENT TO COMPUTER DURING ENTER OPERATION; DISPLAY ADDRESS SENT TO, AND MESSAGE RECEIVED FROM, COMPUTER DURING READOUT OPERATION.
②	ENTER PUSH-BUTTON SWITCH	PROVIDES MEANS FOR CAUSING MESSAGE SENT TO COMPUTER DURING ENTER OPERATION TO BE STORED IN MEMORY.
③	CLEAR PUSH-BUTTON SWITCH	PROVIDES MEANS FOR CAUSING ADDRESS AND MESSAGE SET UP BY MDK TO BE CLEARED OR CANCELED.
④	READ OUT PUSH-BUTTON SWITCH	PROVIDES MEANS FOR CAUSING MESSAGE TO BE READ OUT OF COMPUTER AND DISPLAYED BY MESSAGE DISPLAY DEVICES.
⑤	PWR (POWER) TOGGLE SWITCH	PROVIDES MEANS FOR CONTROLLING APPLICATION OF POWER TO MDK AND MDR.
⑥	DATA INSERT PUSH-BUTTON SWITCHES	PROVIDE MEANS FOR CAUSING ADDRESS AND MESSAGE TO BE SENT TO COMPUTER AND TO BE DISPLAYED BY ADDRESS AND MESSAGE DISPLAY DEVICES.

Figure 8-45 Manual Data Insertion Unit Front Panels



# PROJECT GEMINI



- (a) +25 vdc
  - (b) -25 vdc
  - (c) +8 vdc and return
- } and common return

This power is available at the MDIU whenever the computer is turned on. However, it is not actually applied to the MDIU circuits until the PWR switch on the MDR is turned on. When power is turned on at the MDR, the regulated dc voltages are filtered by a capacitor network and supplied to the MDK and MDR circuits.

### MDK Data Flow (Figure 8-46)

The MDK has ten data insert push-button switches. These switches are used to select the address of a computer memory location in which data is to be stored or from which data is to be read. For storing data, the push-button switches are numbered decimally, the insert button encoder is used to convert their outputs to binary coded decimal values that can be used by the computer. These values, called the insert data signals, are supplied to the insert serializer in the computer. The insert button encoder also develops the data available signal which is supplied to the discrete input logic of the computer.

### MDR Data Flow (Figure 8-47)

The MDR has seven digital display devices and three command push-button switches. The display devices are used to display the address set up by the data insert push-button switches on the MDK, and to display either the data set up by the data insert push-button switches or the data read from a computer memory location. The command push-button switches, called ENTER, READ OUT, and CLEAR, are used to determine whether data is entered into or read out of the computer, or whether the data that has been set up is to be cleared (or canceled). These push-button switches all supply inputs to the discrete input logic of the computer. Since

# PROJECT GEMINI

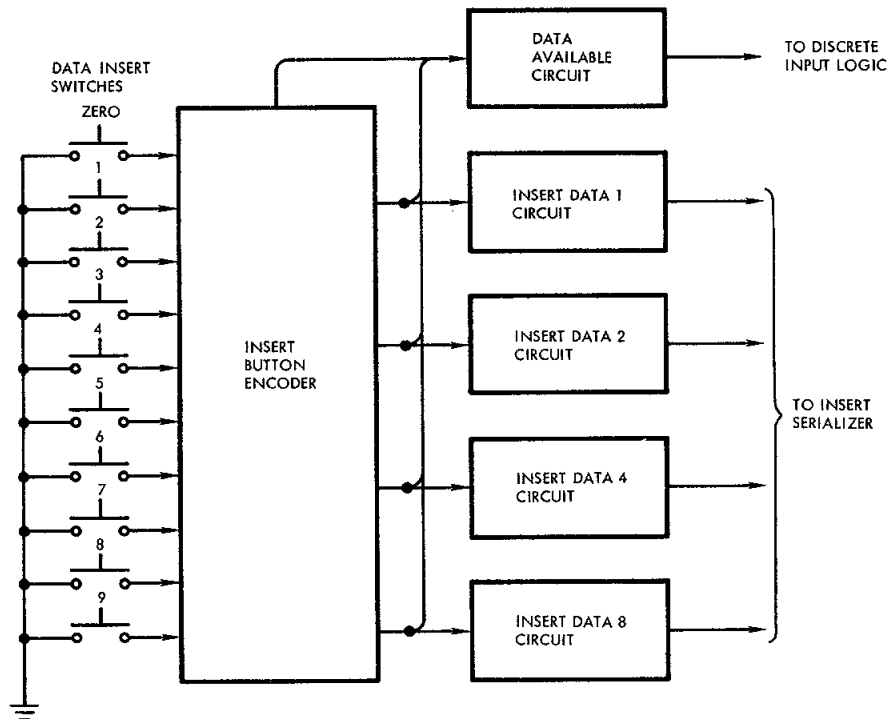

Figure 8-46 Manual Data Keyboard Data Flow

# PROJECT GEMINI

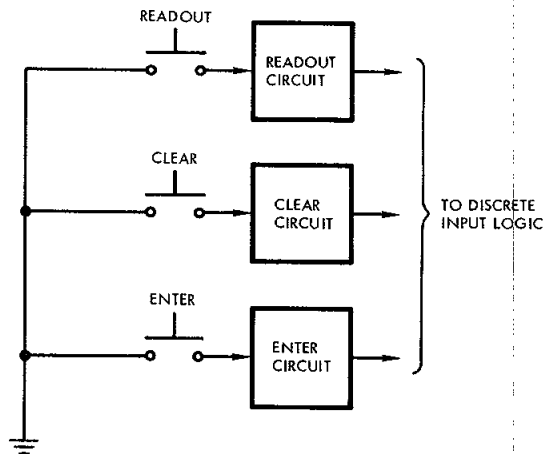
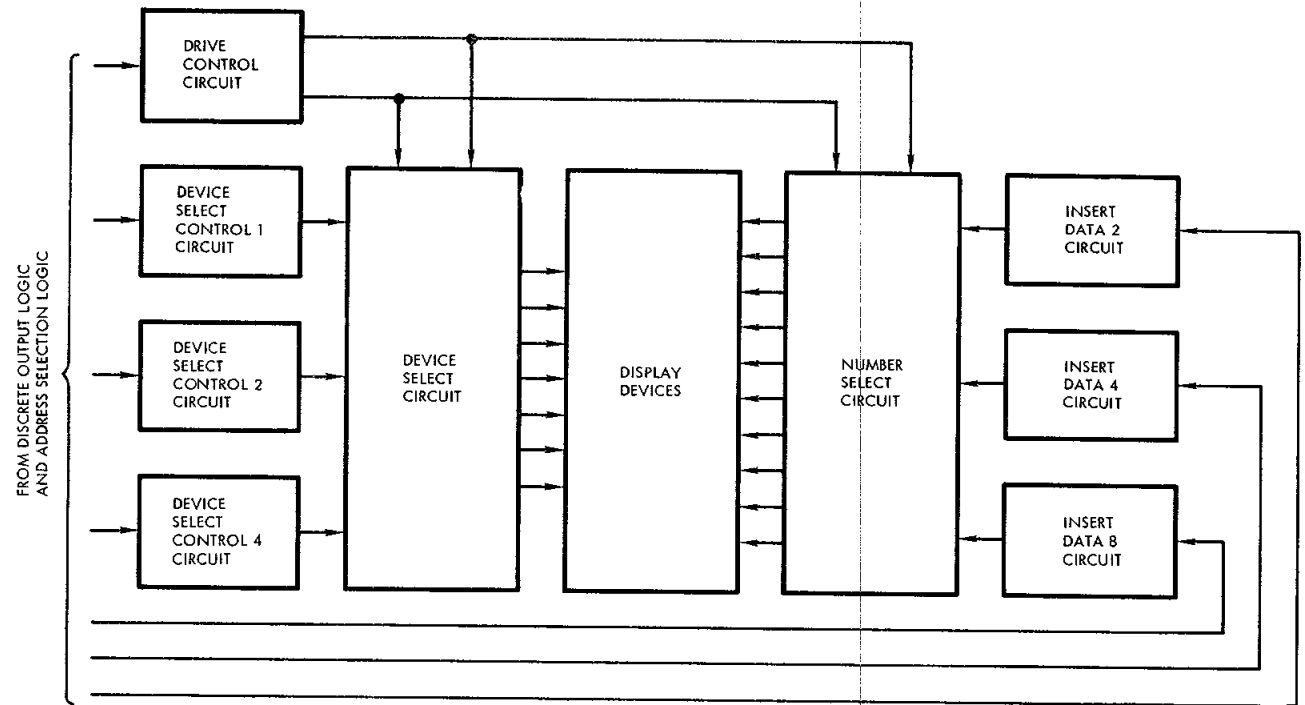

Figure 8-47 Manual Data Readout Data Flow



## PROJECT GEMINI



the display devices provide a decimal display, the binary coded decimal values received from the computer must be decoded before they can be displayed. These values from the computer are supplied to three device select control circuits and three insert data circuits. Another signal from the computer is supplied to the display device drive control circuit. A combination of outputs from the device select control circuits is used in conjunction with the outputs of the display device drive control circuit to select a particular display device. This selection is accomplished by means of the device selector. A combination of outputs from the insert data circuits is used in conjunction with the outputs of the display device drive control circuit to select a particular number on the selected display device. This selection is accomplished by means of the number selector. Thus, through the combined operations of the device selector and the number selector, the binary coded decimal values received from the computer are decoded and an equivalent decimal display is presented on the display devices.

### Manual Data Subroutine

The manual data subroutine, which determines when data is transferred between the MDIU and the computer, is described under the Operational Program heading in the DIGITAL COMPUTER SYSTEM OPERATION part of this section.

### Interfaces

The MDIU interfaces, all of which are made with the computer, are described under the Interfaces heading in the DIGITAL COMPUTER SYSTEM OPERATION part of this section.



# PROJECT GEMINI



## AUXILIARY TAPE MEMORY

### SYSTEM DESCRIPTION

#### General

The Auxiliary Tape Memory (ATM) is a self-contained magnetic tape recording system. It is used in spacecraft eight through twelve to provide additional program storage for the digital computer. It has a total storage capacity of over 85,000 thirteen-bit words. This is about seven times that of the computer core memory. The ATM is mounted on a cold plate in the adapter section of the spacecraft (Figure 8-15).

#### Physical Characteristics

The ATM is 10 inches x 10 inches x 7 inches and weighs 25.7 pounds (Figure 8-48). It has three external connectors for its interfaces with the digital computer and the Pilots' Display and Control Panel (PCDP). The ATM is hermetically sealed with initial pressurization of one atmosphere, gage, at ambient room temperature and pressure.

Internally, the ATM contains a tape transport, a drive motor, and the necessary electronics for the read, write and control functions.

#### Functional Characteristics

The functional characteristics of the ATM are summarized as follows:

Tape length	525 feet
Tape type	3M type IR-1353 Heavy-duty, high resolution Instrumentation tape
Tape speed	Read/write - 1.5 ips $\pm 0.5\%$ Wind/rewind - 8 times r/w speed

# PROJECT GEMINI

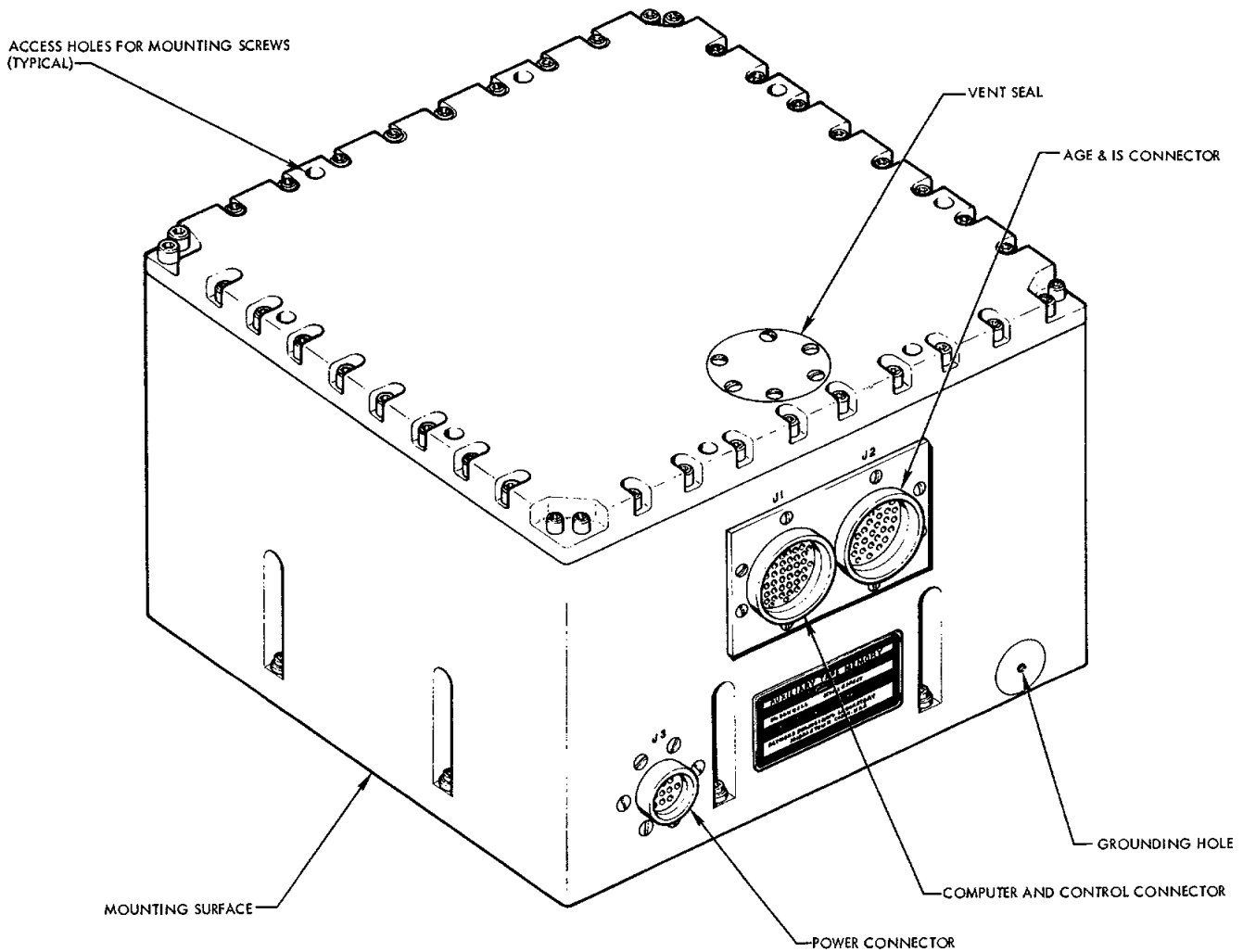
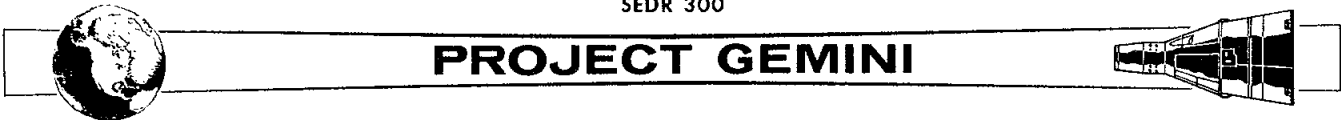

Figure 8-48 Auxiliary Tape Memory



# PROJECT GEMINI



Channels	16 (9 data, 3 parity, 3 clock, 1 spare)
Storage capacity	Total $12.5 \times 10^6$ bits (15 channels) Effective 90,000 13-bit computer words
Storage density	133 bits/inch/channel
Data transfer rate	600 bits/second
Ready time-per max program	10 minutes (verify 3 syllables) 7 minutes (reprogram 2 syllables)
Total read time	67 minutes
Total wind/rewind time	10 minutes max.
Voltage	21 - 30 vdc
Voltage interrupts	115 milliseconds

## Controls and Indicators

The controls and indicators associated with the ATM are summarized as follows:

- (a) AUX TAPE OFF - ON/RESET - A toggle switch on the PCDP, used to apply power to the ATM or to reset it.
- (b) AUX TAPE mode selector - A five - position rotary switch used to select an operational control mode for the ATM. The five modes are: (1) STDBY, (2) AUTO, (3) WIND, (4) REWIND and (5) PROG (reprogram).
- (c) Manual Data Insertion Unit (MDIU) - Used to select one of three ATM operational sequences stored in the computer memory. These are: (1) reprogram, (2) verify, and (3) reprogram/verify.



# PROJECT GEMINI



- (d) Incremental Velocity Indicator (IVI) - Display tape position words (on the IVI LEFT/RIGHT channel) and module words (on the IVI FORE/AFT channel) during the ATM search operation.
- (e) AUX TAPE RUN indicator - A lamp on the PCDP which illuminates whenever ATM motor power is applied.
- (f) AUX TAPE ERROR indicator - A lamp on the PCDP which illuminates when incorrect frame parity is detected by the ATM.

## SYSTEM OPERATION

### General

The ATM is used to store operational program modules for in-flight loading of the spacecraft digital computer. It is capable of replacing the majority of the data in syllables zero and one of the computer memory (approx 8,000 thirteen-bit words) in approximately seven minutes.

The program data is stored in the ATM by recording it on magnetic recording tape. Normally, this data is supplied by the Aerospace Ground Equipment (AGE) and re-corded (written) on the tape prior to launch time. It is also possible, however, to write data onto the tape using the MDIU and digital computer.

There are two methods of loading the computer memory from the ATM. The first is the auto mode and is considered to be the primary one. The second is the manual mode and is provided as a back-up method for loading the computer memory. The basic difference between the two is that the auto mode requires fewer manual operations.



# PROJECT GEMINI



## Tape Transport

The ATM employs a reel-to-reel peripheral drive transport assembly and a single-combination read/write head having 16 tracks with two windings per track. The drive motor accomplishes speed reversal by using a solid-state switch to switch the phase of one winding with respect to the other. A tape speed of 1.5 ips (nominal) is provided for both read and write modes of operation. High speed wind/rewind operation is accomplished by supplying the drive motor with a frequency and voltage which are eight times those used for the read/write speed. The drive system power is provided by a dc-to-dc inverter and a fixed frequency oscillator. The oscillator output provides the frequency for high-speed operation. The frequency for the read/write speed originates from this same source but it is reduced by 8:1 through a binary chain.

## Write Electronics

Figure 8-49 shows the ATM write electronics. The ATM input accepts four-bit NRZ (Non-Return-to-Zero) data in serial form (one bit in each four-bit frame is a parity bit) together with shift pulses and frame synchronizing clock pulses. The recording circuits convert the serial input into parallel form and record the four-bit frames in parallel NRZ format on the magnetic tape. Each four-bit frame plus a frame synchronizing clock pulse is recorded redundantly on the magnetic tape by triple redundant head drivers. Each data bit is spread across the tape width to minimize errors introduced by tape flaws or foreign matter on the tape surface.

## Read Electronics

The play-back (read) electronics (Figure 8-50) uses the same tape head as the write electronics. Each data channel is read by a play-back amplifier/level

# PROJECT GEMINI

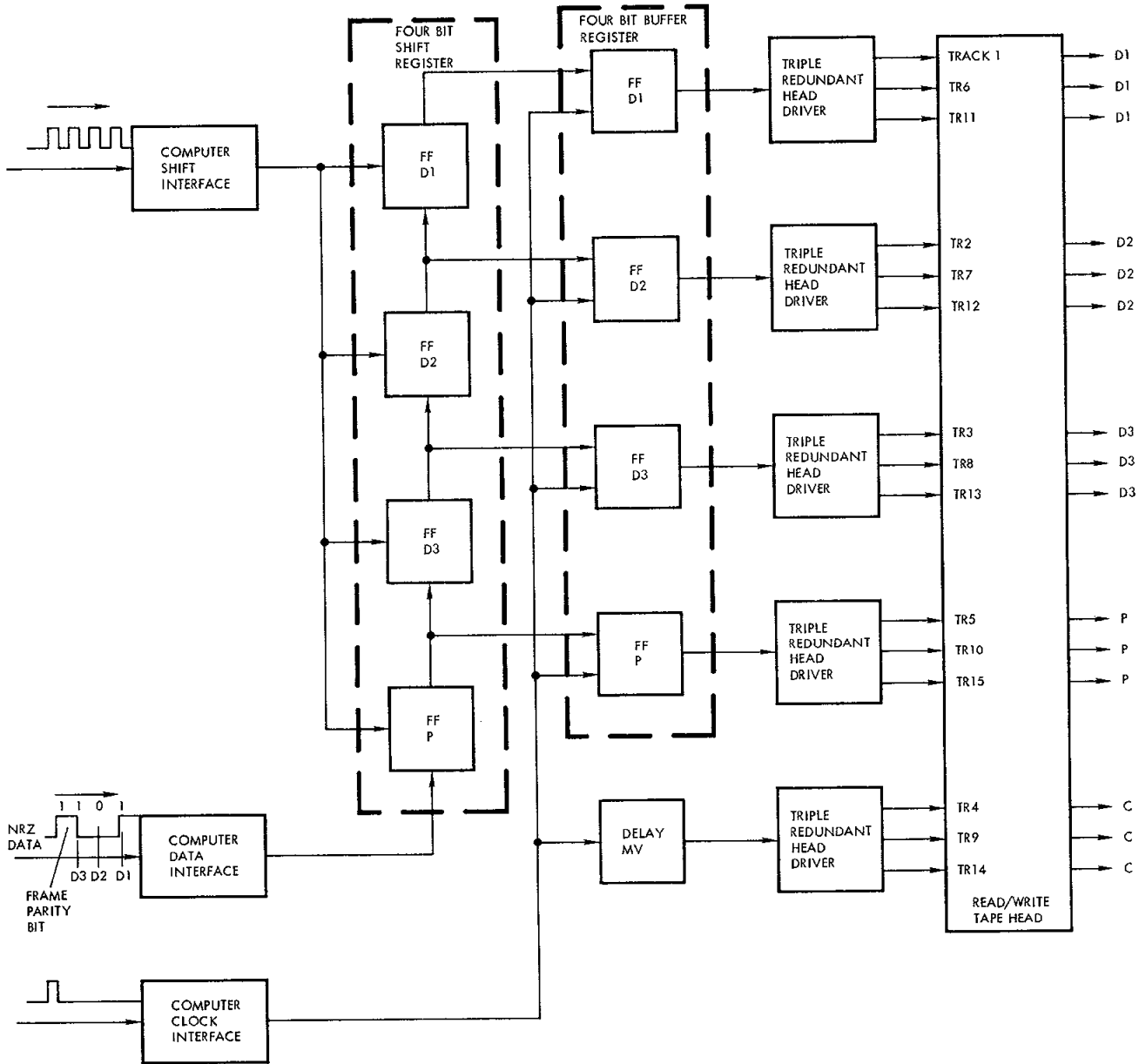
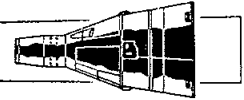

Figure 8-49 ATM Write Electronics Block Diagram

# PROJECT GEMINI

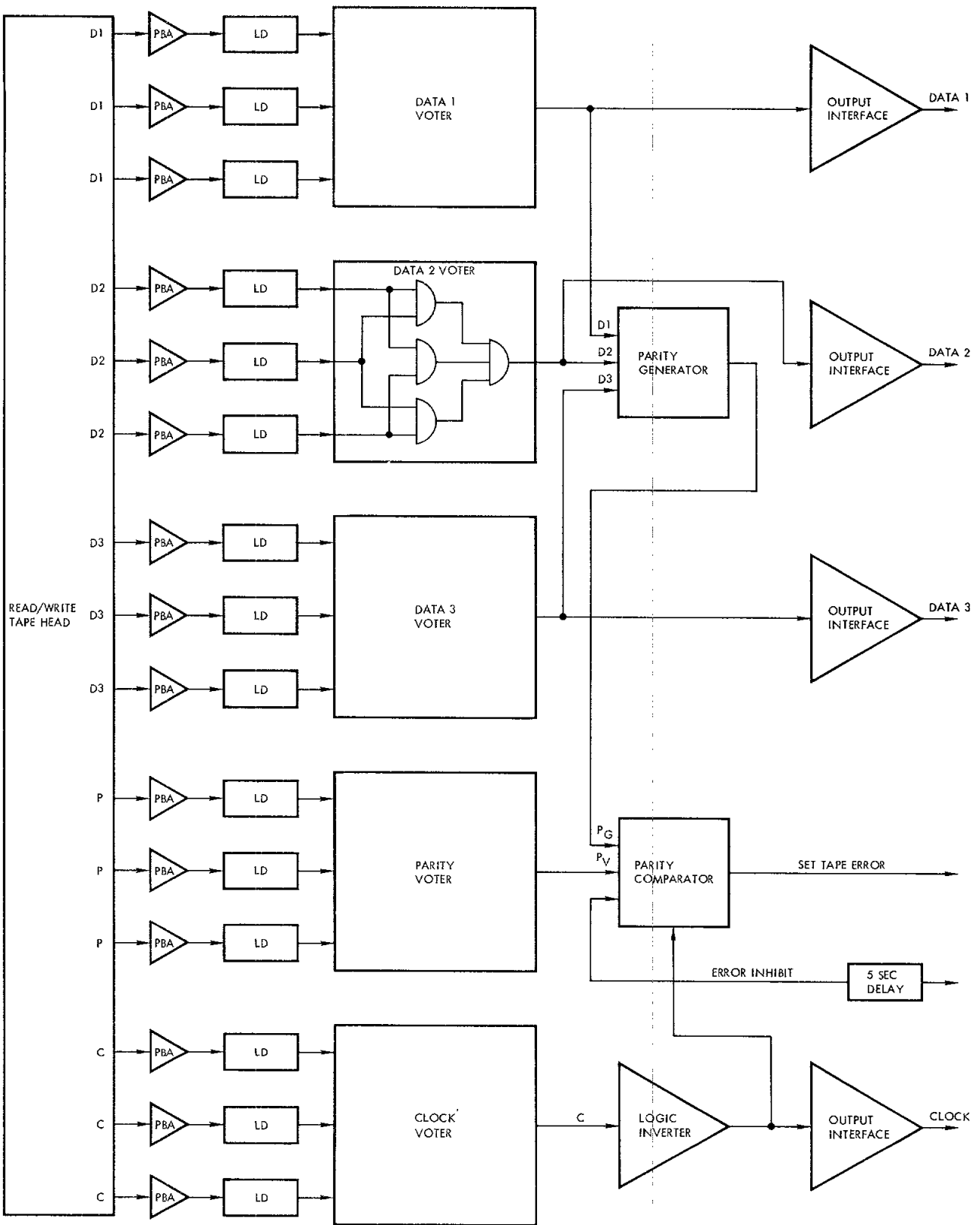
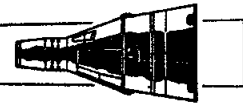

Figure 8-50 ATM Read Electronics Block Diagram



# PROJECT GEMINI



detector, and each redundantly recorded data bit ( $D_1$ ,  $D_2$ ,  $D_3$ , P, C) is majority voted on (2 out of 3 majority vote) by the ATM voting logic. Three voted outputs ( $D_1$ ,  $D_2$ , and  $D_3$ ) and clock voters are supplied to output interface amplifiers and, subsequently, to the digital computer (the parity bit is not supplied to the computer). Each data voter output is also supplied to a parity generator. The output of the parity generator is then compared with the voted-on parity bit read from the tape. If the recorded parity bit differs from the generated parity bit, the ATM issues an ATM error discrete which will illuminate the AUX TAPE ERROR lamp on the PCDP. A check for tape errors is also performed during the wind and rewind modes of operation by comparing the recorded parity bits with those developed from the voted data bits during playback.

## INTERFACES

The ATM interfaces with the digital computer and the PCDP are described in the DIGITAL COMPUTER INTERFACES part of this section.



# PROJECT GEMINI



## INCREMENTAL VELOCITY INDICATOR

### SYSTEM DESCRIPTION

#### Purpose

The primary purpose of the Incremental Velocity Indicator (Figure 8-51), hereinafter referred to as the IVI, is to provide visual indications of incremental velocity for the longitudinal (forward-aft), lateral (left-right), and vertical (up-down) axes of the spacecraft. These indicated incremental velocities represent the amount and direction of additional velocity or thrust necessary to achieve correct orbit, and thus are added to the existing spacecraft velocities by means of the maneuver thrusters.

An additional use of the IVI is to display the tape position words and module words from the Auxiliary Tape Memory during its operation. Additional information concerning this usage can be found in the AUXILIARY TAPE MEMORY SYSTEM OPERATION part of this section.

#### Performance

A three-digit decimal display device and two direction indication lamps are used to display incremental velocity for each of the three spacecraft axes. Both the lamps and the display devices can be set up either manually by rotary switches on the IVI or automatically by inputs from the computer. Then, as the maneuver thrusters correct the spacecraft velocities, pulses are received from the computer which drive the display devices toward zero. If a display device is driven beyond zero, indicating an overcorrection of the spacecraft velocity for the respective axis, the opposite direction indication lamp lights and the display device indication increases in magnitude to show a velocity error in the opposite direction.

PROJECT GEMINI

LEGEND	
ITEM	NOMENCLATURE
①	FWD (FORWARD) DIRECTION INDICATION LAMP
②	FORWARD-AFT DISPLAY DEVICE
③	L (LEFT) DIRECTION INDICATION LAMP
④	LEFT-RIGHT DISPLAY DEVICE
⑤	R (RIGHT) DIRECTION INDICATION LAMP
⑥	UP-DOWN DISPLAY DEVICE
⑦	UP DIRECTION INDICATION LAMP
⑧	DN (DOWN) DIRECTION INDICATION LAMP
⑨	DN-UP ROTARY SWITCH
⑩	L-R ROTARY SWITCH
⑪	AFT-FWD ROTARY SWITCH
⑫	AFT DIRECTION INDICATION LAMP
⑬	IDENTIFICATION PLATE
⑭	CONNECTOR J1

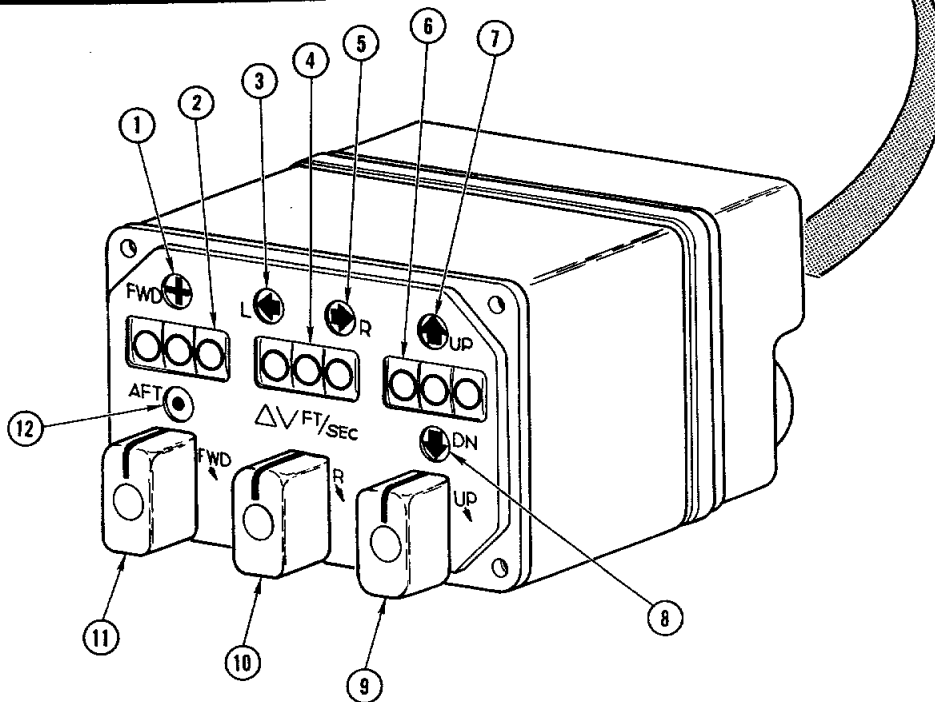
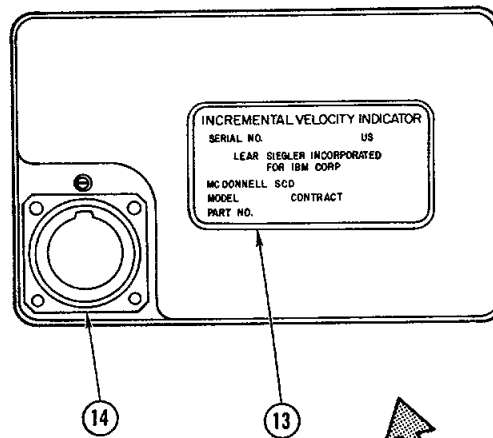

Figure 8-51 Incremental Velocity Indicator



# PROJECT GEMINI



## Physical Description

The IVI is 3.25 inches high, 5.05 inches wide, and 5.89 inches deep. It weighs 3.25 pounds. The major external characteristics are shown in Figure 8-51 and summarized in the accompanying legend.

## Controls and Indicators

The controls and indicators located on the IVI are illustrated on Figure 8-52. The accompanying legend identifies the controls and indicators, and describes their purposes.

## SYSTEM OPERATION

### Power

The power required for operation of the IVI is supplied by the IGS Power Supply whenever the computer is turned on. The power inputs are as follows:

- (a) +27.2 vdc and return
- (b) +5 vdc and return

During the first 30 seconds (or less) following the application of power, the incremental velocity counters on the IVI are automatically driven to zero. Thereafter, the IVI is capable of normal operation.

### Basic Operation

The IVI includes three identical channels, each of which accepts velocity error pulses for one of the spacecraft axes and processes them for use by a decimal display device and its two associated direction indication lamps. The velocity error pulses are either received from the computer or generated within the IVI, as determined by the position of the rotary switch associated with each channel. With the spring-loaded switches in their neutral center positions, the IVI

PROJECT GEMINI

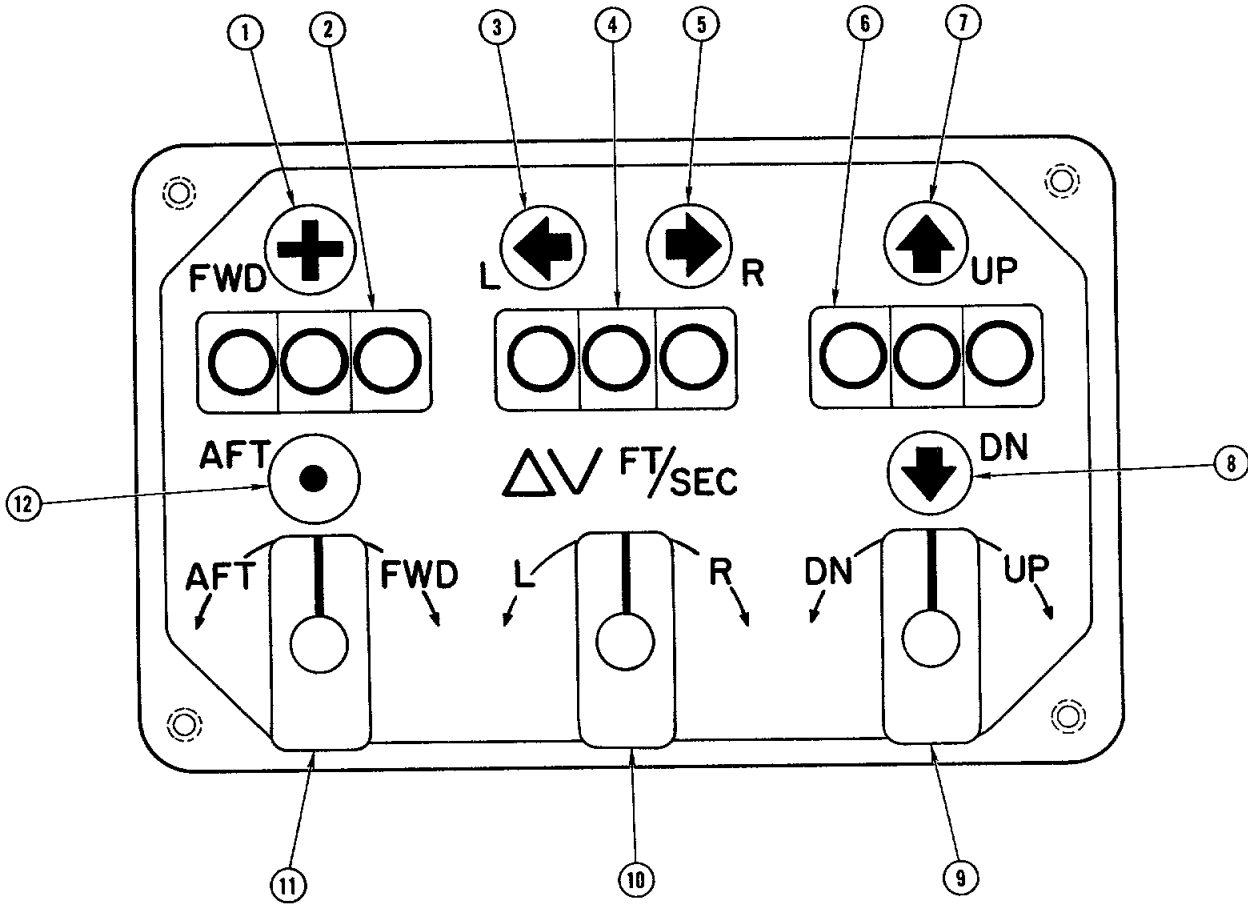
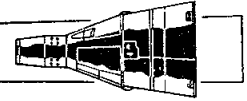

LEGEND		
ITEM	NOMENCLATURE	PURPOSE
①	FWD (FORWARD) DIRECTION INDICATION LAMP	INDICATES THAT PLUS X AXIS VELOCITY IS INSUFFICIENT.
②	FORWARD-AFT DISPLAY DEVICE	INDICATES AMOUNT OF INSUFFICIENT VELOCITY FOR PLUS OR MINUS X AXIS.
③	L (LEFT) DIRECTION INDICATION LAMP	INDICATES THAT MINUS Y AXIS VELOCITY IS INSUFFICIENT.
④	LEFT-RIGHT DISPLAY DEVICE	INDICATES AMOUNT OF INSUFFICIENT VELOCITY FOR PLUS OR MINUS Y AXIS.
⑤	R (RIGHT) DIRECTION INDICATION LAMP	INDICATES THAT PLUS Y AXIS VELOCITY IS INSUFFICIENT.
⑥	UP-DOWN DISPLAY DEVICE	INDICATES AMOUNT OF INSUFFICIENT VELOCITY FOR PLUS OR MINUS Z AXIS.
⑦	UP DIRECTION INDICATION LAMP	INDICATES THAT MINUS Z AXIS VELOCITY IS INSUFFICIENT.
⑧	DN (DOWN) DIRECTION INDICATION LAMP	INDICATES THAT PLUS Z AXIS VELOCITY IS INSUFFICIENT.
⑨	DN-UP ROTARY SWITCH	PROVIDES MEANS FOR MANUALLY SETTING UP Z AXIS VELOCITY ERROR ON UP-DOWN DISPLAY DEVICE.
⑩	L-R ROTARY SWITCH	PROVIDES MEANS FOR MANUALLY SETTING UP Y AXIS VELOCITY ERROR ON LEFT-RIGHT DISPLAY DEVICE.
⑪	AFT-FWD ROTARY SWITCH	PROVIDES MEANS FOR MANUALLY SETTING UP X AXIS VELOCITY ERROR ON FORWARD-AFT DISPLAY DEVICE.
⑫	AFT DIRECTION INDICATION LAMP	INDICATES THAT MINUS X AXIS VELOCITY IS INSUFFICIENT.

Figure 8-52 Incremental Velocity Indicator Front Panel



# PROJECT GEMINI



processes only the pulses received from the computer. However, rotation of the switches in either direction removes the pulses received from the computer and replaces them with pulses generated by an internal variable oscillator. These pulses are generated at a rate of one pulse per second for every 13.5 degrees of rotation until the rate reaches 10 pulses per second. Rotation of the switches beyond the 10 pulse per second position removes the pulses generated by the variable oscillator and replaces them with pulses generated by an internal fixed oscillator. These pulses are generated at a rate of 50 pulses per second. Rotation of the switches beyond the 50 pulses per second position is limited by mechanical stops.

The first pulse received on any channel, from either the computer or one of the oscillators, causes the appropriate display device to display a count of one. Simultaneously, this same pulse causes one of the two associated direction indication lamps to light. If the pulse was received on a positive input line, a forward, right, or down direction is indicated, depending on which channel (X, Y, or Z) received the pulse; and if the pulse was received on a negative input line, an aft, left, or up direction is indicated, depending on which channel received the pulse. Each additional pulse either increases or decreases the count depending on the relationship between the sign of the existing value on the counters and the sign of the added pulse as determined by the line on which it is received. A pulse having the same sign as the existing error increases the count; conversely, a pulse having the opposite sign of the existing error decreases the count. A series of pulses having the opposite sign indicates a corrective thrusting and eventually reduces the indicated error to zero. An overcorrection, causing still more pulses, causes the count to increase again but with the opposite direction indication lamp lit.

PROJECT GEMINI

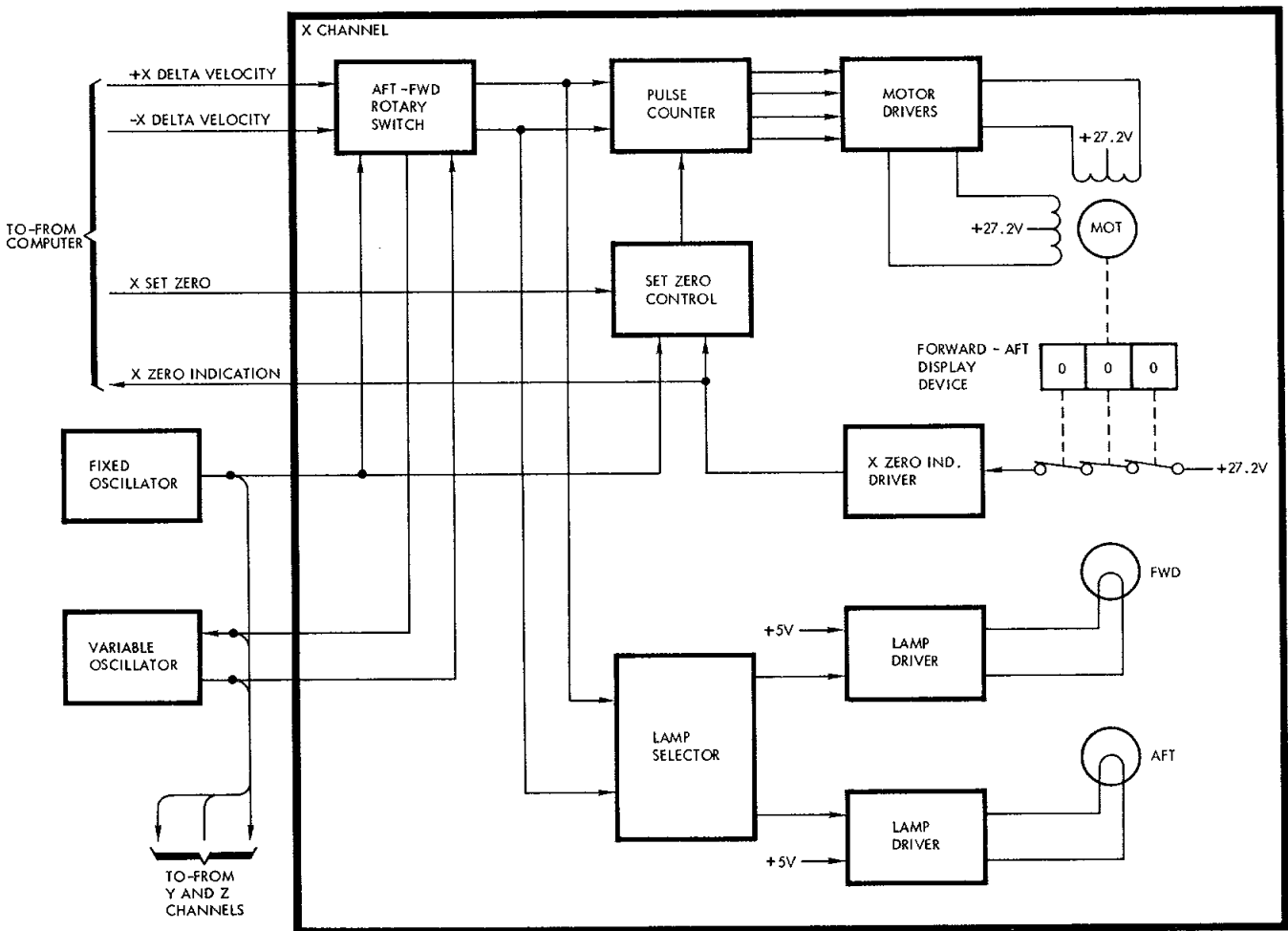
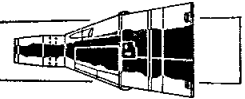

**NOTE**

Y AND Z CHANNELS ARE SAME AS X CHANNEL, EXCEPT Y CHANNEL CONTROLS AND INDICATORS ARE LEFT-RIGHT AND Z CHANNEL CONTROLS AND INDICATORS ARE UP-DOWN.

Figure 8-53 Incremental Velocity Indicator Data Flow



# PROJECT GEMINI



## Zero Indication

As shown on Figure 8-53, three series-connected switches are operated by the forward-aft display device. (The same thing is true for the Y and Z channels; however, since the three channels are identical, only the X channel is shown.) When the display device indicates 000, all three switches are closed. A +27.2 vdc signal is then applied to the X zero indication driver which develops the X zero indication signal that is supplied to the computer. This signal indicates that the respective counter is at zero.

## Pulse Count

Velocity error pulses are applied to the lamp selector and the pulse counter via the AFT-FWD rotary switch. If the switch is in the center position, these pulses are received from the computer on the +X delta velocity line and the -X delta velocity line. If the switch is not in the center position, the pulses are received from either the fixed oscillator or the variable oscillator. As previously explained, the oscillator that is used depends on the exact position of the switch. Regardless of the source of the pulses, the lamp selector and the pulse counter operate the same. The lamp selector determines, by means of the sign of the error, which lamp should be lit. Power is then supplied to the selected lamp via the associated lamp driver. Meanwhile, the same pulses are being processed by the pulse counter and supplied to the motor drivers. The pulse counter and the motor drivers operate in a manner that causes the motor to be driven 90 degrees for each pulse that is counted. The direction in which the motor is driven is determined by the relationship between the sign of the existing velocity error count and the sign of the added velocity error pulse. The motor drives the display device so that it changes by a count of one



# PROJECT GEMINI



for each 90 degrees of motor rotation. Thus the display device maintains an up-to-date count of the size of the velocity error for the associated axis (in this case, the X axis), and the direction indication lamps maintain an up-to-date indication of the direction of the error.

## Zero Command

The IVI counters can be individually driven to zero by means of set zero signals (X set zero, on Figure 8-53) supplied by the discrete output logic of the computer. The set zero signal is supplied to the set zero control circuit which gates the 50 pps output from the fixed oscillator into the pulse counter, provided the display device counter is not already at zero. The pulses from the fixed oscillator then drive the motor in the normal manner until the counter is zeroed. The pulses are applied in such a manner that the count always decreases, regardless of the initial value.

## Interfaces

The IVI interfaces, which are made with the computer and the IGS Power Supply, are described under the Interfaces heading in the DIGITAL COMPUTER SYSTEM OPERATION part of this section.

# HORIZON SENSOR SYSTEM

## TABLE OF CONTENTS

TITLE	PAGE
SYSTEM DESCRIPTION. . . . .	8-203
SENSOR HEAD. . . . .	8-203
ELECTRONICS PACKAGE. . . . .	8-205
SYSTEM OPERATION. . . . .	8-205
INFRARED OPTICS. . . . .	8-207
INFRARED DETECTION . . . . .	8-211
SERVO LOOPS. . . . .	8-212
HORIZON SENSOR POWER . . . . .	8-228
SYSTEM UNITS. . . . .	8-229
SENSOR HEAD. . . . .	8-229
ELECTRONICS PACKAGE. . . . .	8-232

# PROJECT GEMINI



DETAIL A

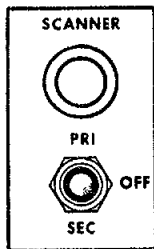

DETAIL B

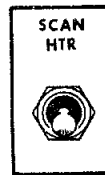

DETAIL C

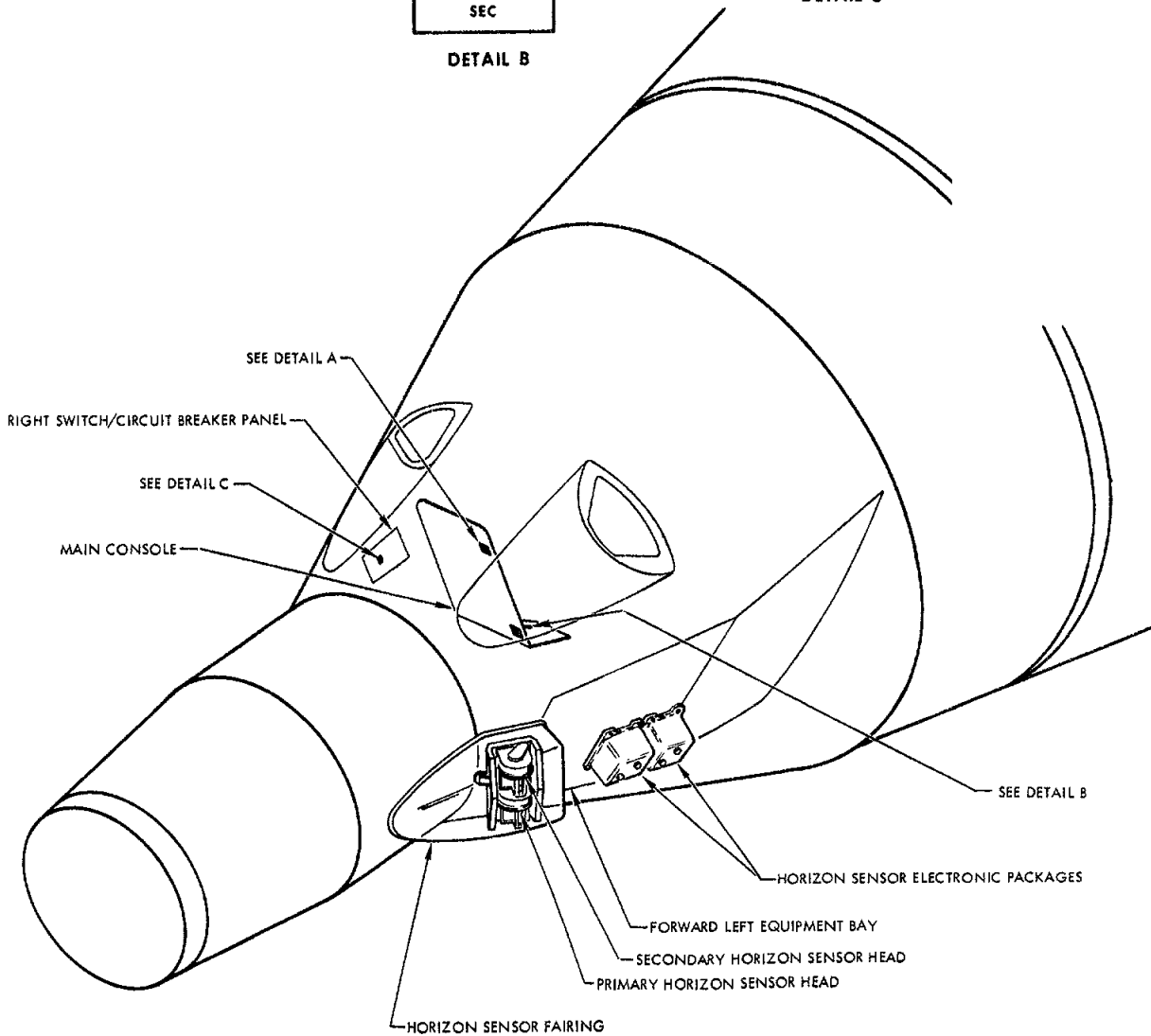
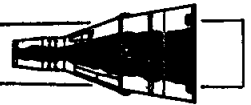

Figure 8-54 Horizon Sensor System



# PROJECT GEMINI



## HORIZON SENSOR SYSTEM

### SYSTEM DESCRIPTION

The Horizon Sensor System (Figure 8-54) consists of a sensor head, an electronics package and their associated controls and indicators. The system is used to establish a spacecraft attitude reference to earth local vertical and generates error signals proportional to the difference between spacecraft attitude and a horizontal attitude. Attitude error signals can be used to align either the spacecraft or the inertial platform to earth local vertical. The system has a null accuracy of 0.1 degree and is capable of operating at altitudes of 50 to 900 nautical miles. When the system is operating in the 50 to 550 nautical mile altitude range, measurable spacecraft attitude error is  $\pm 14$  degrees. When spacecraft attitude errors are between 14 and 20 degrees, the sensor output becomes non-linear but the direction of its slope always corresponds with the slope of the attitude error. When spacecraft attitude errors exceed 20 degrees, the system may lose track. Two complete systems are installed on the spacecraft. The second system is provided as a backup in case of primary system malfunction.

### SENSOR HEAD

The sensor head (Figure 8-55) contains equipment required to scan, detect and track the infrared gradient between earth and space, at the horizon. The sensor heads are mounted on the left side of the spacecraft and canted 14 degrees forward of the spacecraft pitch axis. Scanning is provided about the azimuth axis by a yoke assembly and about the elevation axis by a Positor (mirror positioning assembly). Infrared detection is provided by a bolometer and tracking by a servo loop which positions the Positor mirror.

PROJECT GEMINI

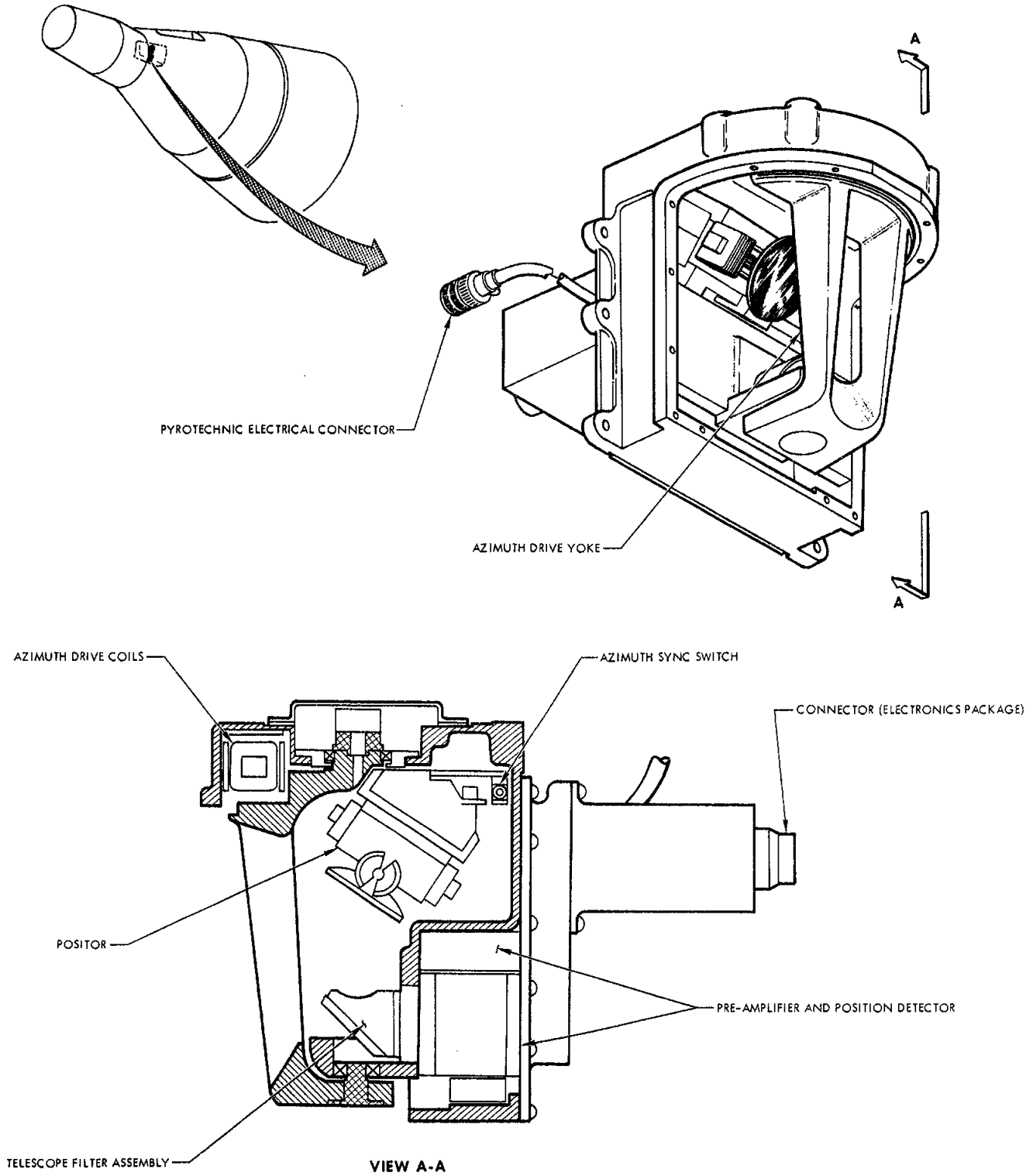

Figure 8-55 Horizon Sensor Scanner Head



# PROJECT GEMINI



## ELECTRONICS PACKAGE

The electronics package (Figure 8-56) contains the circuitry required to provide azimuth and elevation drive signals to the sensor head and attitude error signals to spacecraft and platform control systems. Electrical signals from the sensor head, representing infrared radiation levels and optical direction, are used to generate elevation drive signals for the Positor. Signals are also generated to constantly drive the azimuth yoke from limit to limit. Attitude error signals are derived from the constantly changing Positor position signal when the system is tracking.

## SYSTEM OPERATION

The primary Horizon Sensor System is energized during pre-launch by pilot initiation of the SCAN HTR and SCANNER PRI-OFF-SEC switches. Immediately after staging the pilot presses the JETT FAIR switch, exposing the sensor heads to infrared radiation. Initial acquisition time (the time required for the sensor to acquire and lock-on the horizon) is approximately 120 seconds; reacquisition time is approximately 10 seconds. The system can be used any time between staging and retrograde section separation. At retrograde section separation plus 80 milliseconds the sensor heads are automatically jettisoned, rendering the system inoperative.

Operation of the Horizon Sensor System depends on receiving, detecting and tracking the infrared radiation gradient between earth and space, at the horizon. To accomplish the above, the system employs infrared optics, infrared detection and three closely related servo loops. A functional block diagram of the Horizon Sensor System is provided in Figure 8-57.

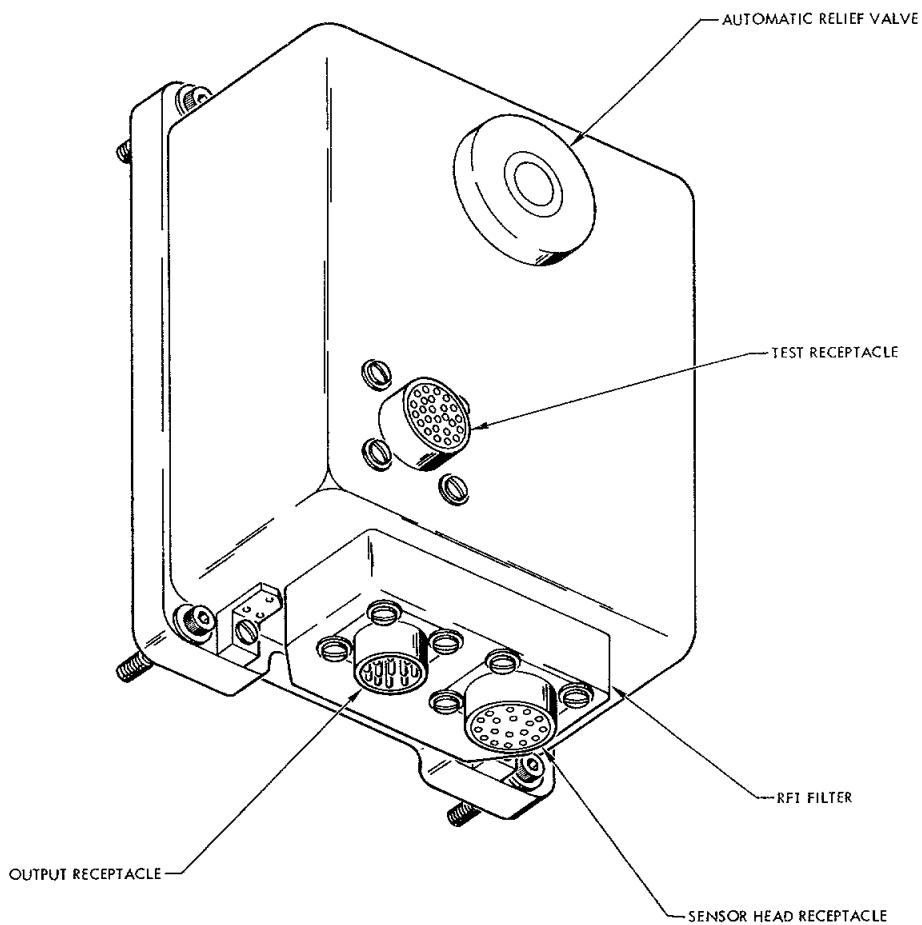
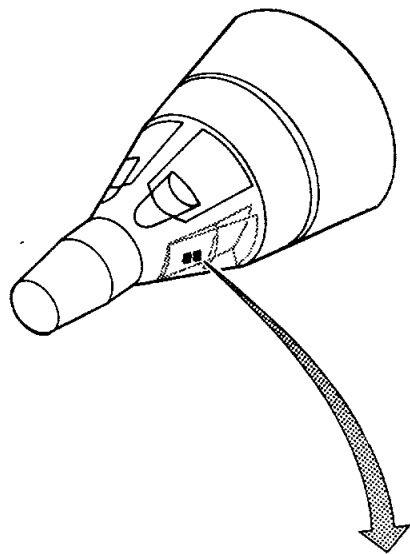
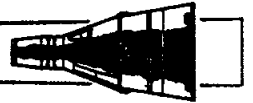

Figure 8-56 Horizon Sensor Electronic Package



# PROJECT GEMINI



## INFRARED OPTICS

Infrared optics (Figure 8-58) consists of a Positor, a telescope-filter assembly and an azimuth drive yoke. All of these components are located in the sensor head. The Positor has a movable mirror which is used to position the system field of view about the horizon. Radiation is reflected by the Positor mirror into the telescope-filter assembly. A fixed mirror, in the telescope-filter assembly, directs infrared radiation into the telescope. The telescope-filter assembly contains a germanium meniscus objective lens, an infrared filter and a germanium-immersed thermistor bolometer. The objective lens is used to direct all the infrared radiation, reflected by the mirrors, on the germanium immersion lens of the bolometer. The infrared filter is used to eliminate radiation of undesired frequencies. The filter has a band pass of 8 to 22 microns (80,000 to 220,000 angstroms). The germanium immersion lens focuses the infrared radiation on an immersed thermistor.

The horizon sensor field of view is deflected through 160 degrees ( $\pm 80$ ) in azimuth and 70 degrees (12 up and 58 down) in elevation by rotating the Positor mirror. The Positor is rotated in azimuth by a drive yoke. Rotation is about an axis which runs through the center of the infrared ray bundle on the surface of the Positor mirror. The yoke is driven at a one cycle per second rate by circuitry in the electronics package. The center of the azimuth scan is 14 degrees forward of the spacecraft pitch axis. This is due to the mounting of the scanner heads. Elevation deflection is provided by the Positor which tilts the Positor mirror as required to search for or track the horizon. The

# PROJECT GEMINI

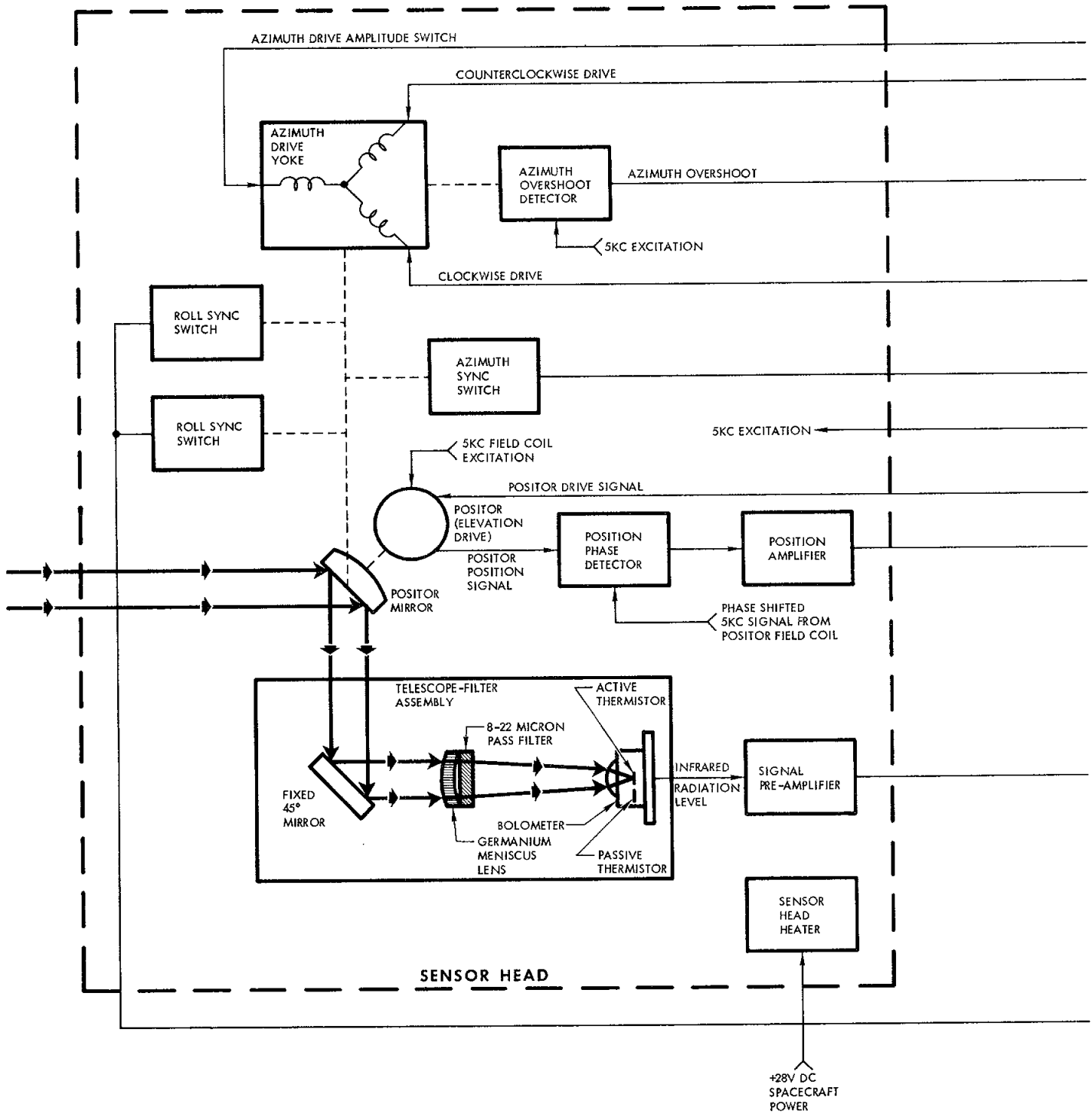
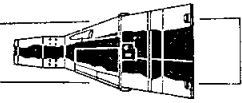

Figure 8-57 Horizon Sensor System Functional Block Diagram (Sheet 1 of 2)

# PROJECT GEMINI

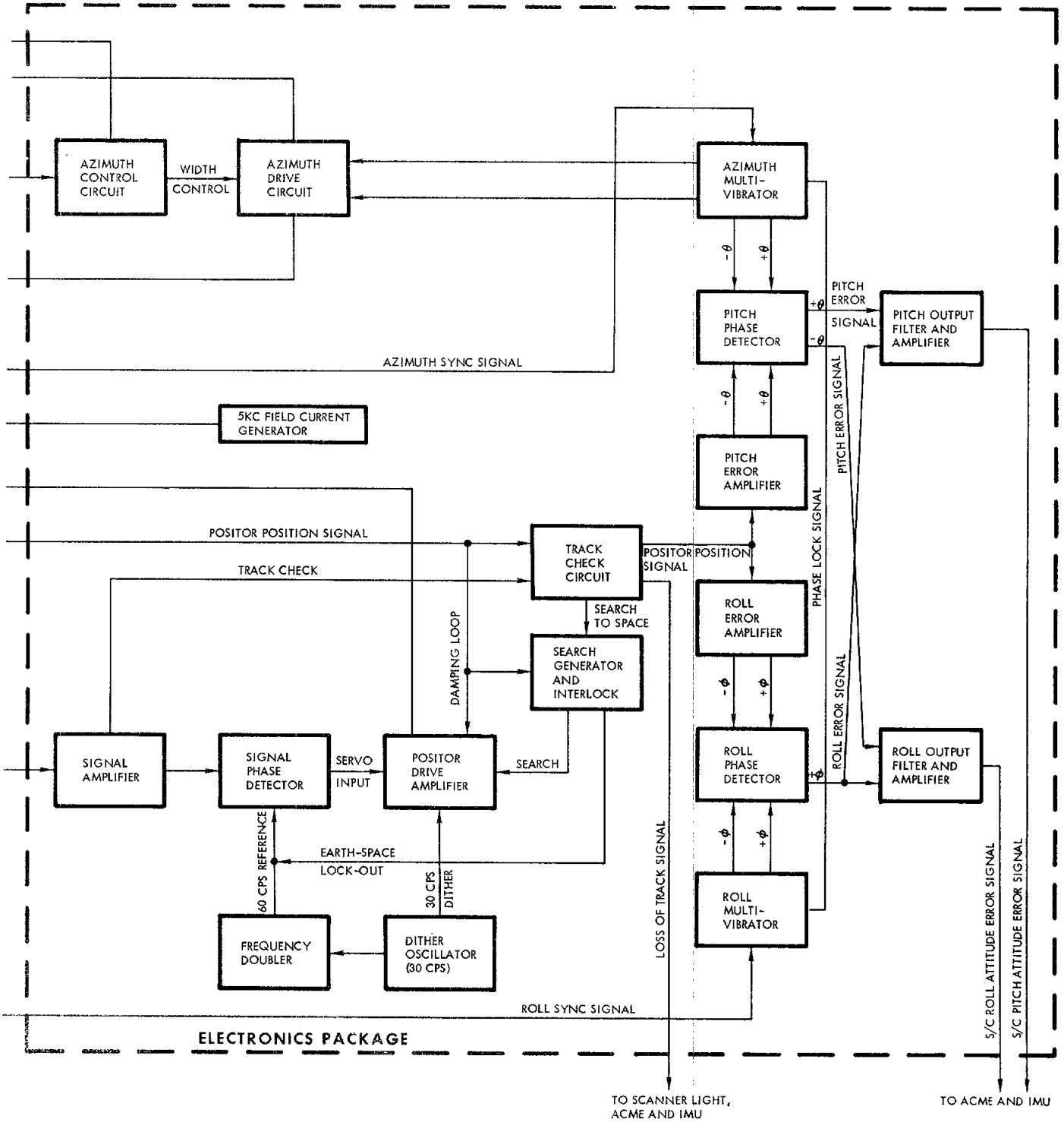
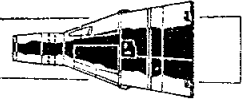

Figure 8-57 Horizon Sensor System Functional Block Diagram (Sheet 2 of 2)

# PROJECT GEMINI

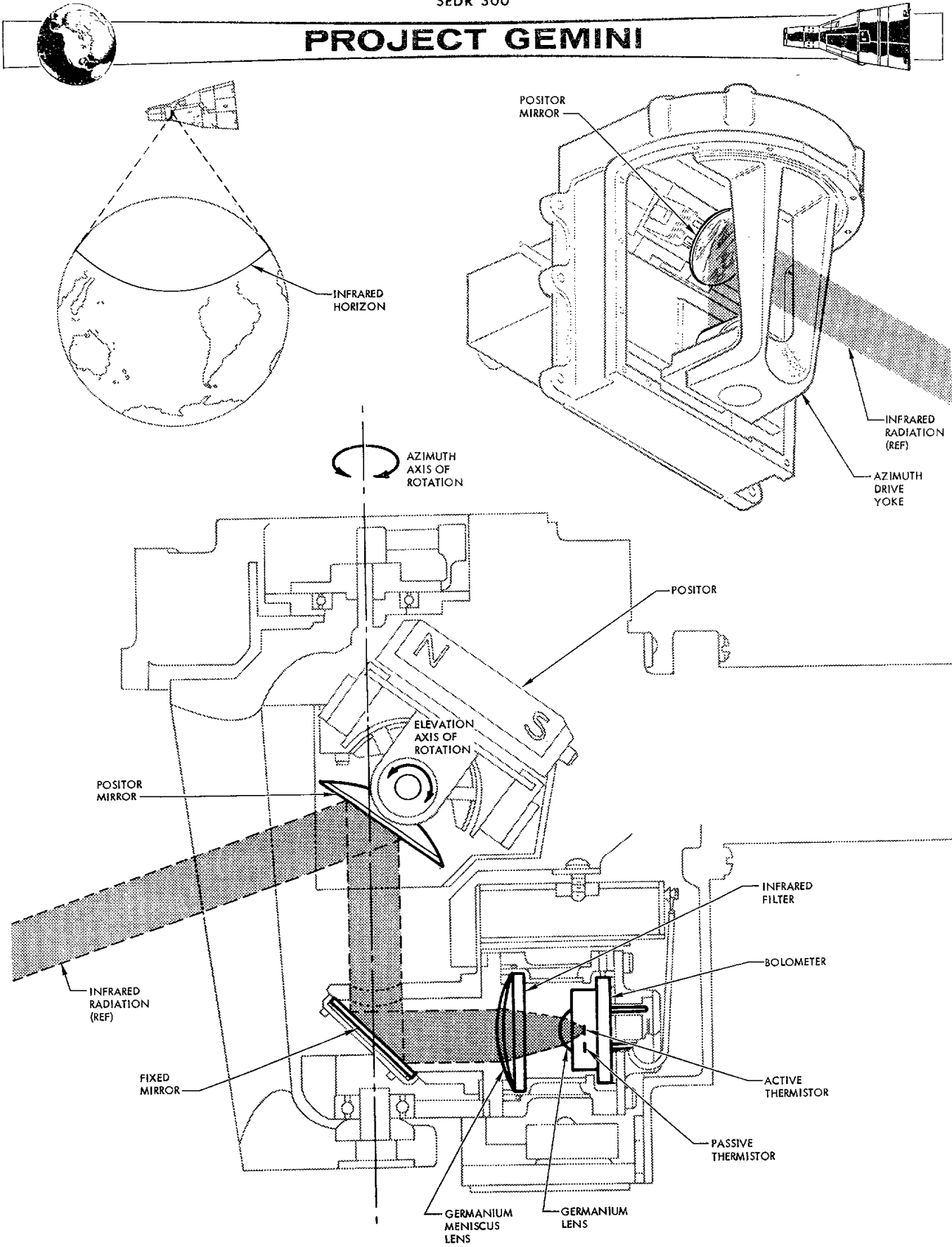

Figure 8-58 Infrared Optics



## PROJECT GEMINI



rate at which the Positor tilts the mirror is a function of the mode of operation (track or search). In search mode, the Positor mirror moves at a two cps search rate plus a 30 cps dither rate. In track mode, the Positor mirror moves at a 30 cps dither rate, plus, if there is any attitude error, a one or two cps track rate. The one or two cps track rate depends on the direction of spacecraft attitude error.

### INFRARED DETECTION

Infrared radiation is detected by the germanium-immersed thermistor bolometer. The bolometer contains two thermistors (temperature sensitive resistors) which are part of a bridge circuit. One of the thermistors (active) is exposed to infrared radiation from the horizon. The second thermistor (passive) is located very near the first thermistor but it is separated from infrared radiation. Radiation from the horizon is sensed by the active thermistor which changes resistance and unbalances the bridge circuit. The unbalanced bridge produces an output voltage which is proportional to the intensity of the infrared radiation. If only one thermistor were used, the bridge would also sense temperature changes caused by conduction or convection; to prevent this, a passive (temperature reference) thermistor is used.

The passive thermistor changes resistance the same amount as the active thermistor, for a given ambient temperature change, keeping the bridge balanced. The passive thermistor is not exposed to infrared radiation and allows the bridge to become unbalanced when the active thermistor is struck by radiation from the horizon.



# PROJECT GEMINI



## SERVO LOOPS

The three servo loops used by the Horizon Sensor System are: the track loop, the azimuth drive loop and the signal processing loop. Some of the circuitry is used by more than one servo loop and provides synchronization.

### Track Loop

The track loop (Figure 8-59) is used to locate and track the earth horizon with respect to the elevation axis. Two modes of operation (search and track) are used in the track loop. The search mode is selected automatically when the system is first energized and used until the horizon is located. After the horizon is located and the signal built up to the required level, the track mode is automatically selected.

### Search Mode

The search mode is automatically selected by the system any time the horizon is not in the field of view. The purpose of the search mode is to move the system line of sight through its elevation scan range until the horizon is located. (The system line of sight is moved by changing the angle of the positor mirror.) When the system is initially energized, the Positor position signal is used to turn on a search generator. The generator produces a two cps ac search voltage which is applied to a summing junction in the Positor drive amplifier. A second signal (30 cps dither) is also applied to the summing junction. (The dither signal is present any time the system is energized.) The search and dither voltages are summed and amplified to create a Positor drive signal. This drive signal is applied to the drive coils of the Positor causing it to tilt the Positor mirror. The dither portion of the signal causes the mirror to oscillate about its elevation axis at a 30 cps rate and

# PROJECT GEMINI

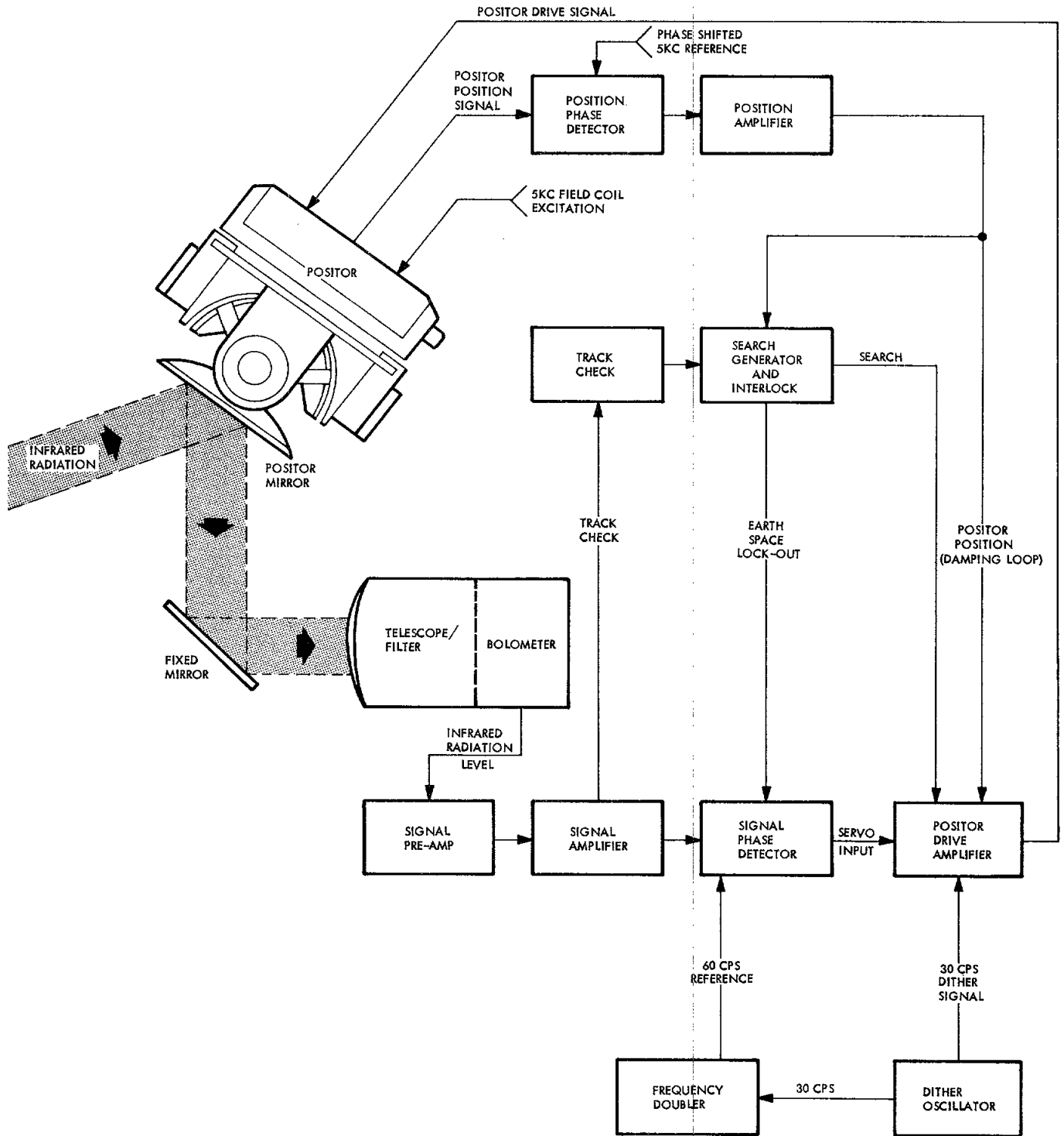
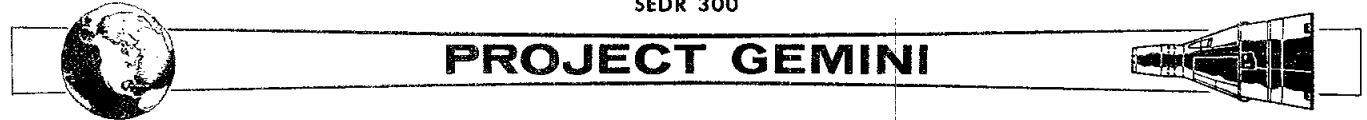
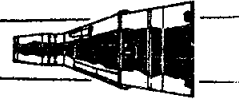

Figure 8-59 Track Loop Block Diagram



## PROJECT GEMINI



through an angle which represents approximately four degrees change in the line of sight. The search portion of the signal will drive the Positor mirror up to an angle which represents a line of sight 12 degrees above the spacecraft azimuth plane. During the up scan (earth to space) a lock-out signal is applied to the servo loop to prevent the system from locking on to false horizon indications. When the positive limit of the search voltage (12 degrees up) is reached, the voltage changes phase and the system begins to scan from 12 degrees up to 58 degrees down. During the down scan (space to earth), the lock-out signal is not used and the system is free to select track mode if the horizon comes within the field of view.

The bolometer output (indication of infrared radiation) is used to determine when the horizon comes within view and to initiate the track mode of operation. As the system line of sight crosses the horizon (from space to earth), a sharp increase in infrared radiation is detected by the bolometer. The bolometer bridge output now produces a 30 cps ac signal. (The 30 cps is caused by the dither signal driving the line of sight back and forth across the horizon.) The bolometer bridge output is amplified and applied to the track check circuit. When the 30 cps signal reaches the track check circuit, it causes a tracking relay to be energized indicating that the horizon is in the field of view. Contacts of the relay apply a bias to the search generator, turning it off and removing the search voltage from the Positor drive signal. This places the system in the track mode of operation.



# PROJECT GEMINI



## Track Mode

The bolometer output signal is used to determine the direction of the horizon from the center of the system line of sight. A Positor drive voltage of the proper phase is then generated to move the system line of sight until the horizon is centered in the field of view. The bolometer output signal is phase detected with respect to a 60 cps reference signal. The 60 cps signal is obtained by doubling the frequency output of the dither oscillator. Since both signals (30 cps dither and 60 cps reference) come from the same source, the phase relationship should be a constant. However, when the horizon is not in the center of the field of view, the bolometer output is not symmetrical. The time required for one complete cycle is the same as for dither but the zero crossover is not equally spaced, in time, from the beginning and end of each cycle. The direction the zero crossover is shifted from center depends on whether the horizon is above or below the center of the field of view. The phase detector determines the direction of shift (if any) and produces dc pulses of the appropriate polarity. The output of the signal phase detector is applied to the Positor drive amplifier where it is summed with the dither signal. The composite signal is then amplified and used to drive the Positor mirror in the direction required to place the horizon in the center of the field of view.

A pickup coil, wound on the permanent magnet portion of the Positor drive mechanism, produces an output signal which is proportional (in phase and amplitude) to the position of the Positor mirror. This Positor position signal is phase detected to determine the actual position of the mirror. The detector output is then amplified and used for two purposes in the track loop: to activate



# PROJECT GEMINI

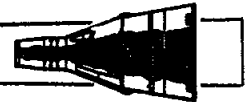

the search generator when the tracking relay is de-energized and as a rate damping feedback to the Positor drive amplifier. (When the tracking relay is energized, it biases the search generator to cutoff.)

## Azimuth Drive Loop

The azimuth drive loop (Figure 8-60) provides the drive voltage, overshoot control and synchronization required to move the system line of sight through a 160 degree scan angle at a one cps rate. The azimuth drive loop consists of an azimuth overshoot detector, azimuth control circuit, azimuth multivibrator, azimuth drive coils and an azimuth drive yoke.

## Azimuth Overshoot Detector

The azimuth overshoot detector does not, as the name implies, detect the azimuth scan overshoot. It instead detects when the azimuth drive yoke reaches either end of its scan limit. The detector is a magnetic pickup, located near the azimuth drive yoke and excited by a 5 kc signal from the field current generator. Two iron slugs, mounted on the azimuth drive yoke, pass very near the magnetic pickup when the yoke reaches the scan limit. The slugs are positioned 160 degrees apart on the yoke to represent each end of the scan. When one of the iron slugs passes near the magnetic pickup, it changes the inductance and causes the 5 kc excitation signal to be modulated with a pulse. Since the azimuth scan rate is one cps and the modulation occurs at each end of the scan, the overshoot pulse occurs at a two pps rate. Output of the overshoot detector is applied to the azimuth control circuit.

# PROJECT GEMINI

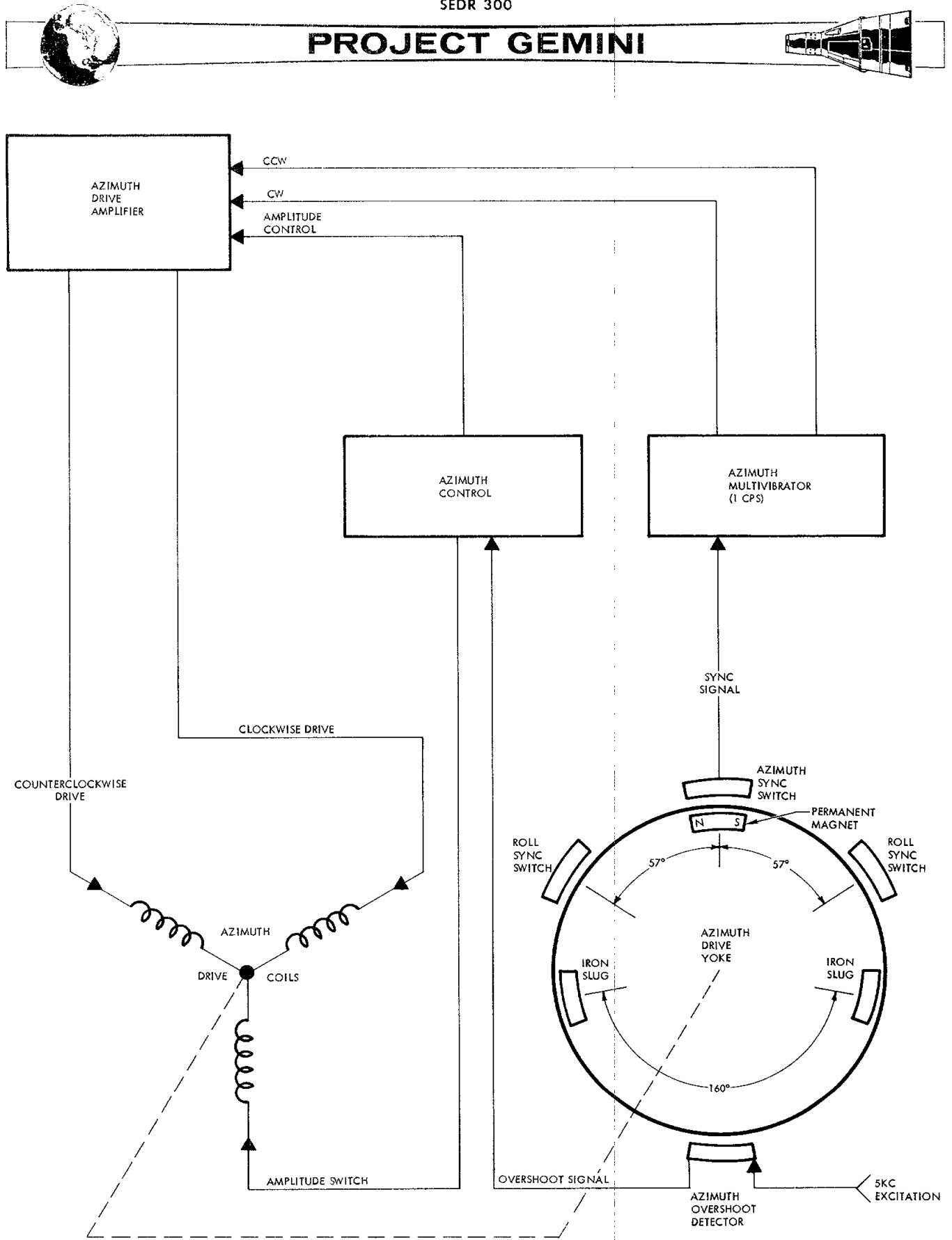
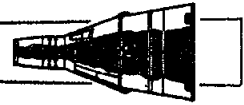

Figure 8-60 Azimuth Drive Loop Block Diagram



# PROJECT GEMINI



## Azimuth Control Circuit

The azimuth control circuit generates two types of azimuth control voltages (coarse and fine) based on the azimuth overshoot signal. The azimuth overshoot detector output is rectified, filtered, peak detected and integrated to develop a dc control voltage proportional to the amplitude and width of the overshoot pulse. This control voltage serves two purposes: to provide continuous, fine control of the azimuth drive pulse and, when the control voltage reaches a high enough level (indicating a large overshoot), provide a coarse (step) control of the reference voltage on the azimuth drive coils. The fine control is obtained by applying the control voltage, as a bias, to the azimuth drive amplifier. The coarse control is obtained by energizing a relay, which switches the reference voltage on the azimuth drive coils when the control voltage reaches a high enough level. The level at which the relay energizes is determined by a zener diode which breaks down and biases a relay driver into conduction. The relay driver then energizes a relay which switches the dc voltage on the reference winding of the azimuth drive coils.

## Azimuth Multivibrator

The azimuth multivibrator provides the direction control signal for the azimuth drive. The multivibrator is synchronized by pulses from the azimuth sync switch. The sync switch is located next to the azimuth drive yoke and is closed each time the yoke passes through the center of its 160 degree scan. The switch produces a two pps output which is used to switch the state of the multivibrator. The multivibrator then produces a one cps square wave signal which is



# PROJECT GEMINI



synchronized with the motion of the azimuth drive yoke. The positive half of the square wave controls the azimuth drive in one direction and the negative half controls the drive in the other direction. Output of the multivibrator is applied to the azimuth drive amplifier.

## Azimuth Drive Amplifier

The azimuth drive amplifier adjusts the width of multivibrator output pulses to control the azimuth drive yoke. The output pulse width, from the drive amplifier, depends on the amount of control voltage (bias) provided by the azimuth control circuit. When the amount of azimuth yoke overshoot is large, the control voltage is high and the output pulse width is narrow. As the amount of overshoot decreases, the control bias decreases and the output pulse width increases. This provides a continuous, fine control over the drive pulse and consequently the amount of azimuth drive yoke travel.

## Azimuth Drive Coils

The azimuth drive coils convert drive signals into a magnetic force. The coils are mounted next to, and their magnetic force exerted on, the azimuth drive yoke. The direction of magnetic force is determined by which drive coil is energized.

## Azimuth Drive Yoke

The azimuth drive yoke is a means of mechanically moving the system line of sight through a scan angle. (The Positor is mounted inside the azimuth drive yoke and the rotation is around the center line of the infrared ray bundle on the Positor mirror.) The azimuth drive yoke is spring loaded to its center position and the mass adjusted to give it a natural frequency of one cps. Mounted on the yoke



## PROJECT GEMINI

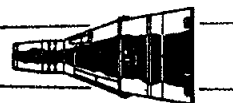

are two iron slugs and a permanent magnet. The iron slugs are used in conjunction with the azimuth overshoot detector mentioned previously. The magnet is used to activate sync switches located next to the drive yoke. The switches synchronize mechanical motion of the yoke with electrical signals. The function of the azimuth sync switch was described in the azimuth multivibrator paragraph. The function of the two roll sync switches will be described in the phase detectors paragraph of the signal processing loop.

### Signal Processing Loop

The signal processing loop (Figure 8-61) converts tracking and azimuth scan information into attitude error signals. (The error signals can be used to align the spacecraft and/or the Inertial Guidance System to the earth local vertical.) A complete servo loop is obtained by utilizing two other spacecraft systems (Attitude Control and Maneuver Electronics and the Propulsion System). Attitude error signals, generated by the Horizon Sensor System are used by the Attitude Control and Maneuver Electronics (ACME) (in the horizon scan mode) to select the appropriate thruster (or thrusters) and generate a fire command. The fire command causes the Propulsion System to produce thrust in the desired direction. As the thrust changes spacecraft attitude, in the appropriate direction, the attitude error signals decrease in amplitude. When the spacecraft attitude comes within preselected limits (0 to -10 degrees in pitch and  $\pm 5$  degrees in roll), as indicated by error signal amplitude, the ACME stops generating fire commands. As long as the spacecraft attitude remains within the preselected limits, it is allowed to drift freely. If the attitude exceeds the limits, thrust is automatically applied to correct the error.

# PROJECT GEMINI

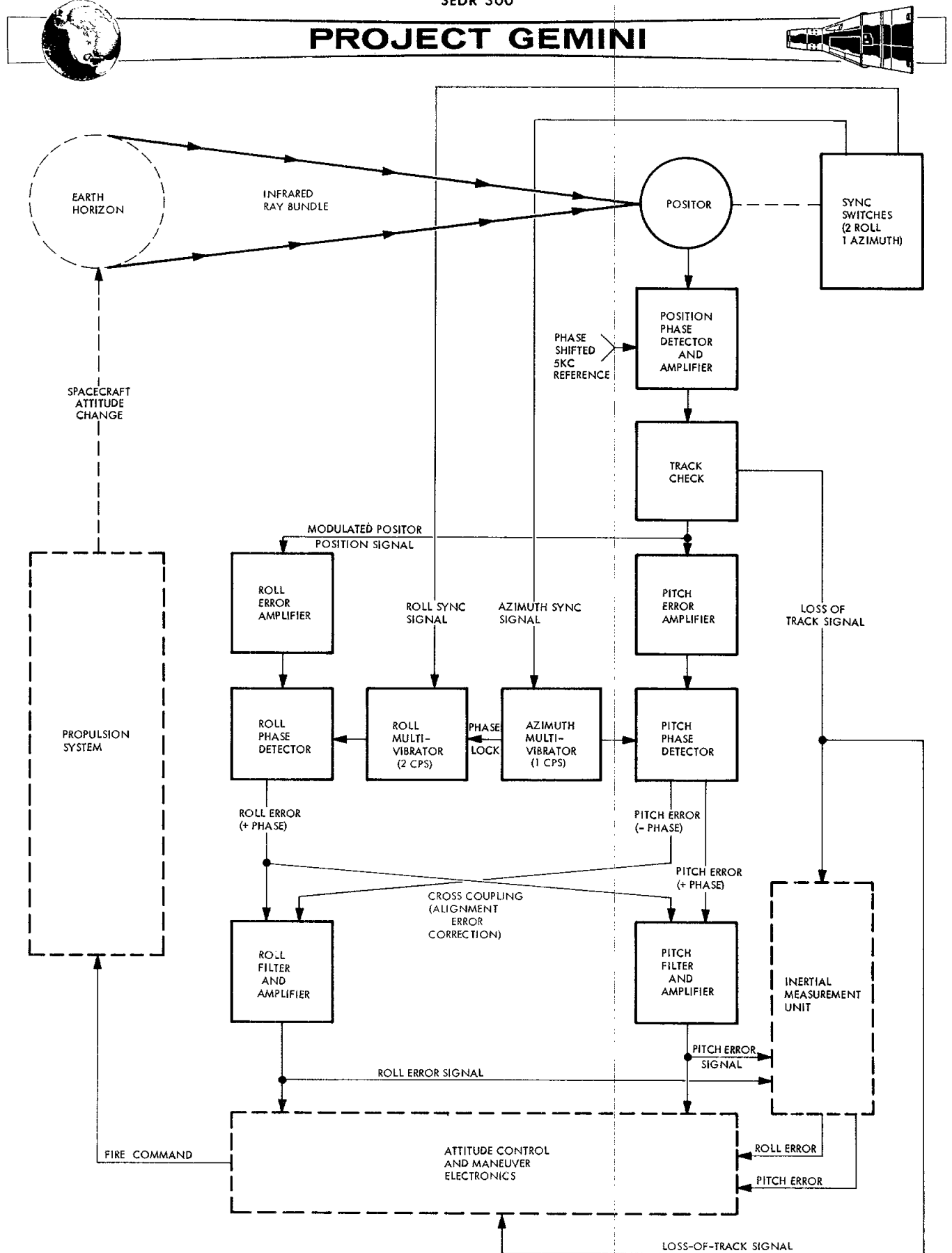

Figure 8-61 Signal Processing Loop Block Diagram



# PROJECT GEMINI



An indirect method of controlling spacecraft attitude (on spacecraft 5, 6 and 8 through 12) with the horizon sensor involves a third spacecraft system (Inertial Guidance). This method can be used when it is desired to fine align the inertial measurement unit. Horizon sensor attitude error signals are now used to continuously torque gyros in the inertial platform, aligning them to the local vertical. The platform attitude error signals are then used by the ACME (in the platform mode) to generate fire commands for the Propulsion System. Using this method of attitude control, the spacecraft is held to within  $\pm 1.1$  degrees of the platform attitude in all three axes.

The inertial platform can also be aligned by the horizon sensor without using a servo loop. To align the platform without a closed servo loop, the pilot must manually maintain spacecraft attitude as near null as possible. (The horizon sensor attitude error signals are most accurate when the spacecraft is in a horizontal attitude with respect to the earth surface.) Attitude error signals are then used to torque platform gyros and have no direct effect on spacecraft attitude.

The Horizon Sensor System also provides a loss of track indication to both the ACME and Inertial Guidance System. The signal is used to prevent the ACME or platform from aligning to a false horizon. The loss of track signal is also used to illuminate the SCANNER light on the pedestal, informing the pilot that the system is not tracking. (Spacecraft attitude must be held within  $\pm 20$  degrees of the horizontal for the system to track.)

# PROJECT GEMINI

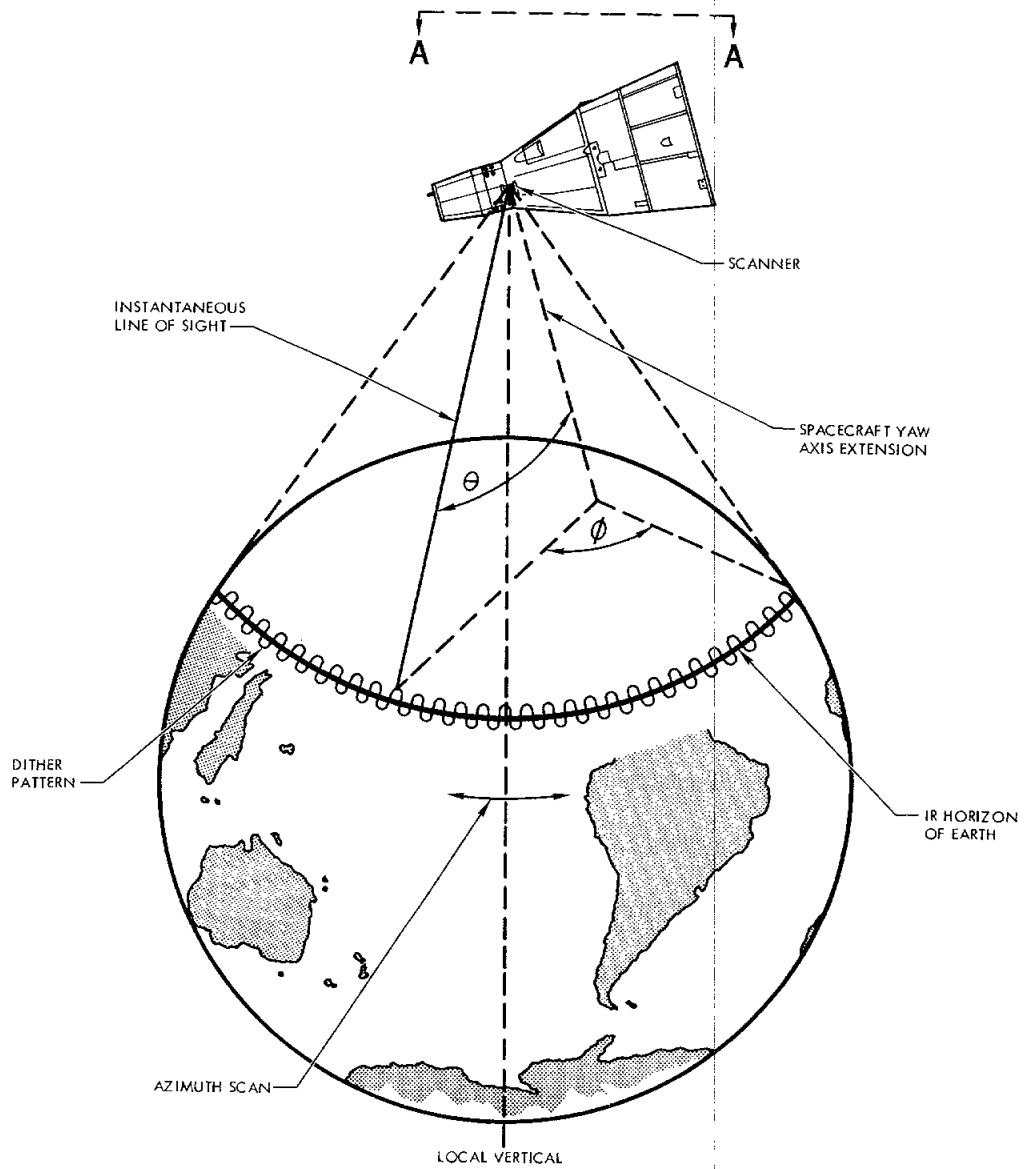
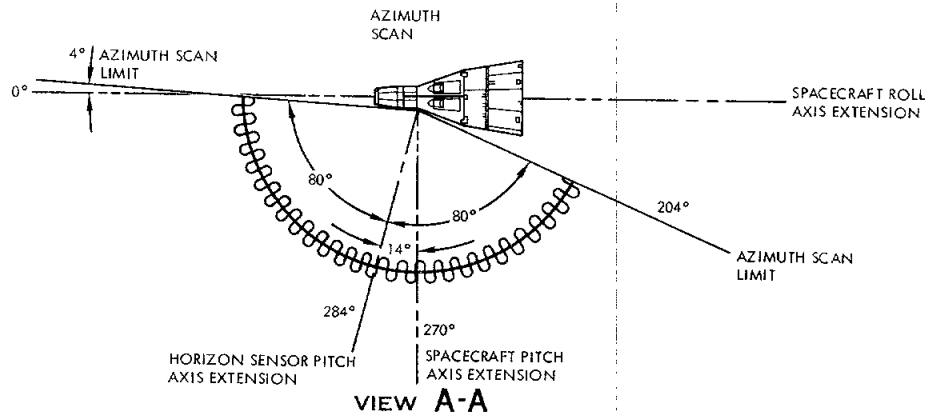

Figure 8-62 Horizon Sensor Tracking Geometry



# PROJECT GEMINI



## Tracking Geometry

Horizon sensor tracking geometry (Figure 8-62) is composed of the elevation angles ( $\theta$ ) generated by the track loop and the azimuth angles ( $\phi$ ) generated by the azimuth drive loop. Angles are compared in time and phase to generate an error signal proportional to the elevation angle change with respect to the azimuth scan angle.

As explained in the track loop paragraph, the system will lock on in elevation and track the earth horizon. A dither signal causes the Positor to move the system line of sight about the horizon at a 30 cps rate. The track loop will move the Positor mirror such that the horizon is always in the center of the dither pattern. It was also explained, in the azimuth drive loop paragraph, that the system line of sight is continuously moved through a 160 degree azimuth scan angle at a one cps rate.

When the spacecraft is in a horizontal attitude, the azimuth scan has no effect on the elevation angle of the Positor as it tracks the horizon. If the spacecraft is in a pitch up attitude, the elevation angle ( $\theta$ ) will decrease as the azimuth angle ( $\phi$ ) approaches 80 degrees forward and increase as angle  $\phi$  approaches 80 degrees aft. If the spacecraft is in a pitch down attitude, the elevation angle will increase as the azimuth angle approaches 80 degrees forward and decrease as the azimuth angle approaches 80 degrees aft. This produces a one cps pitch error signal which is superimposed on the 30 cps Positor dither.

If the spacecraft has a roll right attitude, the elevation angle will increase as the azimuth angle approaches either limit and decrease as the azimuth angle approaches zero from either limit. If the spacecraft is in a roll left attitude



# PROJECT GEMINI



the elevation angle will decrease as the azimuth angle approaches either limit and increase as the azimuth angle approaches zero from either limit. This produces a two cps error signal which is superimposed on the 30 cps Positor dither.

## Position Phase Detector

The Positor position phase detector compares the Positor pickoff signal with a 5 kc reference to determine the angle of the Positor mirror. (The mirror angle will be changing at a 30 cps dither rate, plus, if there is any spacecraft attitude error, a one and/or two cps error signal rate.) The phase detector output is then amplified and applied to the track check circuit.

## Track Check

The track check circuit determines when the horizon is in the field of view. If the horizon is in the field of view, the track check circuit energizes a relay. Contacts of this relay connect the Positor position signal to the pitch and roll error amplifiers. A second relay in the track check circuit, energized when the system is not tracking, provides a loss of track indication to the inertial measurement unit and the ACME. The loss of track signal is 28 volts dc obtained through the ATT IND CNTL-LDG circuit breaker and switched by the track check circuit.

## Error Amplifiers

In order to obtain individual pitch and roll attitude error outputs, error signal separation must be accomplished. This function is performed by two error amplifiers. The Positor position signal input to the error amplifiers is a composite 30 cps dither, one cps pitch error and two cps roll error signal. The pitch error amplifier is tuned to one cps and selects the pitch error signal only for



# PROJECT GEMINI

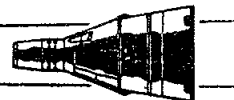

amplification. The roll error amplifier is tuned to two cps and selects the roll error signal only for amplification. Each amplifier then amplifies and inverts their respective signals, producing two outputs each. The outputs are 180 degrees out of phase and of the same frequency as their input circuits were tuned. Output of each error amplifier is coupled to its respective phase detector.

## Phase Detectors

Phase detectors compare the phase of pitch and roll error signals with one and two cps multivibrator reference signals to determine the direction of attitude error. The multivibrators are synchronized with motion of the azimuth drive yoke by three sync switches. Two sync switches, located at 57 degrees on either side of the center position of the yoke, synchronize the roll multivibrator with the motion of the yoke and set its frequency at two cps. The sync switches close each time the yoke passes, in either direction, producing four pulses for each cycle of the yoke. Each time a pulse is produced it changes the state of the multivibrator resulting in a two cps output. The azimuth multivibrator operates in the same manner except that it only has one sync switch, located at the center of the drive yoke scan, resulting in a one cps output frequency. The azimuth multivibrator also provides a phase lock signal to the roll multivibrator to assure not only frequency synchronization but correct phasing as well. The phase detectors themselves are actually reed relays, two for each detector, which are energized alternately by their respective multivibrator output signals. Contacts of these relays combine the two input signals in such a manner that two full wave rectified output signals are produced. The polarity of these pulsating dc outputs indicates the direction and the amplitude indicates the amount of attitude error about the horizon sensor pitch and roll axes. Since the sensor head was mounted at a 14 degree angle with

**PROJECT GEMINI**

400 CPS  
ACME POWER  
(FROM SCANNER  
SWITCH)

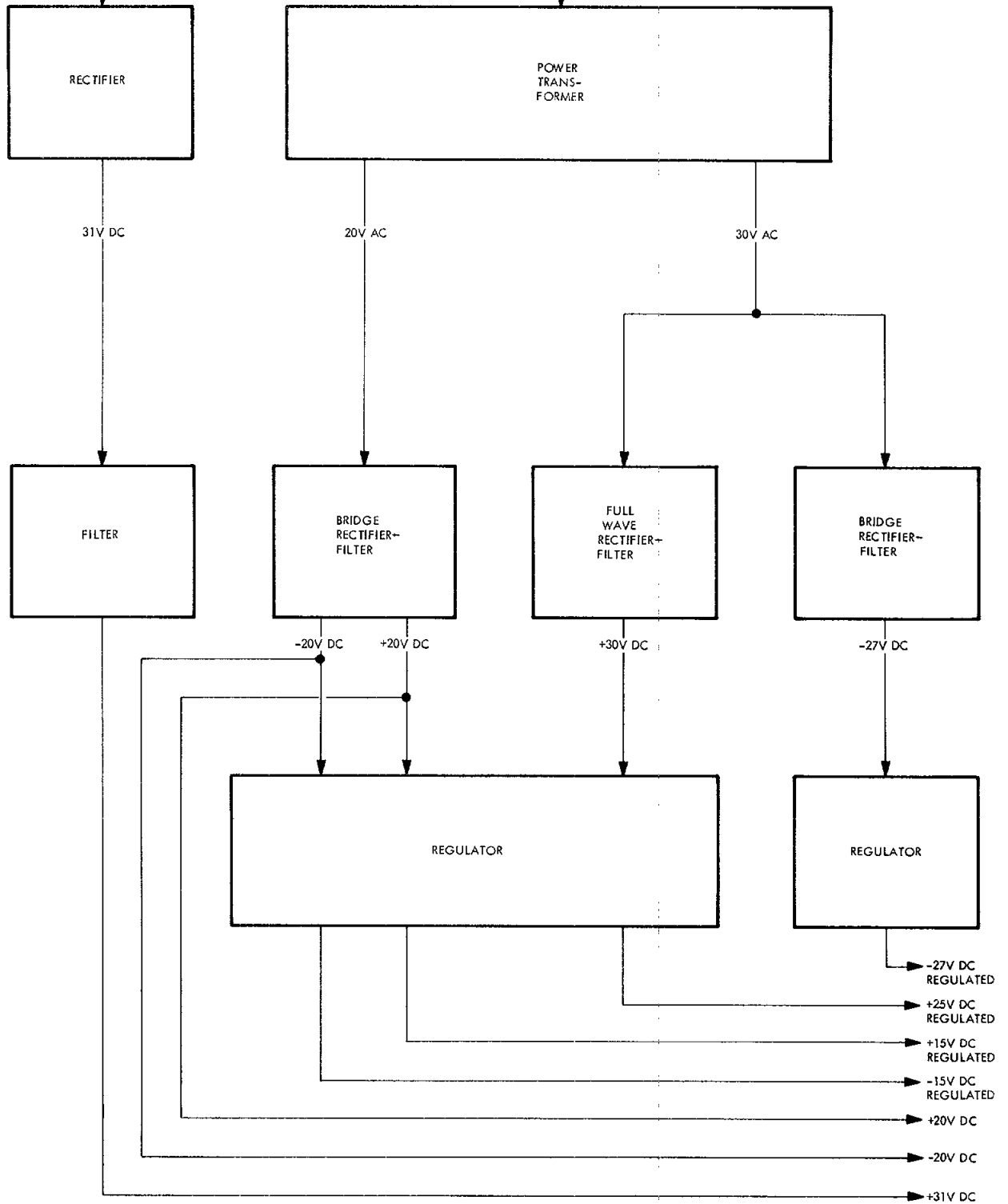

Figure 8-63 Horizon Sensor Power Supply Block Diagram



# PROJECT GEMINI



respect to the spacecraft, the mounting error must be compensated for. Electrical rotation of the horizon sensor axes, to correspond with spacecraft axes, is accomplished by cross coupling a portion of the pitch and roll error signals.

## Output Amplifier and Filter

The output amplifier-filter removes most of the two and four cps ripple from the rectified attitude error signals and amplifies the signals to the required level. The identical pitch and roll operational amplifiers, used as output stages for the Horizon Sensor System, are highly stable and have a low frequency response. The output signal amplitude is four tenths of a volt for each degree of spacecraft attitude error. The signals are supplied to the ACME for spacecraft alignment and to the inertial measurement unit for platform alignment.

## HORIZON SENSOR POWER

Horizon sensor power (Figure 8-63) is obtained from the 28 volt dc spacecraft bus and the 26 volt ac, 400 cps ACME power. The 28 volt dc power, supplied through the SCAN HTR switch, is used to maintain temperature in the sensor head and as power for the SCANNER lamp. Sensor head heaters are thermostatically controlled and operate any time the SCAN HTR switch is on. The 26 volt ac, 400 cps ACME power is provided by either the IGS or ACME inverter, depending on the position of the ac POWER selector. The 26 volt ac is used to produce seven different levels of dc voltage used in the horizon sensor. One of the voltages (31 volts dc) is obtained by rectifying and filtering the 26 volt ac input. The remaining six levels are obtained by transforming the 26 volts to the desired level, then rectifying, filtering and regulating it as required. The minus 27 volts dc output is used to excite one side of the bolometer bridge. The other side of the bridge is excited



# PROJECT GEMINI

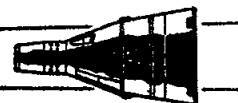

by plus 25 volts dc. Plus 25 volts dc is also used for transistor power in the error amplifiers. The 31 volt dc unregulated output is used as excitation for the azimuth drive yoke. The remaining four voltages (+15, -15, +20, -20) are all used for transistor power in the various electronic modules.

## SYSTEM UNITS

The Horizon Sensor System (Figure 8-54) consists of two major units and five minor units. The minor units are: three switches, an indicator light and a fiberglass fairing. The three switches are mounted on the control panels for pilot actuation. The indicator light is mounted on the pedestal and, when illuminated, indicates a loss of track. The fiberglass fairing is dust proof and designed to protect the sensor heads, which it covers, from accidental ground damage or thermal damage during launch. The two major units are: the sensor head and the electronics package.

## SENSOR HEAD

The sensor head (Figure 8-55) is constructed from a magnesium casting and contains a Positor, a telescope-filter assembly, a signal preamplifier, a position detector, an active filter and an azimuth drive yoke. The Positor (Figure 8-64) is a mirror positioning assembly designed to position a mirror about its elevation axis. The mirror is polished beryllium and is pivoted on ball bearings by a magnetic drive. The Positor also includes a position pickoff coil for determining the angle of the Positor mirror.

The telescope-filter assembly (see Figure 8-58) contains a fixed mirror, a germanium meniscus lens, an infrared filter and a germanium immersed thermistor bolometer. The fixed mirror is set at a 45 degree angle to reflect radiation from the

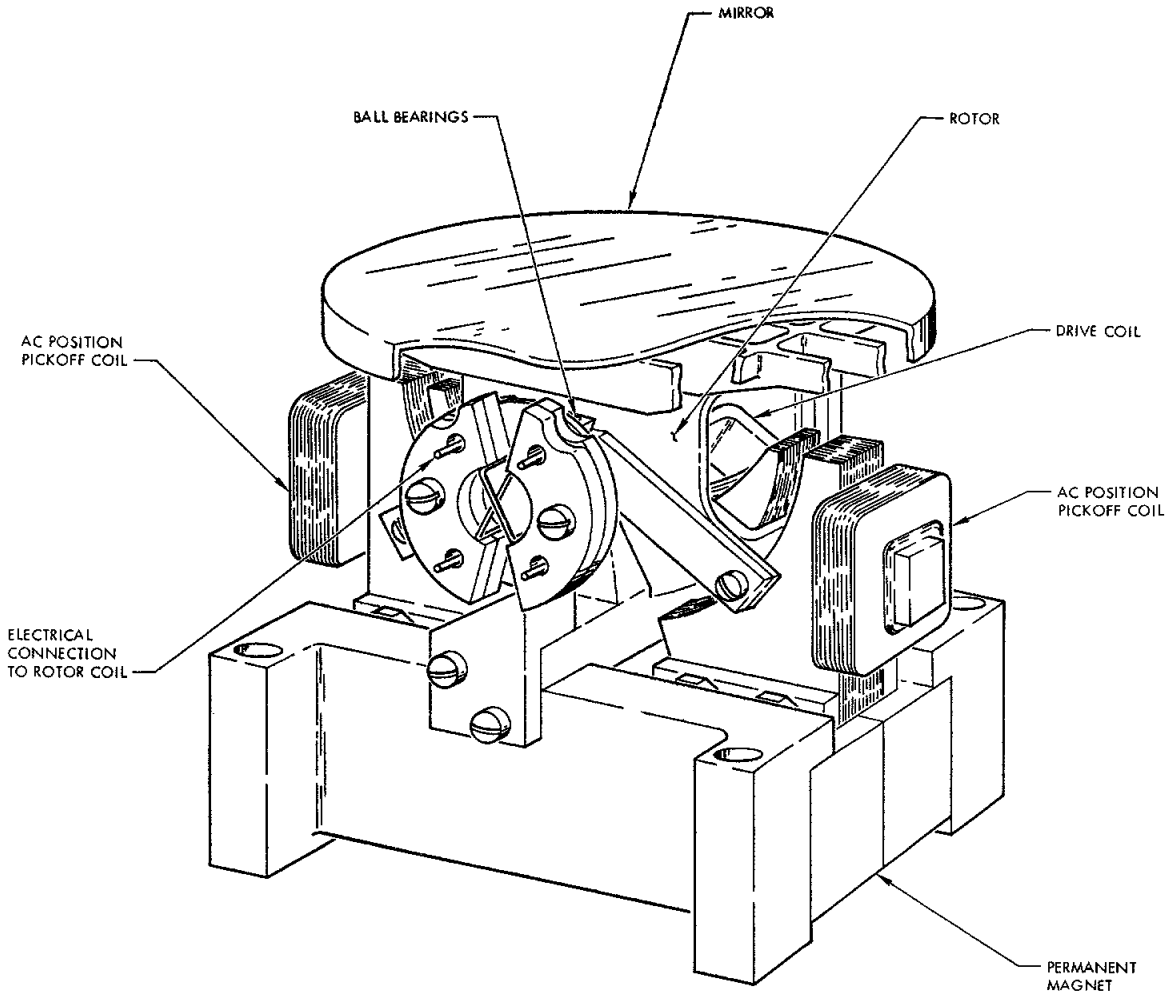
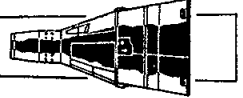

SINGLE-AXIS POSITOR

Figure 8-64 Horizon Sensor Single-Axis Positor



# PROJECT GEMINI



Positor mirror into the telescope. The germanium meniscus objective lens of the telescope is designed to focus incoming infrared radiation on the bolometer. The infrared filter, located immediately behind the objective lens, is designed to pass infrared radiation in the 8 to 22 micron range. The germanium immersed thermistor bolometer contains a culminating lens and two thermistors. The culminating lens directs all incoming radiation on one of the thermistors. The two thermistors are bonded to the rear of, and effectively immersed in, the culminating lens. Both thermistors are identical; however, one of the thermistors (active) is located at the focal point of the culminating lens. The other thermistor (passive) is located to one side of the focal point. The passive thermistor is used as an ambient temperature reference and does not react to direct infrared radiation.

## Signal Preamplifier

The signal preamplifier is a low noise, high gain, four stage, direct coupled transistor amplifier. The preamplifier is made in modular form and potted in epoxy for thermal conductivity and protection from shock and vibration.

## Position Detector

The position detector is a five kc phase detector designed to determine the position of the Positor mirror. The circuit produces a voltage which is proportional to the angle of the Positor mirror. Output of the detector is a dc voltage which varies at the same rate as the Positor mirror moves. The detector is made in modular form and potted in epoxy for thermal conductivity and protection from shock and vibration.



# PROJECT GEMINI

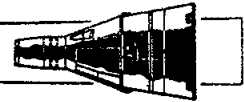

## Azimuth Drive Yoke

The azimuth drive yoke provides a means of moving the Positor mirror about its azimuth axis. The yoke is magnetically driven and pivots on ball bearings. The Positor is mounted inside the azimuth drive yoke and is rotated through an azimuth scan angle of  $160$  ( $\pm 80$ ) degrees by the yoke. The azimuth axis of rotation is through the center line of the infrared ray bundle on the surface of the Positor mirror. Drive coils, located directly in front of the yoke, supply magnetic impulses to drive the yoke. Mounted on the edge of the yoke (see Figure 8-60) are two iron slugs and a permanent magnet. The iron slugs are used to induce an overshoot signal in the azimuth overshoot detector. The permanent magnet is used to synchronously close contacts on three sync switches, mounted around the periphery of the yoke.

## ELECTRONICS PACKAGE

The electronics package (Figure 8-56) contains the circuitry necessary to control the azimuth yoke and Positor in the sensor head, as well as process attitude error signals. The package also contains a dc power supply and a five kc field current generator. The solid-state circuitry is made in modular form and potted in epoxy for thermal conductivity and protection from shock and vibration.

# RENDEZVOUS RADAR SYSTEM

## TABLE OF CONTENTS

TITLE	PAGE
SYSTEM DESCRIPTION . . . . .	8-235
SYSTEM OPERATION . . . . .	8-238
RADAR . . . . .	8-238
TRANSPONDER . . . . .	8-239
INTEGRATED OPERATION . . . . .	8-239
COMMAND LINK OPERATION . . . . .	8-241
SYSTEM UNITS . . . . .	8-243
RADAR MODULATOR AND TRANSMITTER . . . . .	8-243
TRANSPONDER ANTENNA . . . . .	8-245
SUFFICIENT AMPLITUDE DETECTOR . . . . .	8-247
TRANSPONDER CIRCULATOR . . . . .	8-247
RECEIVER . . . . .	8-247
TRANSPONDER MODULATOR AND TRANSMITTER . . . . .	8-254
RADAR RECEIVING ANTENNA SYSTEM . . . . .	8-255
GATE GENERATOR . . . . .	8-257
ELEVATION TWO-MICROSECOND MULTIVIBRATOR FUNCTIONS . . . . .	8-261
DITHER BISTABLE MULTIVIBRATOR FUNCTION . . . . .	8-261
SPIRAL ANTENNA IN ANGULAR MEASUREMENT . . . . .	8-261
DITHER SWITCHES . . . . .	8-263
RANGE AND RANGE RATE (R/R METER) . . . . .	8-263
RANGE SWEEP CIRCUIT . . . . .	8-265
DIGITAL RANGE COUNTER . . . . .	8-266
RADAR POWER SUPPLY . . . . .	8-267
TRANSPONDER POWER SUPPLY . . . . .	8-270

# PROJECT GEMINI

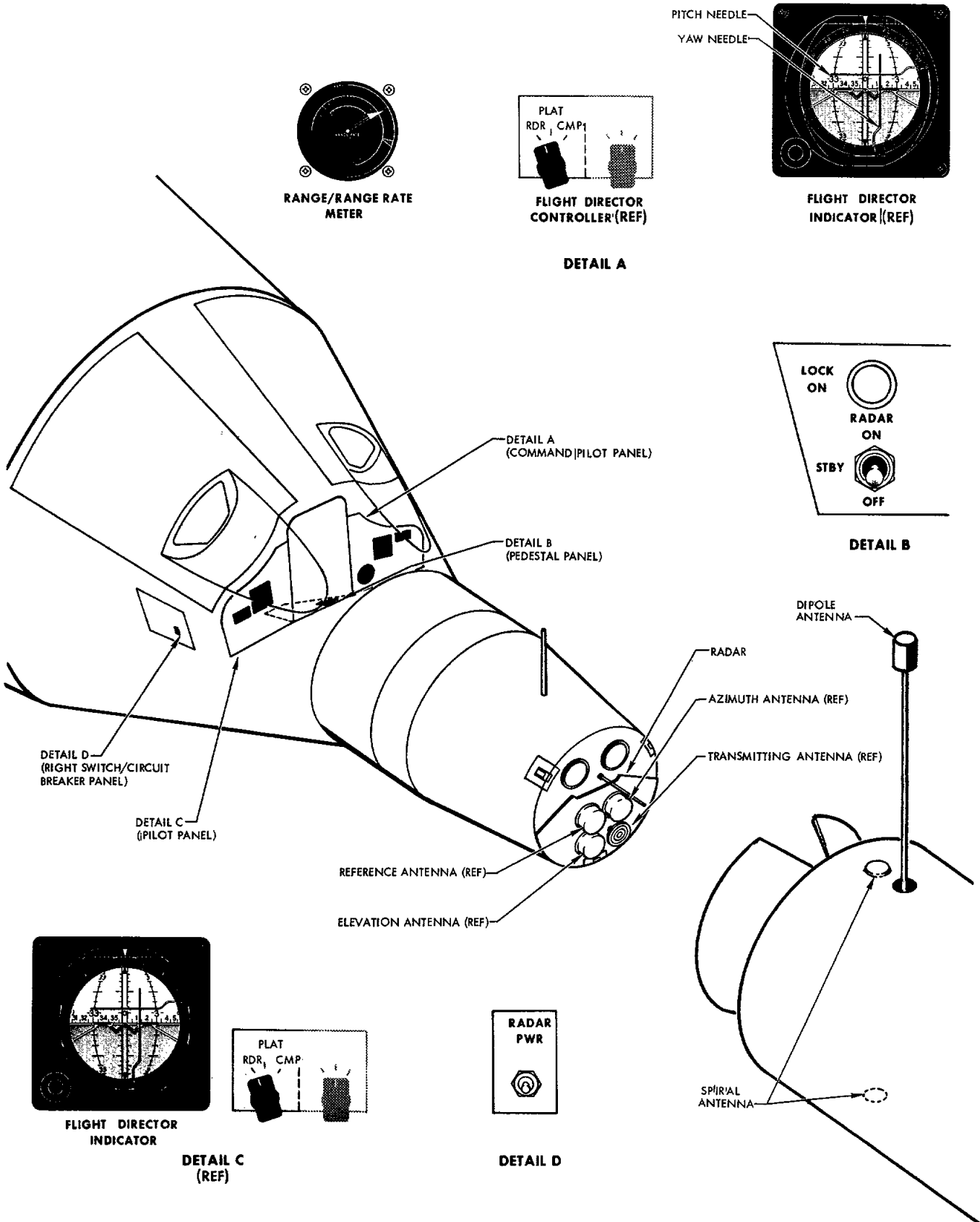
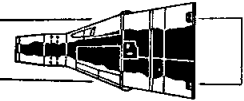

Figure 8-65 Rendezvous Radar System



# PROJECT GEMINI



## RENDEZVOUS RADAR SYSTEM

### SYSTEM DESCRIPTION

The Rendezvous Radar System (Figure 8-65) is incorporated in the Gemini Project to facilitate a rendezvous maneuver of the Gemini Spacecraft with the target vehicle. The system is comprised primarily of two units, a radar located in the rendezvous and recovery section of the Gemini and a transponder located in the target docking adapter of the target vehicle. The co-operative operation of the two units enables the detection of the target vehicle by the Gemini and the determination of the range, relative velocity, and angular relationship of the two craft. The radar transmission is also used as a carrier for the command link intelligence; refer to the command link portion of Section VIII for a description of this system.

The Rendezvous Radar System, as described herein is applicable to the rendezvous mission of spacecraft six and those planned for spacecrafts eight through twelve. Spacecraft five utilized a rendezvous evaluation pod to simulate the rendezvous mission. The difference between the rendezvous mission and the rendezvous evaluation mission will be discussed in the rendezvous evaluation pod portion of Section VIII.

The Rendezvous Radar System is capable of acquiring lock-on when the target vehicle is within 180 nautical miles of the Gemini and is within 8.5 degrees of the radar boresight axis. The angular acquisition capability increases to 25 degrees relative to the radar boresight when the range decreases to within 130 nautical miles. The radar provides bi-level, analog, and digital outputs for use during the catch-up and rendezvous portion of the Gemini flight (Figure 8-66). The Gemini crew is provided with visual indications of radar lock-on and Command

PROJECT GEMINI

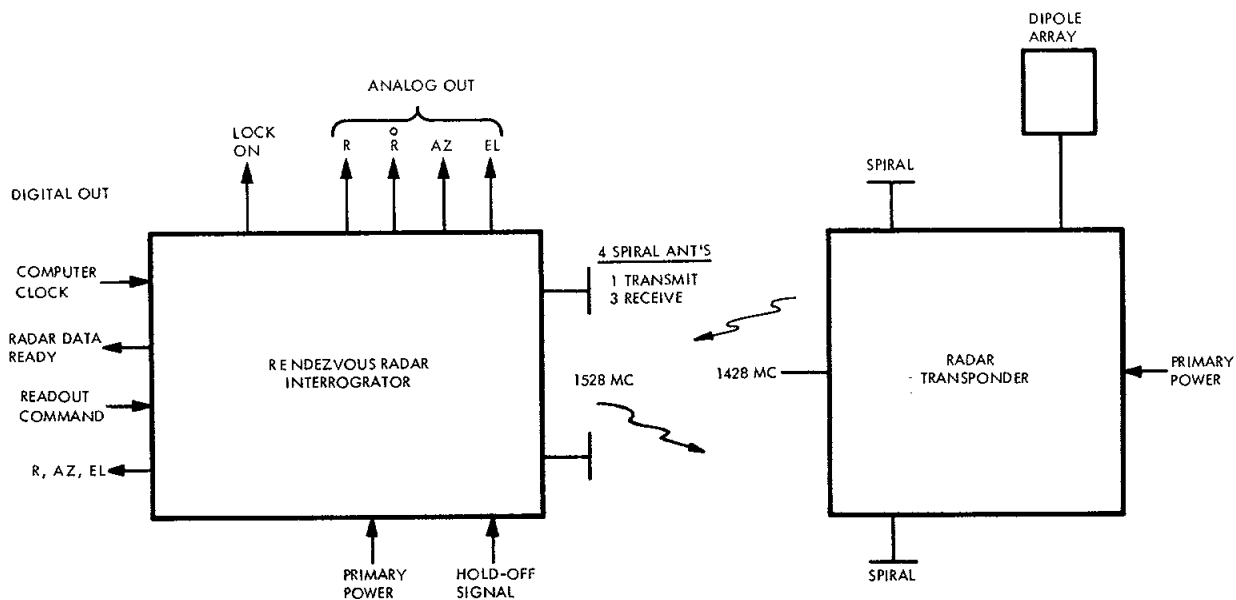

**RADAR**

**TRANSPONDER**

1. TRANSMITS A 1-USEC 1528 MC PULSE AT A PRF OF 250 PPS.
2. RECEIVES THE 6-USEC TRANSPONDER REPLY AND EXTRACTS RANGE, AZIMUTH, AND ELEVATION ANGLE INFORMATION FROM EACH PULSE.
3. PROVIDES ANALOG OUTPUTS TO THE INDICATORS REPRESENTING RANGE, RANGE RATE, AZIMUTH, AND ELEVATION.
4. PROVIDES BINARY DIGITAL OUTPUTS REPRESENTING RANGE, AZIMUTH, AND ELEVATION ANGLES TO THE COMPUTER, ON COMMAND.

1. RECEIVES THE INTERROGATING 1528-MC 1-USEC PULSES FROM THE RADAR; DELAYS 2-USEC AND TRANSMITS A 6-USEC PULSE AT A FREQUENCY OF 1428 MC FOR EACH PULSE RECEIVED.

Figure 8-66 Basic Functions of Rendezvous Radar System



# PROJECT GEMINI



Link message acceptance. Analog indications of the target vehicle range and differential velocity are presented on the Range and Range Rate Indicator. Analog indications of the elevation and azimuth position of the target vehicle, with respect to the Gemini, are presented on the flight director indicators. Digital indications of range, elevation, and azimuth are available to the computer for calculating the corrective thrusts required for the rendezvous maneuver.

The radar is contained within a pressurized module. The module dimensions are approximately 17 by 29 by 9 inches, the module area is 1.8 cubic feet, and the weight is 72 pounds. The radar is installed in the small end of the Gemini Spacecraft on the forward face of the Rendezvous and Recovery Section.

The radar antenna system consists of four spiral antennas, one uncovered transmit antenna and three covered receive antennas, mounted on the radar face plate. When installed in the spacecraft, the radar is covered with the nose fairing for thermal protection during the launch phase of the mission.

The transponder is contained within an unpressurized module. The module dimensions are approximately 9 by 10 by 2<sup>1</sup>/<sub>4</sub> inches, the module area is 1.25 cubic feet, and the weight is 3<sup>1</sup>/<sub>4</sub> pounds. The transponder is installed in the Target Docking Adapter of the target vehicle.

The transponder antenna system consists of one dipole and two spiral antennas electronically connected by coaxial cables. The dipole antenna is mounted on an extendable boom which is recessed until the extend command is given via the Digital Command System. The spiral antennas are mounted flush with the skin of the Target Docking Adapter and are mounted 180 degrees apart from each other.



# PROJECT GEMINI



## SYSTEM OPERATION

### RADAR

The rendezvous radar will, at the time of launch, be deenergized and the radar will be covered with the nose fairing for thermal protection. At staging plus 45 seconds the pilot will depress the JETT FAIRING switch, thereby jettisoning the nose fairing and exposing the radar.

During the initial portion of the orbital phase the spacecraft will maneuver to catch up with the target vehicle. This maneuver will place the Gemini and the target vehicle in co-planar, circular orbits. The Gemini will be lagging at a range of approximately 125 nautical miles and closing at a rate of approximately 1.5 nautical miles per minute. After completing the catch-up maneuver the Gemini crew will initiate radar transmission.

The radar is placed in the standby mode by switching the RADAR PWR circuit breaker, located on the right switch/circuit breaker panel, to ON and the RADAR switch, located on the main instrument panel center console, to STBY. Those systems with which the radar is interfaced are energized at this time. A time delay of 60 seconds is allowed for warm up prior to positioning the RADAR switch to ON. When turned ON, the radar commences transmission at a frequency of 1528 megacycles. The transmitted interrogation signal has a pulse width of 1 microsecond, a pulse repetition rate of 250 pulses per second for radars in spacecraft five, six, seven, eight, and nine, while those in spacecraft ten, eleven, and twelve operate at 240 pulses per second. The transmitter has a peak power output of 1150 watts.



# PROJECT GEMINI



## TRANSPONDER

The transponder will, at the time of launch, be deenergized and the extendable dipole antenna will be retracted. After the target vehicle enters the orbital phase the transponder is placed in a standby condition and the dipole antenna is extended via the Digital Command System. At this time the transponder is in standby and is connected to the dipole antenna. A sufficient amplitude detector is incorporated in the transponder, this circuit detects the initial pulses from the interrogate radar and enables the high voltage power supply. The period required for the transponder to become operational is approximately 12 interrogate pulses or 50 milliseconds. When the high voltage is energized the transponder is fully operational and will respond to the interrogate pulses of the radar.

## INTEGRATED OPERATION

The initial pulses of the radar will energize the transponder high voltage power supply. Now energized, the transponder responds to the radar at the interrogate pulse repetition frequency. The initial reply pulses from the transponder cause the illumination of the LOCK ON lamp.

The rendezvous radar determines the range to the transponder by observing the events which occur between radar transmission and receipt of the reply pulse from the transponder. This period of time is commenced by the time zero pulse, a pulse which occurs simultaneously with the leading edge of the radar transmission, and is terminated by the receiver video pulse, the detected transponder reply. The radar determines analog range by the initiation of a ramp voltage with the time zero pulse. The ramp voltage continues until stopped by the



# PROJECT GEMINI



leading edge of the transponder reply pulse. The ramp voltage is peak detected and the resultant dc voltage is proportional to the range. Succeeding pulses are differentiated to obtain the range rate. The radar analog range and range rate voltages are provided to the range and range rate meter and are, by means of a voltage divider, utilized for telemetry purposes. The radar measures digital range by counting the number of 50 megacycle computer clock pulses which occur during the range gate. The digital data is stored in the shift register for transmission to the computer.

The rendezvous radar determines the angular position of the target vehicle to the Gemini by observing the phase difference of the rf received at the reference antenna to the rf received at each of the two angle antennas. Each of the two angle antennas rotate to nullify the incoming phase difference. The amount of antenna rotation, from a zero position, required to achieve this result corresponds directly to the position error. An induction potentiometer and a Gray Binary Encoder, used to provide analog and digital intelligence, is connected to each of the antenna shafts. The analog angle information is provided to the flight director indicator needles of the attitude display group. The Gray binary information is converted to serial binary and stored in the shift register for transmission to the computer.

The radar digital range and angle data is stored in the shift register. The register stores a series of three readings which are continuously updated so as to indicate the latest information. The computer sends a radar data pulse to indicate a request for radar information. The shift register, after receiving the radar data pulse, obtains three complete radar readouts and discontinues



## PROJECT GEMINI



updating the information. The radar now transmits a data ready pulse. The computer, upon detecting that the radar data is ready, transmits a series of three bursts of 500 kc pulses to shift the radar data into the computer. The radar at this time returns to the state of continuous data updating.

### COMMAND LINK OPERATION

The radar is utilized during the rendezvous maneuver with the target vehicle as a carrier for the command link information. For information concerning this system refer to the command link portion of Section VIII. The operation of the radar, as a carrier, is explained herein.

The Command Link System, when energized, disables the radar pulse repetition frequency generator and interconnects the radar and the Time Reference System. The radar now operates at a pulse repetition rate of 256 pulses per second. The radar transmits data by pulse position modulation. The modulation is controlled by a portion of the Command Link System, the encoder. The normal pulse repetition time of 3900 microseconds is indicative of a zero; a one is transmitted by lengthening this time to 3915.2 microseconds.

The transponder received information is provided to the sub-bit detector, a portion of the Command Link System. The sub-bit detector converts the pulse position modulation to binary form and sends the message to the target vehicle programmer. The programmer verifies that an acceptable message is received and provides a message acceptance pulse to the transponder. The message acceptance pulse, when received by the transponder, causes the transponder transmitted pulse to lengthen from 6 to 10 microseconds and remain in this condition for three

# PROJECT GEMINI

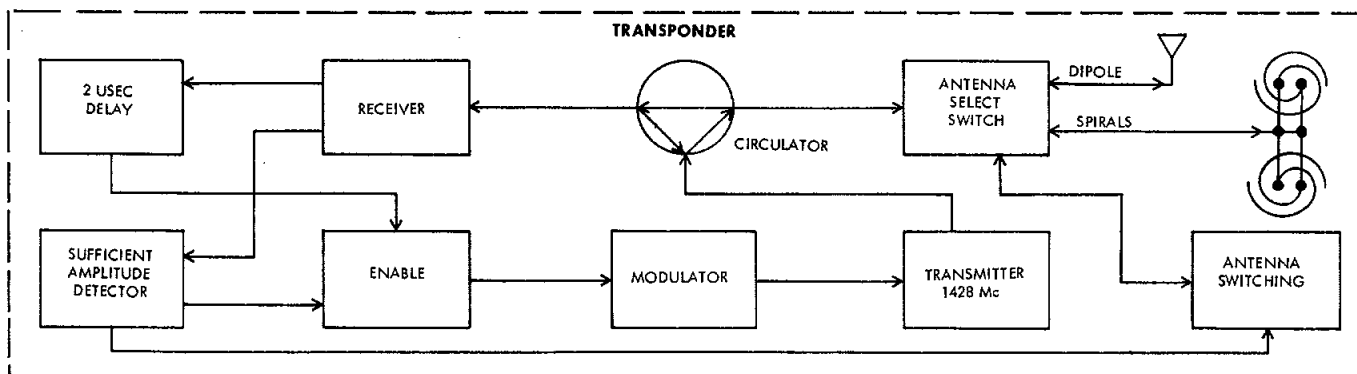
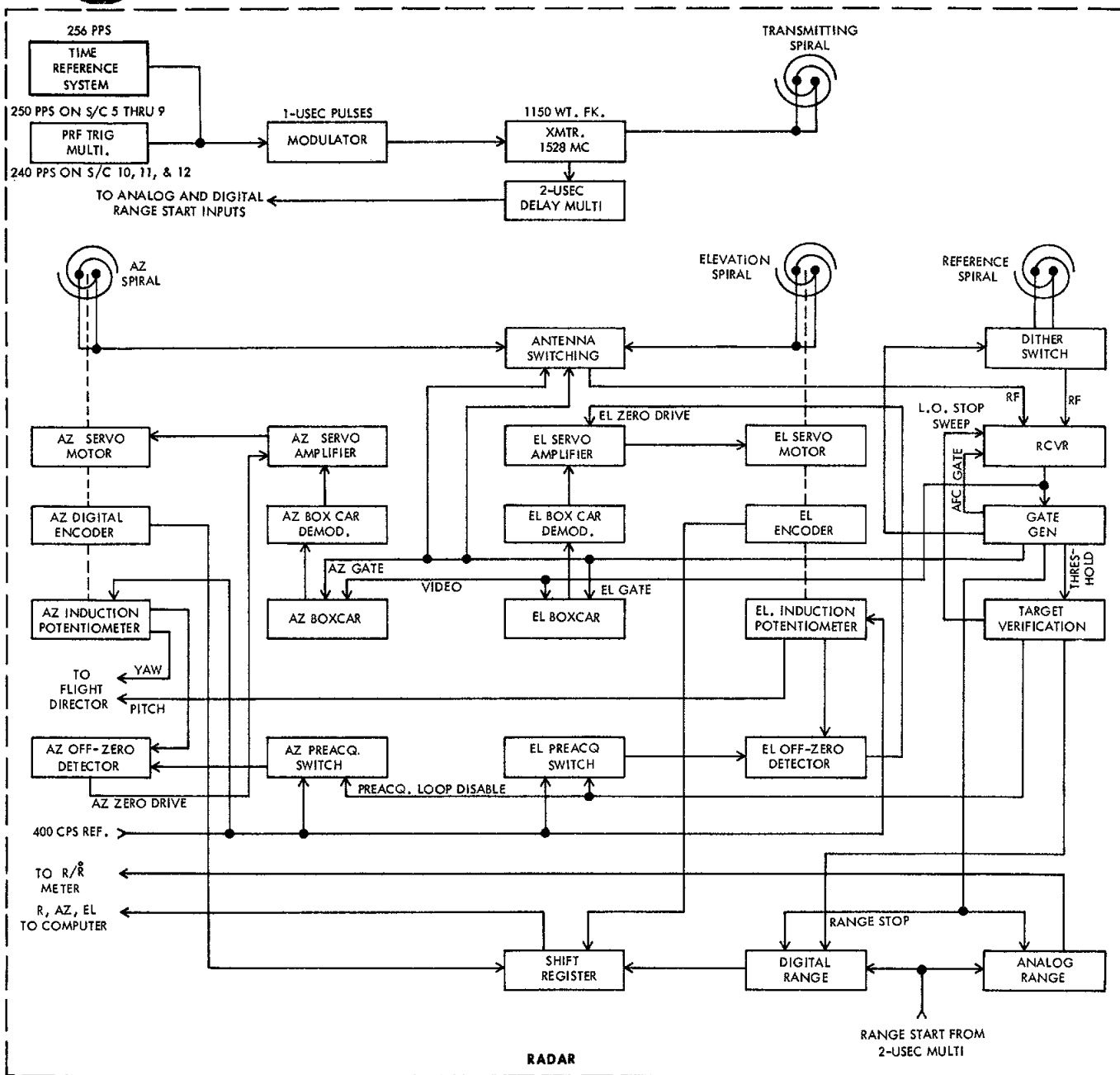

Figure 8-67 Rendezvous Radar System Block Diagram



# PROJECT GEMINI



transmissions. The radar detects the additional pulse width and effects the illumination of the Message Acceptance (MSG ACPT) lamp.

The previously described system operation affects only the radar pulse repetition frequency. This operation results in no alteration or interruption to the radar system.

## SYSTEM UNITS

### RADAR MODULATOR AND TRANSMITTER

When the RADAR switch is in the STBY position a hold off signal is applied to the high voltage portion of the radar power supply to prevent it from producing the high voltage required by the transmitter tube. When the pilot places the RADAR switch to the ON position, (Figure 8-67) the hold off signal is removed, the 1650 volts dc is produced and applied to the transmitter tube, and the radar commences transmitting in the search mode. In the search mode the pulse repetition frequency trigger multivibrator oscillates at 250 cycles per second for radars on spacecraft five, six, seven, eight and nine, while on spacecraft ten, eleven, and twelve the trigger multivibrator oscillates at 240 cycles per second, generating a square wave which is used to trigger the modulator.

The modulator output is a series of one microsecond positive pulses which triggers the transmitter tube. The transmitter tube output is a 1528 megacycle, 1 microsecond, 1150 watt pulse at a repetition rate equal to the output of the pulse repetition frequency trigger multivibrator. The transmitter output pulse is coupled to the transmitting dual spiral antenna and radiated in order to interrogate the transponder.

# PROJECT GEMINI

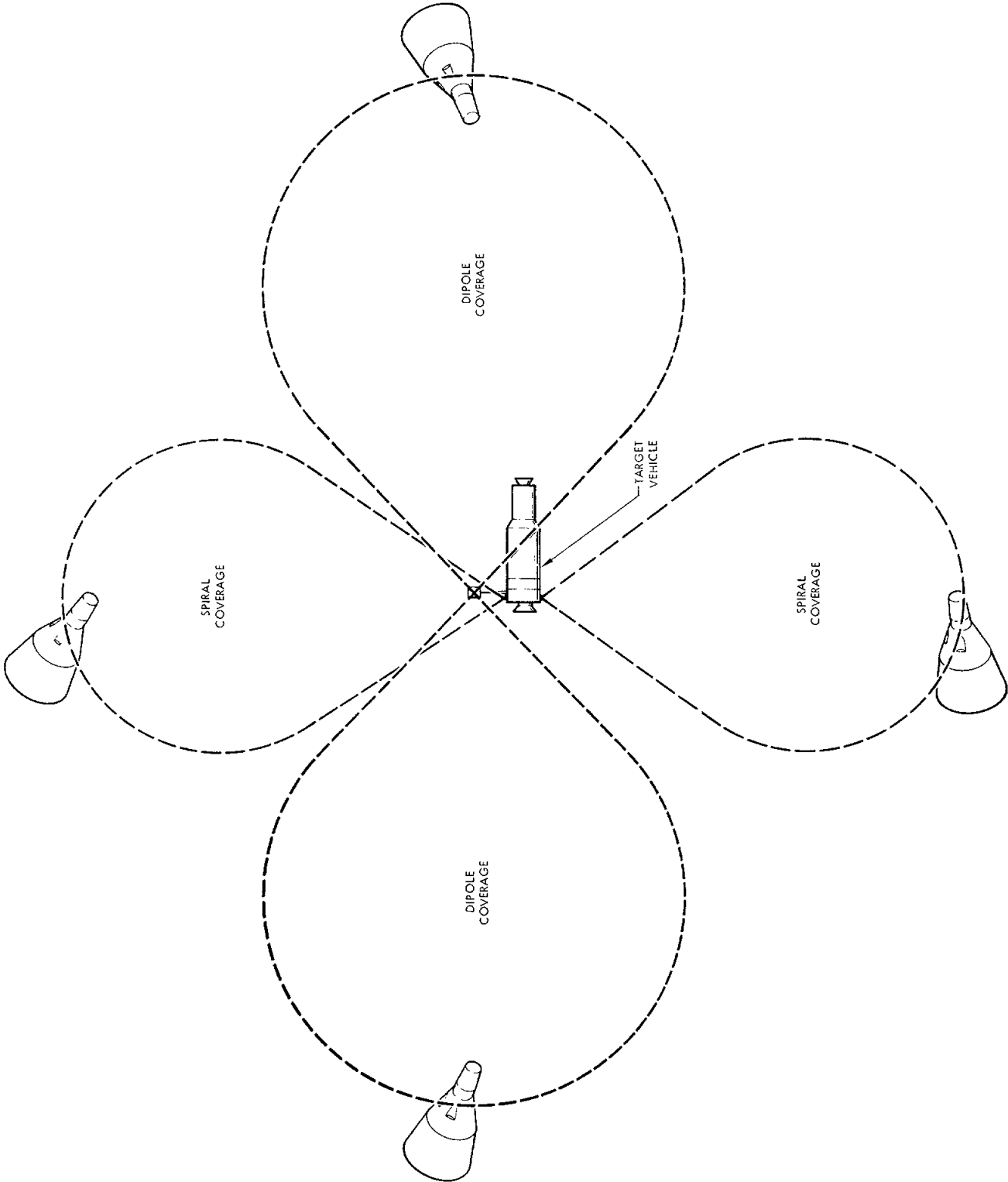
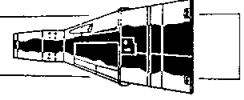
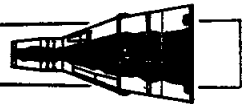

Figure 8-68 Transponder Antenna System Coverage



# PROJECT GEMINI



## TRANSPONDER ANTENNA

The transponder utilizes two antenna systems, (Figure 8-68) a dipole antenna array and two dual spiral antennas. The selected antenna system is connected to the transponder by an antenna select switch. The dipole antenna array is located on an extendable boom which is retracted until after the target vehicle enters the orbit phase of the mission. The spiral antennas are located on either side of the Target Docking Adapter and are mounted flush with the surface of the adapter (Figure 8-65).

The dual transponder antenna systems are designed to provide spherical coverage about the target vehicle. The dipole will provide omnidirectional coverage in the horizontal plane. The dipole pattern is doughnut shaped with the dipole located in the center. The beam width considered in any horizontal direction is plus or minus 25 degrees at the half power points. The array has a minimum gain of 3.5 db. In order to provide effectively spherical coverage the spirals will operate in the space above and below the dipole pattern. The spiral beam width is plus or minus 35 degrees and the minimum gain of each spiral is 7.5 db.

The initial condition of the transponder will be with the internal circuitry connected to the dipole array and the spiral antennas disconnected. The dipole array is selected since this provides coverage for the anticipated acquisition area. The initial radar pulses received by the transponder enables the sufficient amplitude detector. The detector turns on the high voltage required for transmitter operation, thereafter it monitors the received signal to ensure adequate strength. Should the signal level decrease below a specific level the detector causes the transponder to switch to the opposite antenna system in search of greater strength.

# PROJECT GEMINI

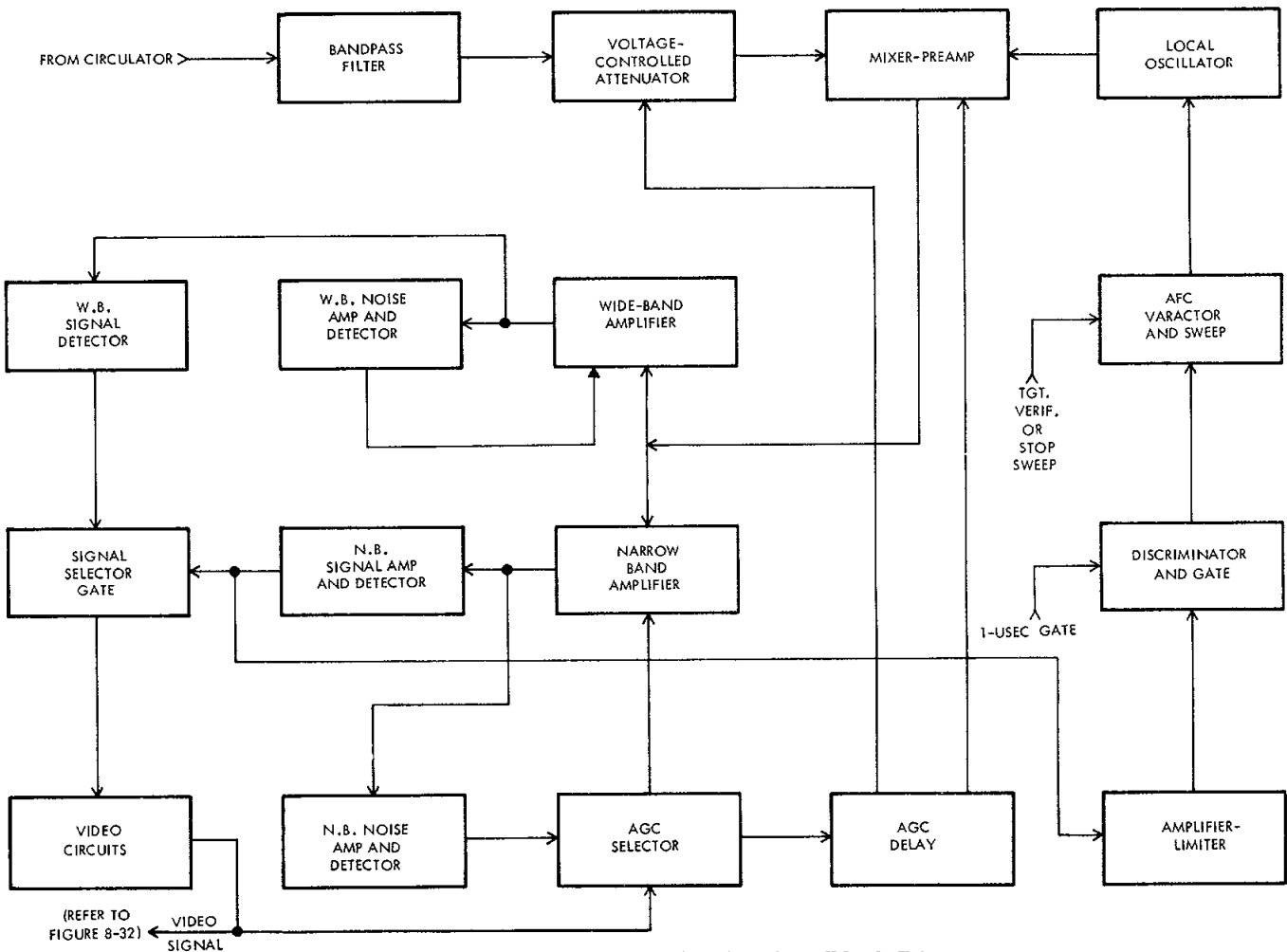
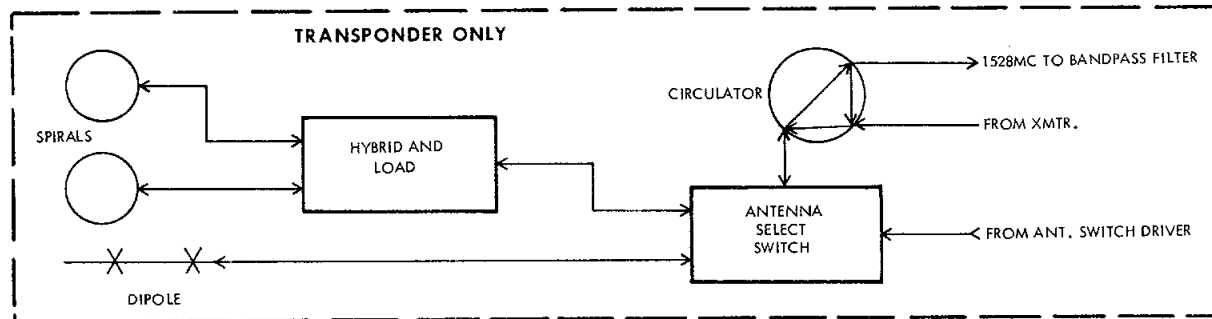
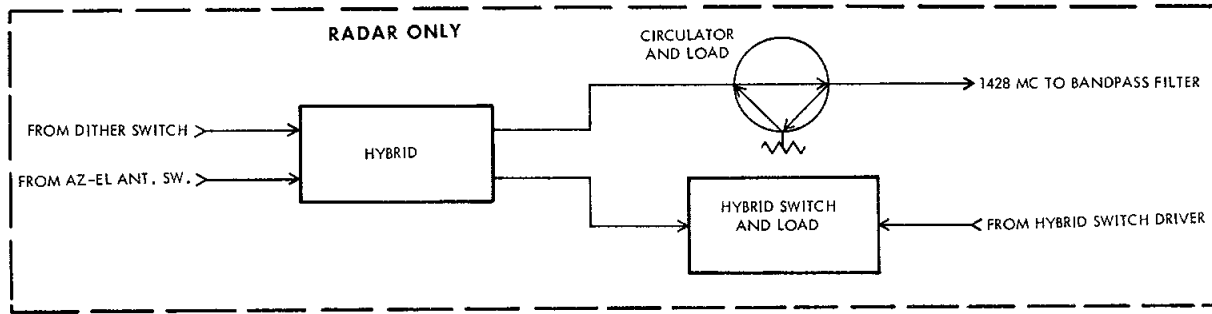
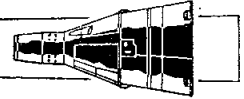

Figure 8-69 Radar/Transponder Receiver Block Diagram



# PROJECT GEMINI



## SUFFICIENT AMPLITUDE DETECTOR

The signal from the transponder video circuit is applied to the Sufficient Amplitude Detector (SAD). During the initial portion of the mission, when the transponder is in standby, the SAD monitors the antenna system for the initial interrogate pulse from the radar. When the first pulses are received it places the transponder in the transmit mode by activating the high voltage. While the transponder is operating the SAD monitors the received signal strength; if it decreases below a specific level it selects the opposite antenna system in order to seek greater signal strength. Should the interrogate signal be lost, the SAD causes the transponder to continually cycle from one antenna system to the other until lock-on re-occurs.

## TRANSPONDER CIRCULATOR

The transponder circulator (Figure 8-67) is a transmit/receive device which permits the receiver and transmitter to operate by the same antenna. The circulator provides a low attenuation path for the rf from the transmitter tube to the antenna and a low attenuation path from the antenna to the receiver. The directivity of the circulator provides a high attenuation and enables the blocking of the main bang from the receiver.

## RECEIVER

The transponder and radar receivers (Figure 8-69) are practically identical in most respects. There are some differences, principally in the input circuit. The receiver will be explained in the following way. The difference in the input circuitry will be discussed first, then the portion of the receiver from the bandpass filter to the video circuits output. Automatic frequency control and automatic gain control will conclude the discussion of the receiver.



# PROJECT GEMINI



## Radar Receiver Input

Figure 8-67 shows the three receiving spiral antennas and the manner in which the rf is connected to the receiver. As will be discussed later in the radar receiving antenna system paragraph, the radar compares phase relationships on two receiving antennas at a time during each return pulse. Because the radar compares phase relationships while the transponder does not, the input circuits are different. The two rf signals being compared in phase are combined in the hybrid (Figure 8-69). The signal path of the combined rf is through the circulator, the bandpass filter, the voltage controlled attenuator and into the mixer. The load associated with the radar circulator is required because of the voltage controlled attenuator. (Refer to the discussion of the voltage controlled attenuator below, where its operation in both receivers is explained.) The load associated with the radar hybrid switch is explained in the gate generator discussion.

## Transponder Receiver Input

As Figure 8-69 shows, both spirals are connected to a hybrid. Since only one spiral at a time will be directed toward the radar, the signal received on either one will pass through the hybrid to the antenna select switch. The signal is passed through the circulator, the bandpass filter, and the voltage-controlled attenuator to the mixer. The loads associated with the transponder hybrid are required for equal power division in the hybrid. If neither spiral was directed toward the radar, the signal would be received on the dipole, passed through the antenna select switch and on to the mixer in the same way as was described for the spiral.



# PROJECT GEMINI



## Bandpass Filters

The bandpass filters in the transponder and the radar are identical; however, the frequencies to which they are tuned are different. Each filter is tuned at the transmit frequency of the other unit. The radar is tuned to 1428 megacycles and the transponder is tuned to 1528 megacycles. These filters provide the required interference rejection and help keep the transmitter main bang out of the receiver.

## Voltage-Controlled Attenuators

The voltage controlled attenuators in the radar and the transponder are identical. The purpose of the attenuator is to prevent saturation of the mixer by holding the mixer input to a minus 12 dbm maximum. The attenuator is inoperative at far and middle ranges. Operation commences as the range decreases and the power at the receiver increases. The attenuator is a solid-state device with a maximum attenuation of 24 db. The attenuation is controlled by a delayed automatic gain control voltage which varies from 0 to minus 6 volts.

The voltage-controlled attenuator produces attenuation by impedance mismatching. In the radar, the impedance mismatch tends to reflect the wave back to the input, which is the circulator. Due to the directional characteristic of the circulator described earlier, the reflected wave will not back up through the circulator the same way it enters. The path that the reflected wave takes through the circulator terminates in a load resistance; thus the reflected wave is prevented from becoming a standing wave. This precaution is taken in the radar because standing waves could upset stability and render the angular measurements inaccurate.



# PROJECT GEMINI



The voltage-controlled attenuator in the transponder functions in a similar manner; however, standing waves are not avoided. Never the less, attenuation is effective, and the mixer is prevented from saturating. Since no critical measurements are made in the transponder the standing waves produce no unfavorable effects.

## Automatic Frequency Control (AFC)

The automatic frequency control circuit in the transponder and radar is comprised of the local oscillator, the mixer preamplifier, the narrow band amplifiers and detector, the amplifier limiter, the discriminator and gate, and the AFC varactor and sweep circuit (Figure 8-69). The varactor, a solid-state voltage-controlled variable capacitor, is the heart of the AFC circuit. A 0.2 cycle per second sweep voltage is applied to the varactor when the receiver is turned on. This voltage causes the local oscillator frequency to vary over a 1-megacycle band about its operating frequency.

In the transponder, when the 1528 megacycle interrogation pulse is received, it is applied to the mixer. Here the 1557.5 to 1558.5 megacycle output of the local oscillator beats with it, and the 30 megacycle Intermediate Frequency (IF) is produced. The IF is applied to the wide band and narrow band amplifiers. The signal selector gate initially selects the narrow band output since it is larger. Five pulses in 16 milliseconds produce the stop sweep pulse which ends the local oscillator sweeping. This prepares the varactor to be controlled by the discriminator. The narrow band signal is amplified, limited, and discriminated. If the video exceeds the predetermined threshold, a 1 microsecond pulse is supplied which opens the discriminator gate and allows the discriminator output to control

# PROJECT GEMINI

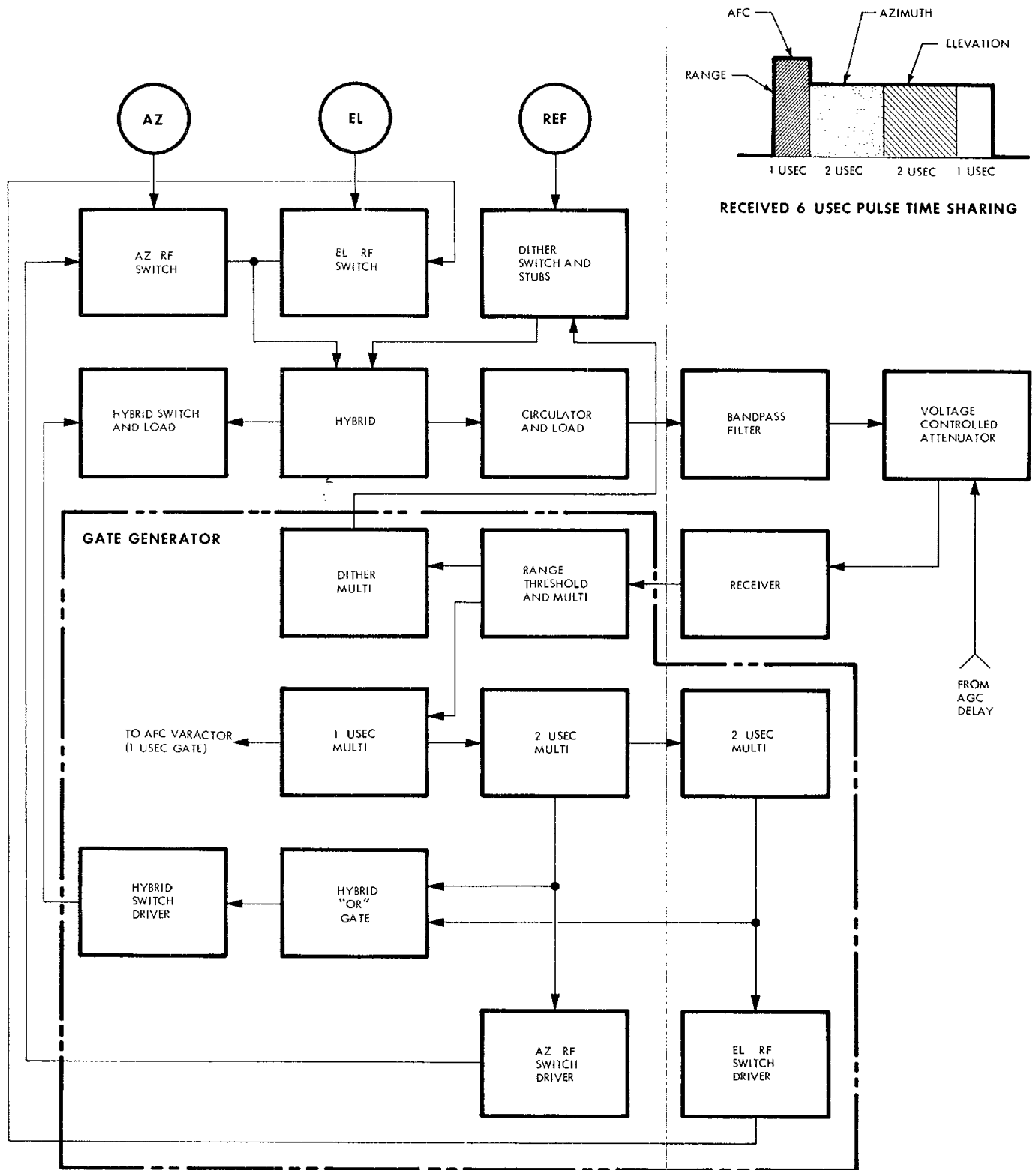
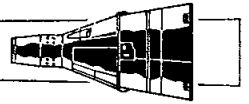

Figure 8-70 Radar RF Switching and Return Pulse Time Sharing



## PROJECT GEMINI



the varactor. The discriminator increases the frequency if it is low, decreases it if it is high. There is no output from the discriminator when the IF is exactly 30 megacycles.

In the radar, when the 1428 megacycle return pulse is received, the 1457.5 to 1458.5 megacycle output from the oscillator beats with it. Twelve pulses in 48 milliseconds are required to produce the target verification pulse which stops the varactor sweep. The 1 microsecond multivibrator (Figure 8-70) produces the discriminator gate which enables the discriminator to control the varactor. The IF is maintained to 30 megacycles.

### Automatic Gain Control (AGC)

Receiver gain in both the radar and the transponder must be adjusted automatically to accommodate a wide range of input signal levels. Figure 8-71 shows how the narrow and the wide band channels are controlled by noise levels, input signals, and range. The narrow band channel has 14 db higher gain than the wide band channel. Since the signal selector gate (Figure 8-69) will select the higher output to operate the video circuits, the narrow band circuit will have control at the distant ranges. Narrow band gain will be controlled by the narrow band noise feedback voltage. When the narrow band signal assumes control of the narrow band gain, the outputs of the narrow band noise detector and signal detector are both applied to the AGC selector. The AGC selector controls the narrow band gain. The wide band signal has also been increasing with the input signals and the decreasing range. As the side-band signal reaches the predetermined level, it is selected by the signal selector gate and assumes control. The wide band signal applied to the AGC selector along with the

# PROJECT GEMINI

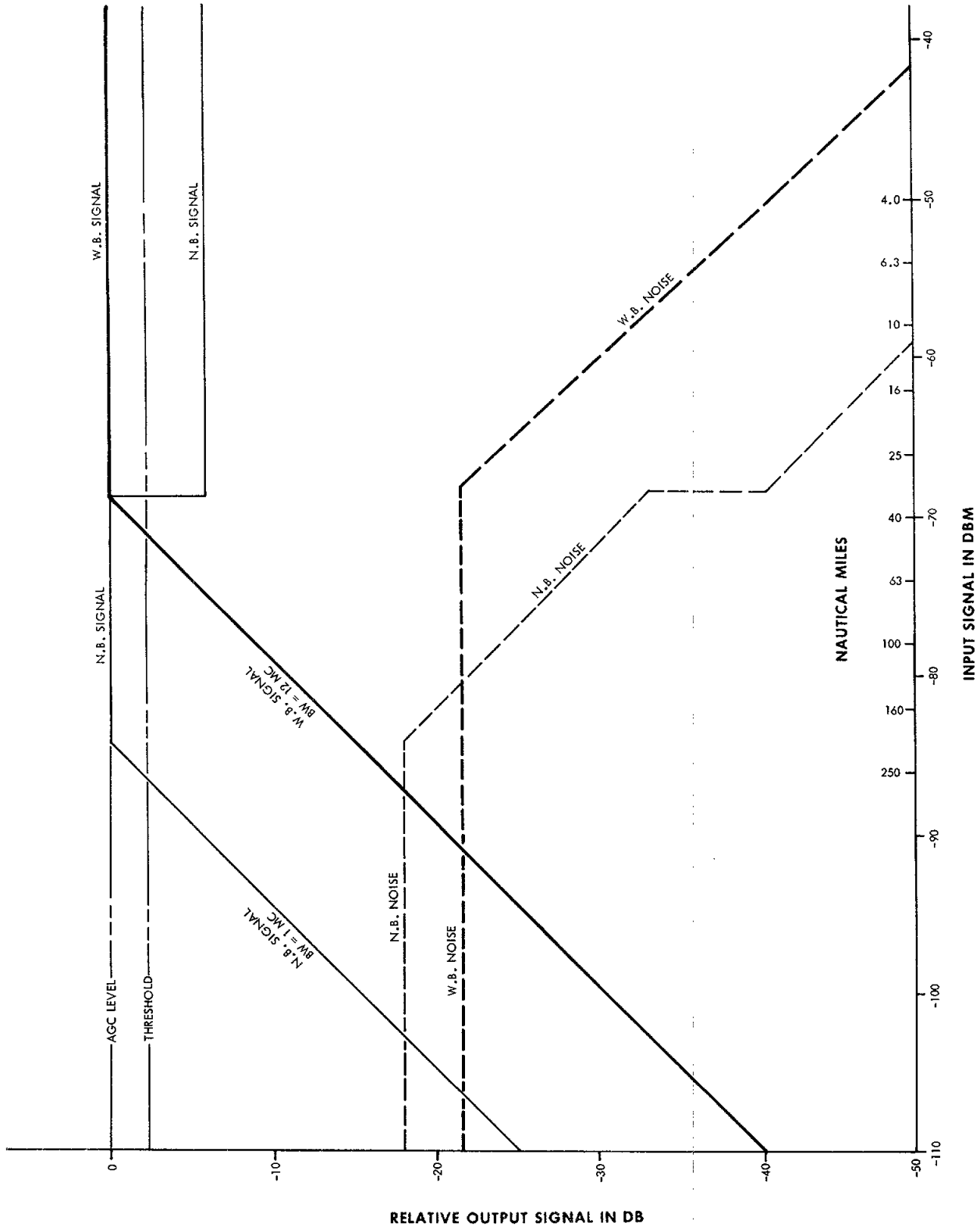
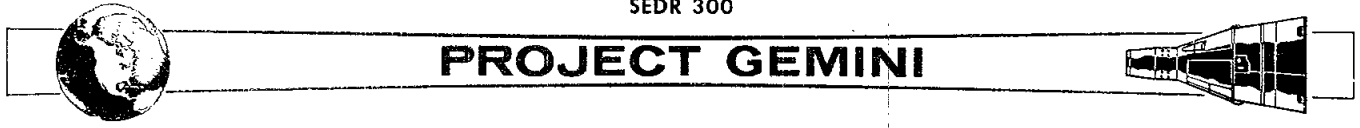
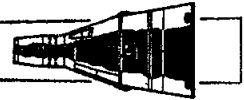

Figure 8-71 Receiver Operation Versus Range

8-253



# PROJECT GEMINI



narrow band noise detector output further reduces narrow band gain and narrow band noise. As range continues to diminish and input signal to increase, a greater AGC voltage is developed to hold the signal at the predetermined level. The AGC delay is overcome and AGC is applied to the voltage-controlled attenuator and the mixer preamplifier at near range. AGC in these receivers is capable of maintaining a constant output level with input signals weaker than -83.3 dbm at 160 nautical miles to signals of +12 dbm at a range of 20 feet.

## TRANSPONDER MODULATOR AND TRANSMITTER

The transponder transmitter is placed in the standby mode by the uhf command link. A hold off signal is applied to the high voltage portion of the transponder power supply to prevent it from producing the high voltage required by the transmitter tube. The initial interrogate pulses from the radar surpass the threshold of the sufficient amplitude detector and cause the removal of the hold off signal. The 1590 volts dc is produced when the signal is removed and the transmitter commences transmitting. In the transmit mode the interrogate pulse from the radar is received at the transponder, delayed for 2 microseconds, and used to trigger the modulator. The modulator output is a 6 microsecond positive pulse which triggers the transmitter tube. The transmitter output is a 1428 megacycle, 6 microsecond, 1150 watt pulse at the interrogate pulse repetition frequency. The transmitter output pulse is coupled through an rf switch to either the pair of spiral antennas or the dipole antenna array and radiated.



# PROJECT GEMINI



## RADAR RECEIVING ANTENNA SYSTEM

### Antenna System Description

The radar receiving antenna system consists of three dual spiral antennas 6.5 inches in diameter. The receiving antennas, along with the transmitting antenna, form a square array spaced 0.82 wave length apart. The three receiving antennas are: the azimuth antenna, the elevation antenna, and the reference antenna. The azimuth and elevation antennas are rotatable and are pressurized to aid lubrication in the space environment. They are returned to zero rotation by a preacquisition loop. The reference antenna and the transmitting antenna do not rotate and are not pressurized. The spirals are raised about a quarter wave length ( $2-1/8$  inches) above the radar face plate, and have a circumference of 2.4 wave lengths (20.5 inches). Their characteristic impedance is 75 ohms. The receiving antennas are operated in pairs, using the reference antenna as the common element, to measure the target bearing angle. The radar uses time sharing of the 6-microsecond return pulse, interferometer measurement techniques, and phase dither to obtain complete tracking information.

### Azimuth and Elevation Antenna Zeroing

The amount that the azimuth and/or elevation antenna is rotated is the measure of target position. When the radar is tracking a target and these antennas are following the target's changing position, lock on may be interrupted. When this happens, it is desirable to return the antennas to zero rotation. A circuit called the preacquisition loop is provided to do this when the target pulse is not being received. The loop consists of the preacquisition switch, a 400 cps reference voltage, output from the induction potentiometers, a detector, the servo amplifiers, and the servo motors.



# PROJECT GEMINI



The loop compares the output of the induction potentiometer with a 400 cps reference voltage. If the antenna is off zero, an error voltage is produced in the detector output. The error voltage drives the servo amplifier which turns the servo motor. As the rotation angle decreases, so does output of the induction potentiometer; and when the potentiometer output is zero the error voltage and the rotation angle are zero. As soon as lock on is established, this loop is disabled by the target verification signal.

## Return Pulse Time Sharing

There is a reason why the transponder transmits a 6 microsecond pulse in reply to 1-microsecond interrogation pulse. If only range data and automatic frequency control voltages were obtained from the pulse a similar 1 microsecond pulse would be wide enough; but the azimuth and elevation angle of the target must be obtained from the same pulse. The interferometer technique of angular measurement (which will be described later) required that two antennas in the horizontal plane receive the return signal. The signal on the two horizontal antennas must be present for an interval long enough to compare their phase relationship. Next, two antennas in the vertical plane must receive components of the return signal long enough to compare their phase relationship. In this system, the optimum interval for the phase comparison is 2 microseconds. For this reason the transponder sends back a 6-microsecond pulse.

## Pulse Division

The return pulse must be divided into 3 parts each time it is received. (Figure 8-70). The first part, one microsecond, will be used for range measurement and automatic frequency control of the local oscillator and receiver inter-



# PROJECT GEMINI

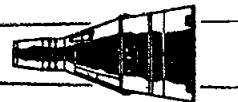

mediate frequency. The second part will be used for azimuth angular measurement, and the third part will be used for elevation angular measurement. The first interval will be made 1 microsecond; the second and third, 2 microseconds each. These intervals add up to 5 microseconds; the remaining 1 microsecond is not used.

## GATE GENERATOR

The key circuit which controls pulse division, switching and time sharing is the gate generator. Figure 8-70 illustrates how the gates which perform the required switching are generated. To understand the switching that is done, the gates that are generated and used, and how the return pulse time is shared, it is necessary to know the static conditions before the pulse is returned, the return signal path, and the sequence in which the gates and switches operate.

### Static Conditions Before Arrival of Return Pulse

While the radar is waiting for the return pulse from the transponder, the following conditions prevail: The azimuth RF switch, the elevation RF switch, and the hybrid switch are open. The open azimuth and elevation switches prevent rf, which arrives on these antennas, from being connected to the hybrid and receiver. Thus this rf cannot be mixed with the reference antenna rf until the proper gate voltage is applied. The open hybrid switch keeps the hybrid load disconnected from the hybrid. The dither switch is closed in one of its two positions. All of the multivibrators (except the dither bistable multivibrator) are one-kick multivibrators, and in the quiescent state. They are waiting for the return pulse to trigger them in succession.



## PROJECT GEMINI



### Return Signal Path

The reference antenna is the only receiving antenna initially connected to receive the return pulse. Following the arrows from the reference antenna to the input to the gate generator on Figure 8-70, the signal flow is as follows. The 6-microsecond pulse enters the reference antenna and flows through the dither switch and selected stub, the hybrid, the circulator, the bandpass filter, the voltage-controlled attenuator, and the receiver, and enters the gate generator.

### Gate and Switching Sequence

When the transponder pulse arrives at the antenna system, it enters the reference antenna and follows the described path to the gate generator. Here, it is applied as a 6-microsecond video pulse to the range threshold and multivibrator. If the pulse amplitude is large enough, the leading edge of the video pulse triggers the multivibrator. Then the whole process of gating and switching begins.

### Range Threshold Multivibrator Functions

The on-period of the range threshold multivibrator is 12 microseconds. This threshold multivibrator has four functions: First, the leading edge of this 12 microsecond pulse terminates the range measurement in both the digital and analog range circuits. Second, five of these pulses are integrated by the target verification circuit to produce the target verification signal. The target verification signal stops the AFC sweep (Figure 8-69), and disables the preacquisition loop. Third, the leading edge of the threshold multivibrator output has no effect on the dither bistable multivibrator. The dither multivibrator and switch remain locked in position throughout the return pulse. Fourth, the one-microsecond multivibrator is triggered by the leading edge of the threshold multivibrator output.



# PROJECT GEMINI



## One-Microsecond Multivibrator Functions

The 1-microsecond multivibrator has three functions: First, it gates the discriminator output into the AFC varactor (Figure 8-69). This gate permits the output of the discriminator to continually correct the local oscillator frequency to 1458 megacycles. Second, the 1-microsecond gate is applied to the azimuth and elevation boxcar detectors simultaneously. The gate dumps the charges built up in these detectors during the preceding sampling interval. Third, the trailing edge of the 1-microsecond gate triggers the 2-microsecond multivibrator.

(Figure 8-70)

## Azimuth Two-Microsecond Multivibrator Functions

The 2-microsecond pulse generated by the azimuth multivibrator is the azimuth gate. This gate performs five functions: First it excites the azimuth rf switch driver. The driver closes the azimuth rf switch. The switch connects the azimuth antenna to the hybrid (Figure 8-70). Second, the gate enters the hybrid or gate and excites the hybrid switch driver. The driver closes the hybrid switch. The switch connects the load during the azimuth angle measurement. This load flattens the line and prevents standing waves from producing erratic measurements. Third, the gate permits the video received during this interval to develop a charge voltage in the azimuth boxcar detector (Figure 8-72). The charge voltage is later demodulated to provide the control voltage for the azimuth servo motor. Fourth, when the azimuth gate ends, the azimuth rf switch is opened. The switch disconnects the azimuth antenna (Figure 8-70). Fifth, the trailing edge of the azimuth gate triggers the elevation 2-microsecond multivibrator.

PROJECT GEMINI

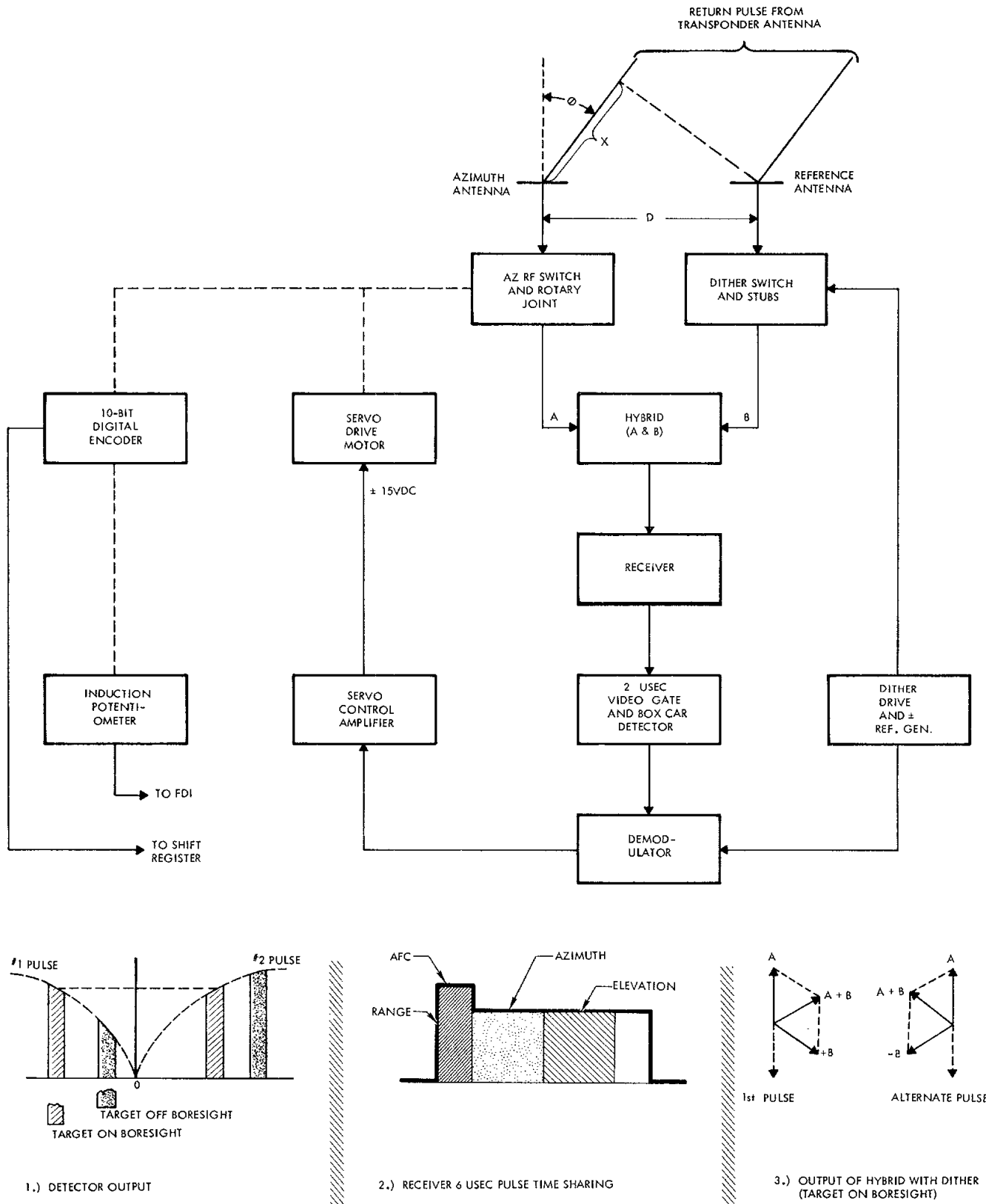

Figure 8-72 Interferometer Measurement of Target Angle



# PROJECT GEMINI



## ELEVATION TWO-MICROSECOND MULTIVIBRATOR FUNCTIONS

The output of the multivibrator is the elevation gate. It performs five functions: First, it keeps the hybrid switch closed and the load applied to the hybrid. Second, it closes the elevation rf switch and connects the elevation antenna to the hybrid. Third, it permits the video received during this interval to charge the elevation boxcar detector. This voltage charge is later demodulated to become the control voltage for the elevation servo motor. Fourth, the end of the azimuth gate opens the elevation rf switch and disconnects the elevation antenna. Fifth, the end of the gate also ends the drive to the hybrid switch and disconnects the hybrid load.

## DITHER BISTABLE MULTIVIBRATOR FUNCTION

The dither bistable multivibrator has one function: to change the position of the double-pole double-throw dither switch. The dither multivibrator is insensitive to the leading edge of the 12-microsecond threshold multivibrator pulse. However, the trailing edge of this pulse will trigger the dither multivibrator. Hence, the dither switch and stub are changed 6 microseconds after every return pulse ends.

## SPIRAL ANTENNA IN ANGULAR MEASUREMENT

### Interferometer Measurement of Angular Displacement

The method of measuring angular displacement employed in the Rendezvous Radar System uses rf waves from a point source, the operating transponder antenna (Figure 8-72). These waves are received simultaneously by two of the three spiral receiving antennas of the Rendezvous Radar. The length of the rf path to the reference antenna is compared first with the length to the azimuth antenna, then with the length to the elevation antenna. The transmission lines



## PROJECT GEMINI



from the three receiving antennas are wired so that rf voltage induced in the azimuth and elevation antennas will be 180 degrees out of phase with rf voltage induced in the reference antenna, if the transponder is on the radar boresight axis. The sum of two compared voltages will be zero. If, however, the transponder is off the boresight axis, in azimuth for instance, the path lengths to the reference antenna and to the azimuth antenna will be different. Therefore, the phase difference between the RF voltage induced in the two antennas will not be 180 degrees. As a result, there will not be complete cancellation (or a null) as before. A voltage proportional to the displacement from the boresight axis will result. This voltage is called the error voltage.

### Spiral Rotation Nulls Error Voltage

The method used to null out the error voltage constitutes the interferometer method of angular measurement. This method depends upon a peculiarity of the spiral antenna. The spiral antenna shifts the phase of the rf voltage induced in it as it is rotated about its center. Therefore, the 180-degree phase difference between the azimuth and reference antennas can be obtained by rotating the azimuth antenna. The amount of azimuth antenna rotation required to get the null is proportional to the target displacement in azimuth. If the error voltage is used to drive a motor which rotates the azimuth antenna, then when the null is reached, the error voltage is zero, and the motor stops rotating. The antenna also stops rotating. If a sensing device is put on the azimuth antenna which counts the angular mils of rotation or generates a voltage proportional to the rotation, a digital or analog measure of the target's angular displacement in azimuth from boresight is provided. Figure 8-72 shows that this is what is done. Displacement in elevation is measured in a similar manner.



# PROJECT GEMINI



## DITHER SWITCHES

Interferometer measurement of target angle does not yield direction data. Interferometer measurement tells how much the target is off the boresight axis but not in which direction. To establish target direction, dither is added.

### Dither Senses Angular Direction

The phase dither circuit contains two single-pole, double throw diode switches and two different lengths of transmission line, called stubs. The diode switches are installed in the transmission line between the reference antenna and the hybrid. One position of the diode switches is associated with the short stub of transmission line, the other position with the long stub. Successive transponder pulses are received in alternate positions of three switches. After each transponder pulse has been received, the positions of the dither switches are changed. Signals from the target on the pilot's left or from below the boresight axis are reinforced by the long stub, weakened by the short stub. Signals from the target on the pilot's right or above the boresight axis are reinforced by the short stub, weakened by the long stub. Signals along the axis are equal on both stubs but oppositely polarized; these signals average out to zero. Since target position is associated with a reinforced signal in a given position of the dither switches, dither can detect target directions.

### RANGE AND RANGE RATE ( $\overset{\circ}{R/R}$ ) METER

During the catch-up phase, the closing range rate in feet per second may be equal to or less than the square root of the numerical value of the range in feet. This means, for instance, that at 300,000 feet, the maximum closing range rate is 547 feet per second; at 30,000 feet, 173.2 feet per second; but

# PROJECT GEMINI

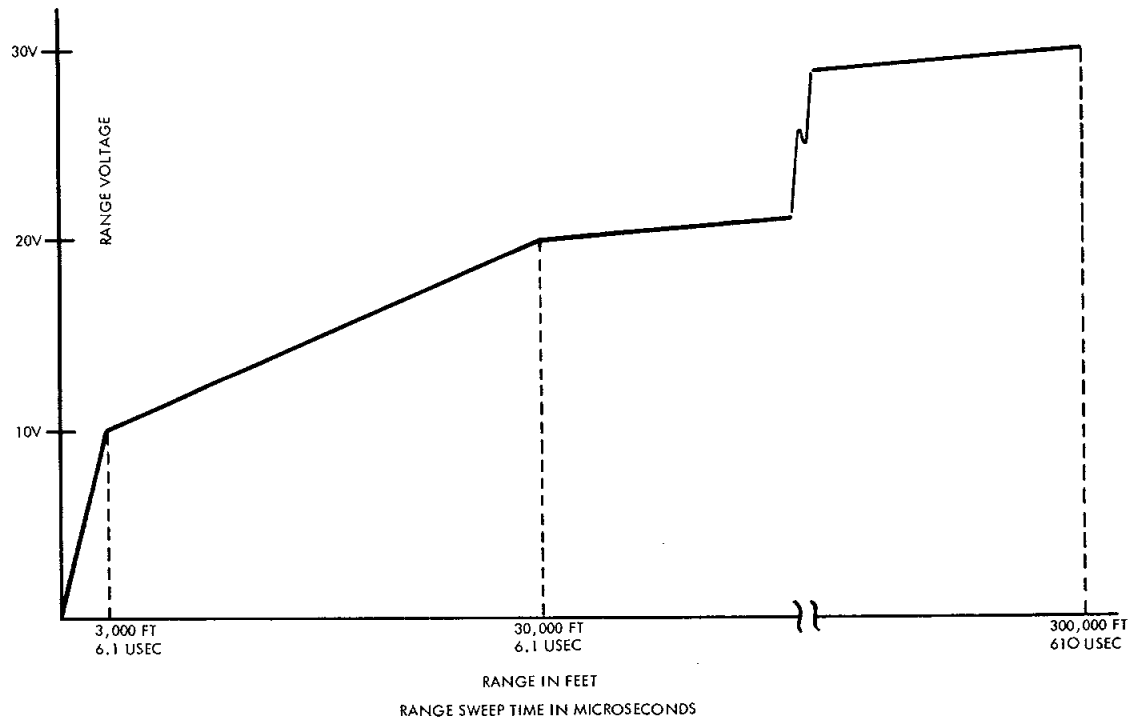
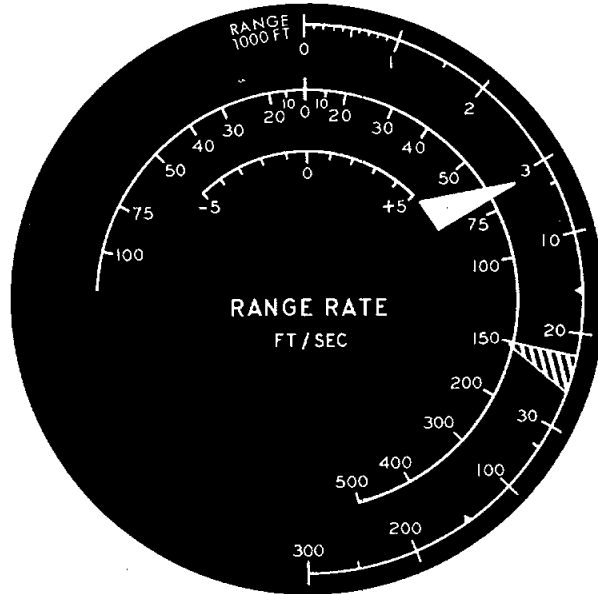
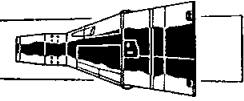

Figure 8-73 Range/Range Rate Meter and Operating Curve



# PROJECT GEMINI



at 3,000 feet, 54.7 feet per second is maximum. The range and range rate scales are arranged concentrically on the  $R/\dot{R}$  meter so that the range is on a radius directly adjacent to the maximum closing rate. (Figure 8-73) Hence, as long as the range rate needle precedes the range needle toward zero, the closing rate is not excessive. When the indicating edges of the needles coincide as the needles move toward zero, the maximum tolerable closing rate is indicated. If the range needle precedes the range rate needle toward zero, the closing rate is excessively high.

Vernier range rate is indicated in one foot-per-second increments from plus 5 to minus 5 feet per second on the scale located above center on the  $R/\dot{R}$  meter. The indicating needle for the vernier meter is usually off scale and out of sight until the spacecraft is within very near range of the target.

## RANGE SWEEP CIRCUIT

### Compression and Expansion of Meter Scales

The range and range rate meter scales are clearly nonlinear. Maximum values are compressed, minimum values are expanded. This is done because precision indications of range and range rate become far more critical as the range to target closes.

### Range Sweep Expansion and Compression

In order to make a current-operated meter indicate the range and range rate with high accuracy, a special range sweep circuit is used (Figure 8-73). The rate of voltage change with time during the first 6.1 microseconds of sweep is the most rapid. Thus the range indication from 0 to 3,000 feet is the most



## PROJECT GEMINI



expanded. During the next 54.9 microseconds of the sweep, the voltage increased with time at about 1/9th the rate of the first 6.0 microseconds. The range indication from 3,000 to 30,000 feet is expanded to a reduced extent. During the last 549 microseconds of the sweep, the voltage increases at 1/90th the rate of the first 6.1 microseconds. The range between 30,000 and 300,000 feet is compressed into a small portion of the scale. Thus the near range is 9 times more sensitive than the middle range and 90 times more sensitive than the far range.

### Range Measurement

Range is measured by sampling the sweep voltage at a time coincident with the leading edge of the transponder return pulse. The sampled voltage is stretched into a dc voltage, and applied to the range meter winding.

### Range Rate Measurement

Range rate is a function of the difference in range voltages on successive transponder pulses. This voltage difference is monitored, shaped and amplified in a circuit controlled by the same logic that changes the range sweep slope. It is applied as a dc voltage to the range rate meter coil on the far and intermediate ranges, and to the vernier range rate meter coil on the near range.

### DIGITAL RANGE COUNTER

#### Range Gated Clock Pulse Count

A high-speed digital counter counts 10-megacycle clock pulses during the range gate to generate the digital range count. (Figure 8-67 and 8-69). The clock pulses are produced by a 10 megacycle crystal-controlled oscillator in the



# PROJECT GEMINI



spacecraft radar. The range gate is started 2 microseconds after the leading edge of the interrogating pulse. This 2-microsecond delay compensates for a similar delay through the transponder. The range gate is closed by the leading edge of the transponder pulse.

## Relation of Range to Clock Time

One cycle at 10 megacycles equals 0.1 microsecond or 50 feet of radar range. Digital range supplied to the computer is the average of four successive digital counts of the range to the target. Accuracies within 50 feet or 0.1 percent of the range (whichever is larger) are obtained for ranges up to 250 nautical miles

## RADAR POWER SUPPLY

### Primary Power Requirement

Primary power to operate the rendezvous radar is obtained from the spacecraft source. Voltage from this source may vary between 22 and 30 volts dc, Noise and transients produced by various spacecraft equipment will also be present in this power. Filtering of the primary power is essential.

Electrically operated equipment in the spacecraft will reduce the voltage available from the source. The radar requires a means of maintaining its primary power voltage at a high and constant level, even though source voltage is reduced considerably.

### Input Filter and Boost Regulator

Unregulated primary power is applied to the radar power supply input. An input filter removes the noise and transients. A boost regulator uses a portion of

# PROJECT GEMINI

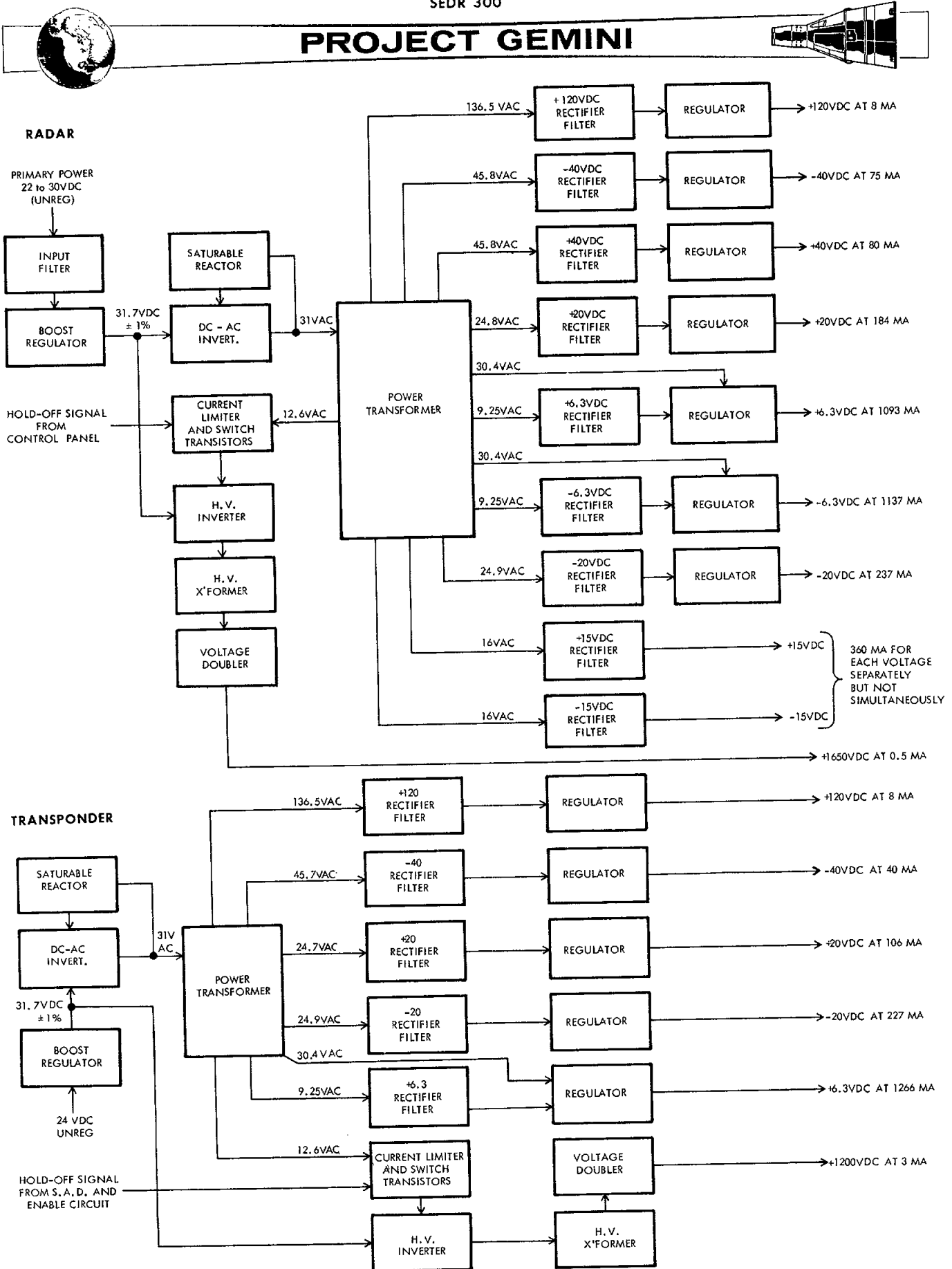

Figure 8-74 Radar and Transponder Power Supply Block Diagrams



# PROJECT GEMINI



the filtered primary power to generate a voltage to add in series with the primary voltage. The voltage generated depends on the difference between 31.7 volts dc (the boost regulator output) and the primary voltage. The boost regulator generates 1.7 volts dc and adds it in series when the primary voltage is 30 volts dc. As the primary voltage decreases, the boost regulator output increases by an equal amount (Figure 8-74).

## DC-to-AC Inverter

The dc to ac inverter changes the regulated 31.7 volts dc into 31 volts ac. The saturable reactor which is connected across the inverter stabilizes the output. The inverter energizes the power transformer. Multiple secondary windings provide all the voltages which the radar requires. Nine of the ac output voltages are rectified and filtered. Two of these, the plus and minus 15 volts dc, are used without regulation. The remaining seven rectified and filtered outputs are regulated. A short-circuit-proof circuit is built into each regulator. The regulators of the plus 120 volts dc, the plus and minus 40 volts dc, and the plus and minus 20 volts dc are each operated by the voltages they regulate. The plus and minus 6.3 volts dc do not provide a high enough voltage to operate their regulators. Therefore, additional higher voltages from the power transformer are provided to operate these regulators.

## High Voltage Power Supply

The transmitter requires plus 1650 volts dc plate voltage to produce the 1150-watt peak power interrogator pulse. A high-voltage power supply capable of generating this voltage is therefore provided. Although another winding



## PROJECT GEMINI

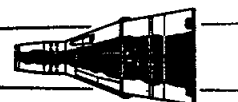

could have been added to the power transformer to supply the high ac voltage needed, transients would be applied to the common transformer each time the transmitter was fired. Consequently, a separate dc to ac inverter and high-voltage transformer were used. Only a 6.3 volt ac switch voltage for the high-voltage inverter was taken from the common transformer. In the standby state, the regulated 31.7 volts dc is applied to the high-voltage inverter. The switching voltage is applied through the current limiters to the high-voltage inverter, but is grounded out by the switching transistors which are conducting. The holdoff signal applied by the RADAR switch in the STBY position to the switching transistors causes them to conduct, preventing the high-voltage inverters from operating. When the pilot puts the radar in the search mode, he places the RADAR switch to ON. This action removes the hold off voltage, and permits the 6.3 volts ac to switch the inverter on and off. As the inverter is switched, the ac voltage is generated and applied to the high-voltage transformer. The transformer steps up this voltage and applies it to a voltage doubler. The voltage doubler rectifies and doubles the ac output of the transformer, and delivers plus 1650 volts dc to the transmitter tube plate. No high-voltage regulation is required.

### TRANSPONDER POWER SUPPLY

#### Power Supply Similarities

By comparing the block diagrams (Figure 8-74) of the radar and transponder power supplies, the similarities will be apparent. Both power supplies use a boost regulator, a dc to ac inverter, a power transformer, rectifier, filters, and regulators to provide plus 120, minus 40, plus and minus 20, and plus 6.3



# PROJECT GEMINI



volt dc outputs. The same high-voltage circuitry is also used.

## Transponder Power Supply Differences

Certain differences, of course, between the two power supplies do exist. The following are the differences: The transponder does not require the plus 40, minus 6.3, and plus and minus 15 volt dc power supplies. The current drains on individual supplies differ owing to the peculiar needs of the two units. The transponder high-voltage power supply is turned on when the sufficient amplitude detector triggers the enable delay circuit and removes the hold off voltage. Less transmitter power is used in the transponder to protect the solid-state antenna select switch (Figure 8-69).

# COMMAND LINK SYSTEM

## TABLE OF CONTENTS

TITLE	PAGE
SYSTEM DESCRIPTION. . . . .	8-275
SYSTEM OPERATION. . . . .	8-281
SYSTEM UNITS. . . . .	8-283
SUB BIT DETECTOR . . . . .	8-283
COMMAND LINK ENCODER . . . . .	8-287

# PROJECT GEMINI

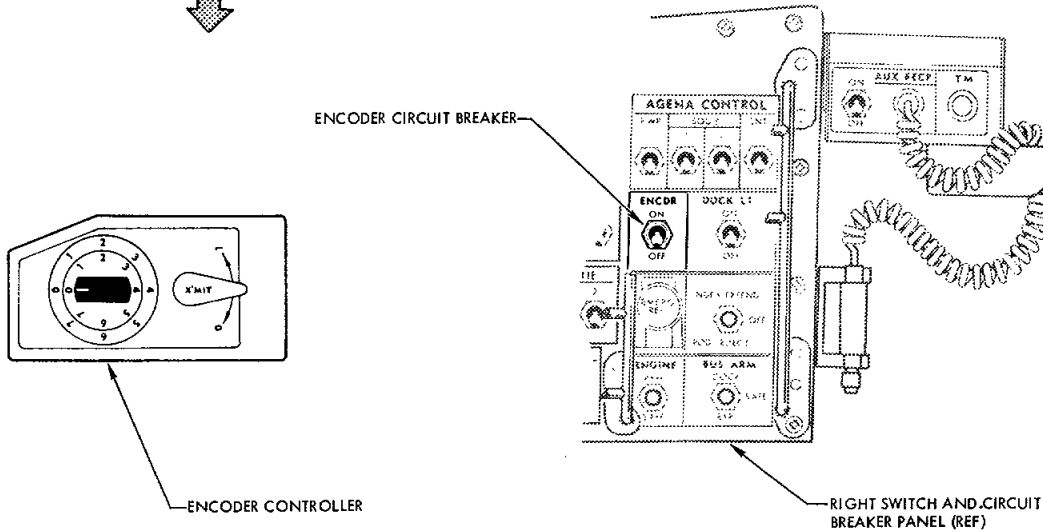
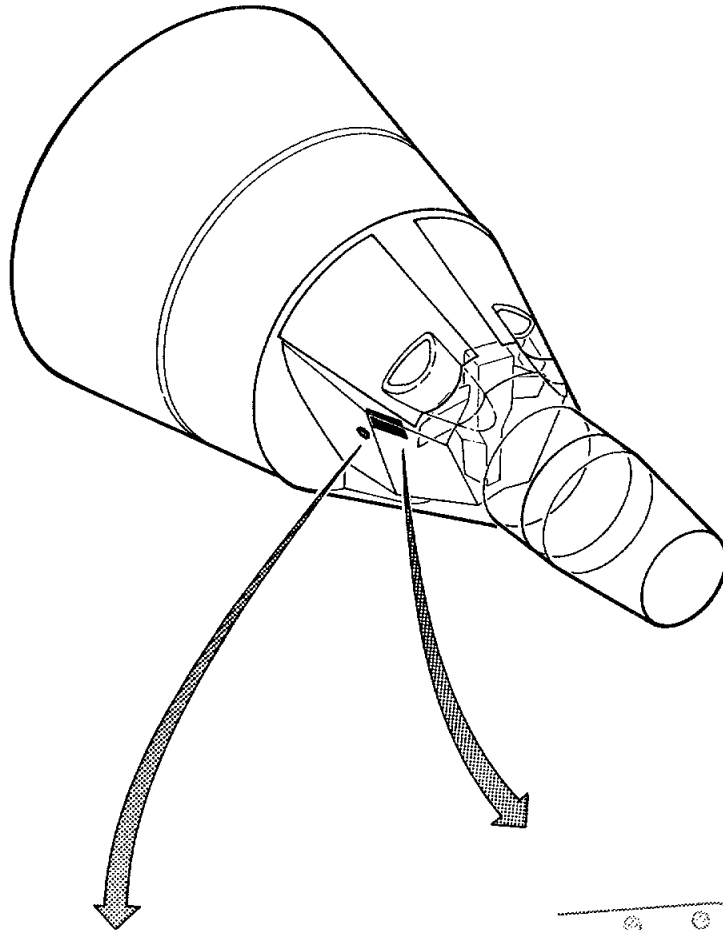

Figure 8-75 Command Link System



# PROJECT GEMINI



## COMMAND LINK SYSTEM

### SYSTEM DESCRIPTION

The Command Link System (Figure 8-75) is incorporated into the Gemini Spacecraft to allow the spacecraft pilot to control the target vehicle. Command link control is used as a means of positioning the target vehicle in the desired attitude and orbital path, of turning acquisition and approach lights on or off, and for controlling Communications and Instrumentation Systems required for ground monitoring. Using the radar rf transmission prior to docking and a hardline umbilical after docking, the command link is capable of transmitting a possible 128 command messages (Figure 8-76). Commands presently allocated and a corresponding three digit number for each of the commands are listed in Table 8-3.

Prior to docking the command link may be used any time that the rendezvous radar aboard the spacecraft is locked onto the radar transponder located in docking adapter of the target vehicle. The desired command message is inserted, by the pilot, into the encoder controller, located below and slightly aft of the right switch/circuit breaker panel. The message is then transmitted by pulse position modulation of the radar transmission through the transponder to the target vehicle programmer.

After docking, the command link messages are routed through the hardline umbilical. The method by which the pilot inserts the desired message remains unchanged. The command link also provides the pilot with the capability to unlatch from the target vehicle at the completion of the mission.

# PROJECT GEMINI

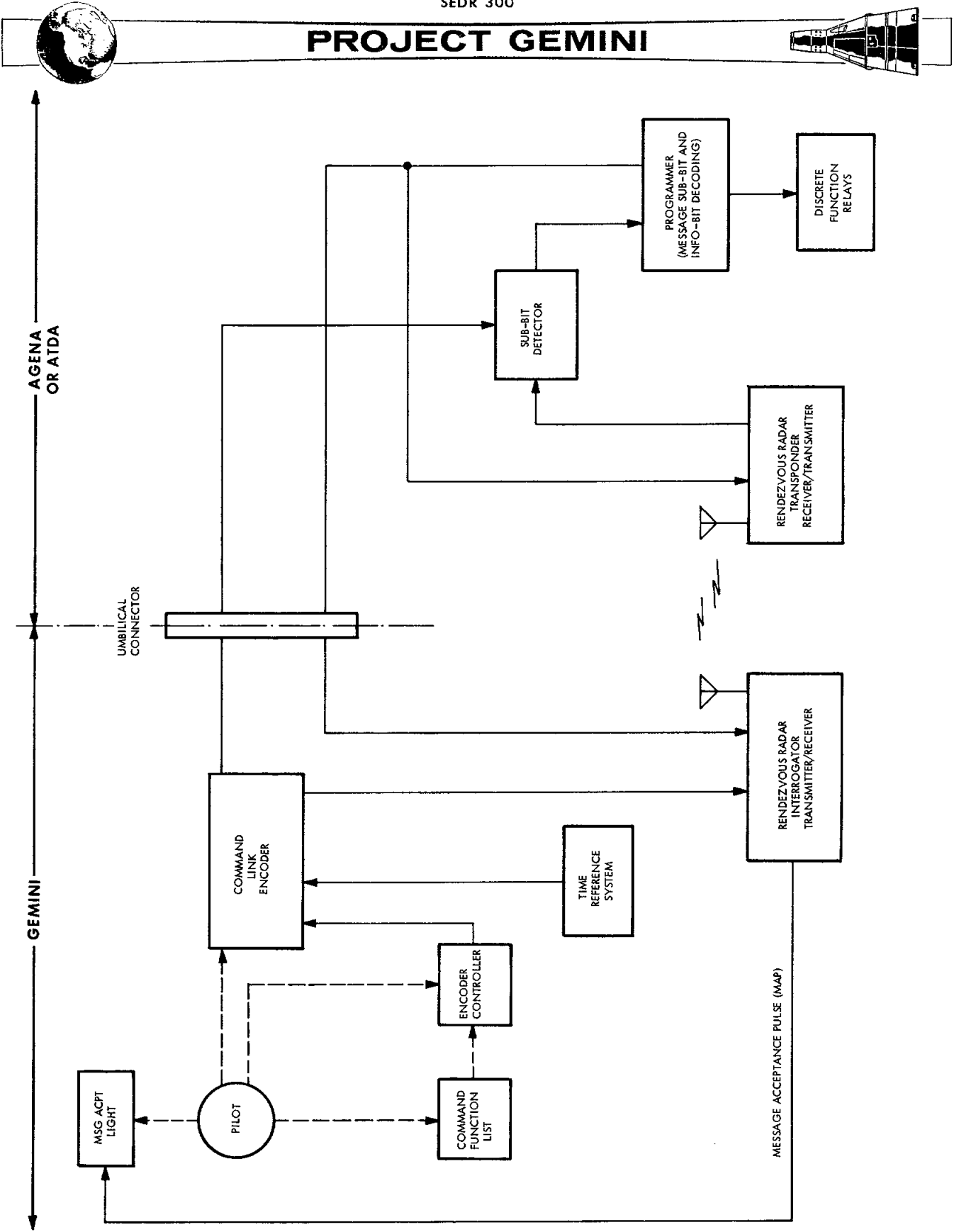

Figure 8-76 Command Link System Block Diagram



**PROJECT GEMINI**



TABLE 8-3  
COMMAND FUNCTION LIST  
AGENA TARGET VEHICLE

SPACECRAFT COMMAND NUMBER	REAL TIME COMMAND	COMMAND TITLE
001	0000001	C-Band Beacon On
010	0000010	S-Band Beacon On
011	0000011	Modulation Bus Select Normal
020	0000100	Modulation Bus Select Reverse
021	0000101	Telemetry On
030	0000110	Telemetry Off
031	0000111	Stored Data Readout
041	0001001	Record Data
050	0001010	C and S-Band Beacons Off
060	0001100	Reset Timer Reset
061	0001101	Time Word Reset
070	0001110	L-Band Beacon Off
071	0001111	L-Band Beacon On
140	0011000	Approach Lights Off
141	0011001	Approach Lights On
151	0011011	Extend Boom Antenna
160	0011100	Antenna Transfer, Ascent
161	0011101	Antenna Transfer, Orbit
200	0100000	Agena Status Display Off
201	0100001	Agena Status Display On Bright
211	0100011	Agena Status Display On Dim



**PROJECT GEMINI**



TABLE 8-3 (Continued)  
COMMAND FUNCTION LIST  
AGENA TARGET VEHICLE

SPACECRAFT COMMAND NUMBER	REAL TIME COMMAND	COMMAND TITLE
220	0100100	Adapter Unrigidize
221	0100101	Adapter Ridigize
240	0101000	Stored Program Commands Disable
241	0101001	Stored Program Commands Enable
250	0101010	Acquisition Lights Off
251	0101011	Acquisition Lights On
260	0101100	Dipole Select
270	0101110	Spiral Select
271	0101111	Power Relay Reset
300	0110000	Horizon Sensor Off
301	0110001	Horizon Sensor On
310	0110010	Roll Horizon Sensor to Yaw, Inertial Reference Package On
311	0110011	Pitch Horizon Sensor to Yaw, Inertial Reference Package On
320	0110100	Horizon Sensor to Yaw Out of Phase
321	0110101	Horizon Sensor to Yaw in Phase
340	0111000	Velocity Meter Interrogate
341	0111001	Gyrocompassing On
350	0111010	Geocentric Rate Off
351	0111011	Geocentric Rate On



**PROJECT GEMINI**



TABLE 8-3 (Continued)  
COMMAND FUNCTION LIST  
AGENA TARGET VEHICLE

SPACECRAFT COMMAND NUMBER	REAL TIME COMMAND	COMMAND TITLE
360	0111100	Geocentric Rate Reverse
361	0111101	Geocentric Rate Normal
370	0111110	Attitude Control System Pressure Low
371	0111111	Attitude Control System Pressure High
400	1000000	Attitude Control System Off
401	1000001	Attitude Control System On
410	1000010	Pitch/Yaw Minus
411	1000011	Pitch/Yaw Plus
420	1000100	Pitch/Yaw Low Rate
421	1000101	Pitch/Yaw High Rate
430	1000110	Pitch Rate Off
431	1000111	Pitch Rate On
440	1001000	Yaw Off
441	1001001	Yaw On
450	1001010	Attitude Control System Deadband Narrow
451	1001011	Attitude Control System Deadband Wide
460	1001100	Attitude Control System Gain Low
470	1001110	Attitude Control System Gain High - Undocked
471	1001111	Attitude Control System Gain High - Docked



# PROJECT GEMINI

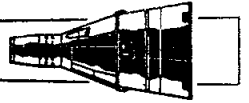

TABLE 8-3 (Continued)  
COMMAND FUNCTION LIST  
AGENA TARGET VEHICLE

SPACECRAFT COMMAND NUMBER	REAL TIME COMMAND	COMMAND TITLE
500	1010000	Primary Propulsion System Cutoff
501	1010001	Primary Propulsion System Start
520	1010100	Velocity Meter Disable
521	1010101	Velocity Meter Enable
530	1010110	Velocity Meter Load 0
531	1010111	Velocity Meter Load 1
540	1011000	Velocity Meter to Mode IV Off
541	1011001	Velocity Meter to Mode IV On
550	1011010	Secondary Propulsion System Thrust Cutoff
551	1011011	Secondary Propulsion System 16 Thrust Initiate
560	1011100	Secondary Propulsion System 200 Thrust Initiate
561	1011101	Secondary Propulsion System Ready
570	1011110	Hydraulics Gain - Undocked
571	1011111	Hydraulics Gain - Docked



# PROJECT GEMINI



## SYSTEM OPERATION

The Command Link System is energized by placing the ENCDR circuit breaker in the ON position. The ENCDR circuit breaker is located on the right switch/circuit breaker panel. The command link may now be used for the transmission of messages.

To initiate a command the Gemini pilot selects a command from a list provided. Inserts the corresponding three digit number into the encoder controller. For example; Target Docking Adapter Acquisition Lights On command number is 251. To transmit this message the Gemini pilot adjusts the encoder controller to the following positions: the outer octal dial is turned to 2, the inner octal dial is turned to 5, and the binary switch (XMIT) is positioned to 1 and held until the message cycle described in this section is completed. The only effect of the command link message transmission on the rendezvous radar is the changing of the radar pulse repetition frequency. During the message transmission the radar is switched from the internal generated pulse to the more stable Time Reference System generated 256 pulses per second.

The encoder controller output is a seven binary digit (bit) binary word, three binary bits indicating each octal number and one binary bit corresponding to the XMIT switch. The command message is added to the vehicle address, consisting of two binary bits, and the system address, consisting of three binary bits. The vehicle address used is the two binary numbers 1 1, the system address is 1 0 1. It is therefore seen that the complete command function word is as follows:



**PROJECT GEMINI**

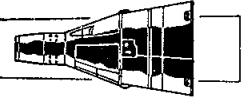

<u>VEHICLE ADDRESS</u>	<u>SYSTEM ADDRESS</u>	<u>COMMAND</u>		
		2	5	1
1 1	1 0 1	0 1 0	0 1 0	1

The positioning of the XMIT switch to either the 1 or the 0 position also initiates a one time transmission of the command.

The command link data transmission is accomplished in the following manner. The Time Reference System provides two trigger pulses to the encoder, both having a repetition rate of 256 pulses per second. One pulse will be referred to as occurring at Time Zero ( $T_0$ ) and the other at time zero plus 15.2 microseconds ( $T_0 + 15.2$ ). At the time the ENCDR ON circuit breaker is turned ON the radar commences being pulsed by the  $T_0$  pulse from the Time Reference System. The transmit command, initiated by the XMIT switch, causes the information bit to be taken, one at a time commencing with the vehicle address, and further encoded into five binary sub-bits. The encoder affects pulse position modulation of the radar interrogate transmission by allowing the  $T_0$  or  $T_0 + 15.2$  pulse to trigger the radar, indicating a 0 or a 1 respectively.

The interrogate transmission, at the repetition rate of 256 pulses per second, is received at the radar transponder. The transponder receiver video signal is applied to the sub-bit detector. The sub-bit detector contains an oscillator which is synchronized with the received interrogate 0 pulse. The oscillator provides two gates, one which occurs in synchronism with the  $T_0$  pulse and another with the  $T_0 + 15.2$  pulse. The coincidence of the received pulse with one of the above gates results in the identification of the pulse modulation. A decoded 0 generates a 25 microsecond pulse across the message complement output and a



# PROJECT GEMINI

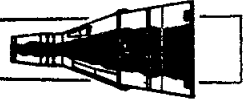

decoded 1 generates a 25 microsecond pulse across the message output. These pulses are provided to the programmer.

The programmer converts the 60 sub-bits back into the 12 information bits.

The programmer verifies that the sub-bit code is correct, that the vehicle and system address is correct, and that an acceptable message was received. If the aforementioned requirements are met the programmer will provide a message acceptance pulse to the transponder. The message acceptance pulse causes three consecutive transmissions from the transponder to shift from the normal six microsecond pulse width to ten microseconds. The radar detects the additional pulse width and causes the Message Accept (MSG ACPT) light, located on the encoder controller to illuminate for a period of 2.5 seconds.

The illumination of the MSG ACPT light indicates to the pilot that an acceptable message has been received by the programmer. At this time the pilot may release the XMIT switch.

## SYSTEM UNITS

### SUB-BIT DETECTOR

The purpose of the sub-bit detector (Figure 8-77) is the conversion of the radar transmitted pulse modulation to a pulse form indicative of the 0 and 1 sub-bit code. The sub-bit detector is also used to control the sending of the message acceptance pulse to the Gemini Spacecraft.

Prior to lock-up of the Command Link System the sub-bit detector is held in a standby state by the incorporation of a pre-acquisition loop. The variable frequency oscillator, driven at a rate of 253 cycles per second, is insensitive

# PROJECT GEMINI

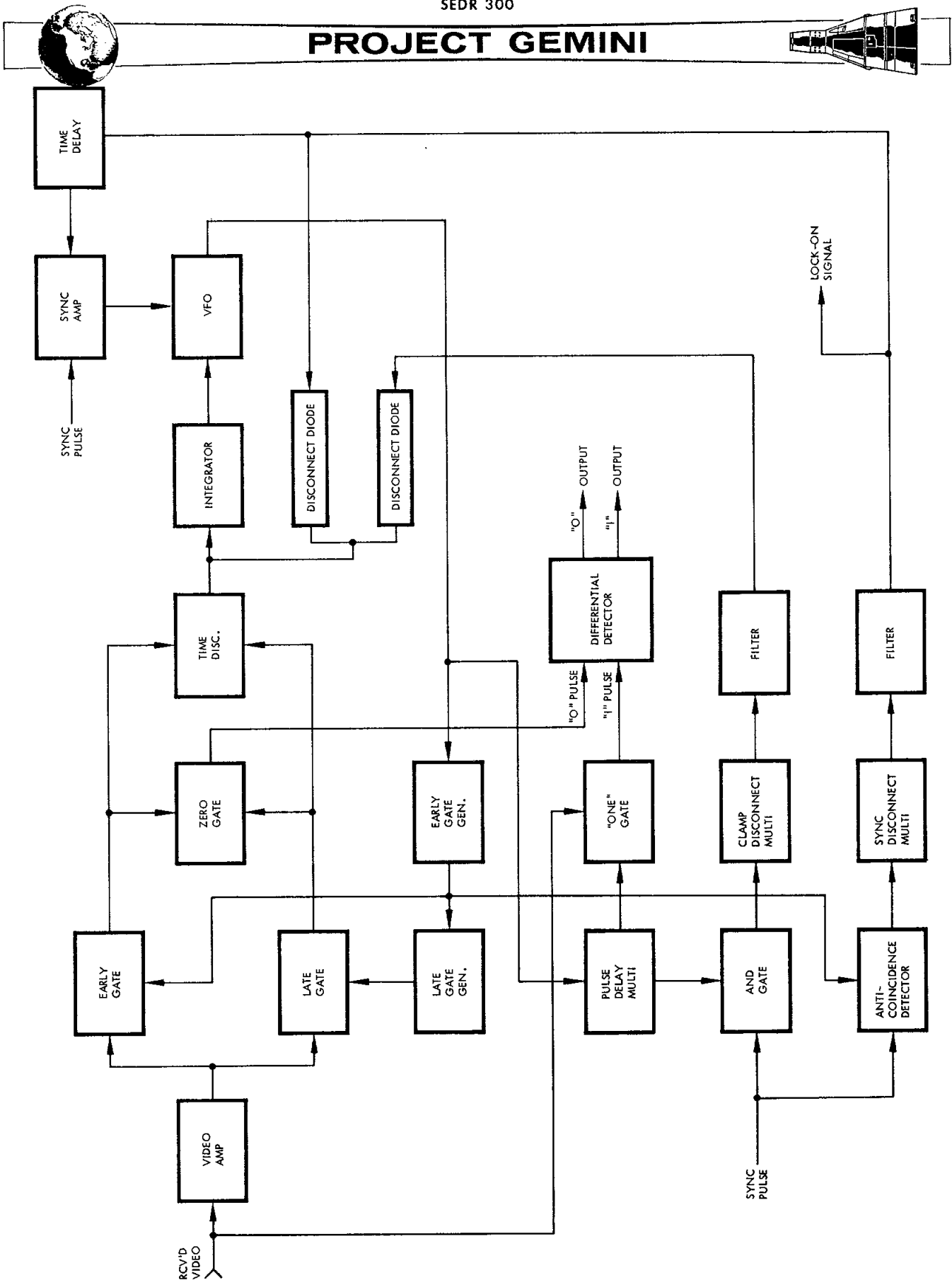
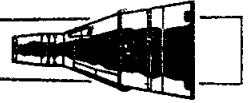

Figure 8-77 Decoder Block Diagram



# PROJECT GEMINI



to lesser frequencies. The modulated radar transmission is applied to the detector in two forms, the transponder receiver video pulse and a pulse in synchronism with the leading edge of the video. The sync pulse is applied to the oscillator thereby causing the frequency to increase to 256 cycles per second and synchronizing the early and late gates to the incoming video pulse.

The early gate and late gate, initiated by the variable frequency oscillator, are for tracking the interrogate pulse repetition frequency and detecting the transmission of the pulse corresponding to the binary sub-bit 0. The two gates are each 0.75 microseconds in width and are so related that the trailing edge of the early gate abuts on the leading edge of the late gate. The combined width of the gates is slightly more than the video pulse. The video pulse is to be centered equally between the two gates; any deviation from this condition will result in an appropriate control voltage applied to the variable frequency oscillator.

The radar modulation is determined by observing the presence of the radar transmission in either the combined early and late gate or the one gate, a 1.5 microsecond gate occurring 15.2 microseconds from the leading edge of the early gate. The continuous transmission of the sub-bit 0 enables the synchronization of the variable frequency oscillator. A slow frequency control loop provides memory so that a command message may be sent and the oscillator will maintain the correct 0 and 1 time relationship.

The sub-bit detector provides a 25 microsecond pulse over the message line to indicate a 1 and a 25 microsecond pulse over the message complement line to indicate a 0. These pulses, along, with a sync pulse which occurs for either 0 or 1, are then coupled to the computer.

# PROJECT GEMINI

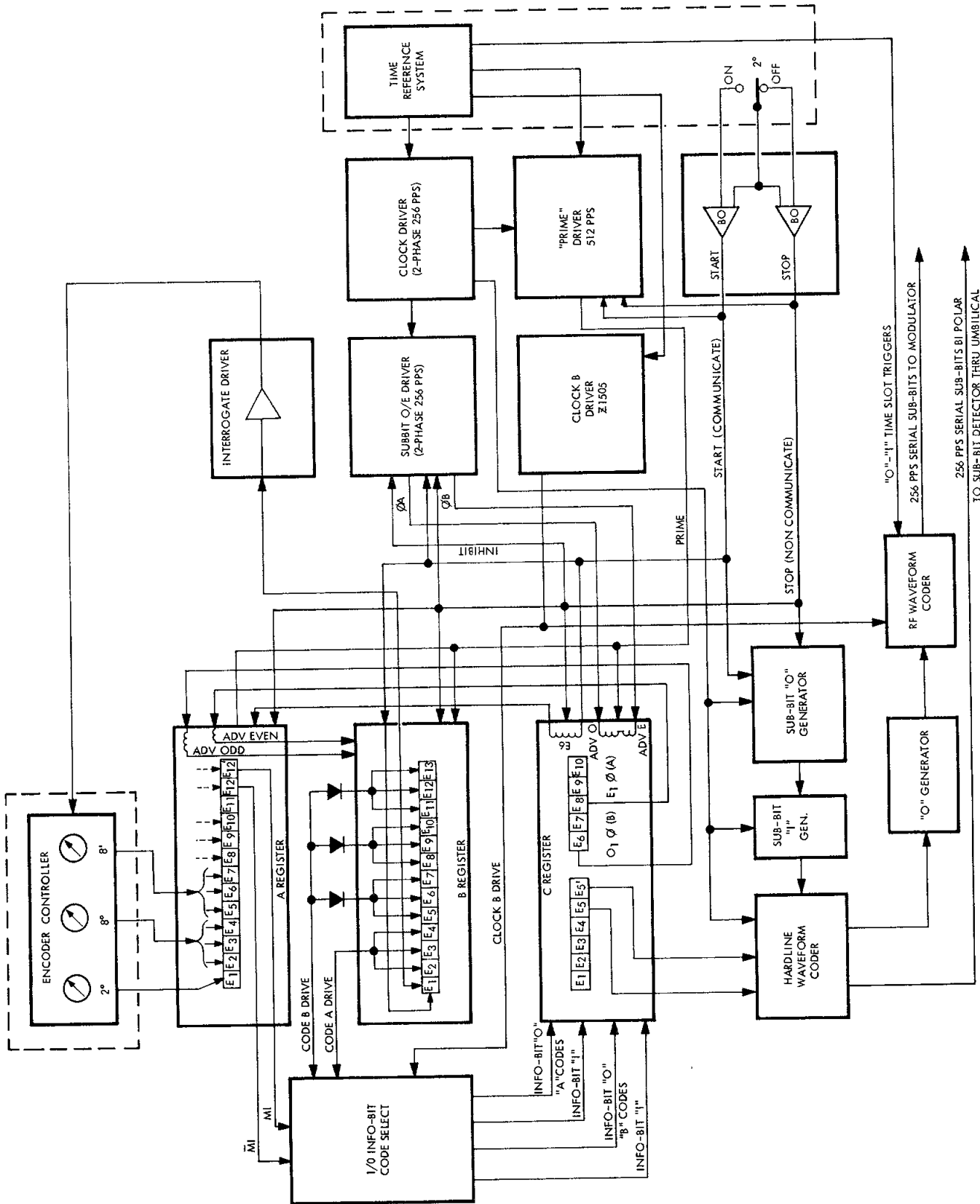

Figure 8-78 Encoder Block Diagram



# PROJECT GEMINI



## COMMAND LINK ENCODER

The command link encoder (Figure 8-78) is provided to link the commands entered into the encoder controller, by the Gemini Spacecraft pilot, to the target vehicle via two completely separate communication channels. The channel initially used is the rf link using the rendezvous radar transmission as a carrier, the link used after the docking maneuver is the hardline umbilical.

The command link message is comprised of 12 binary information bits, a vehicle address, a system address, and a command function word. The initial portion of the message, the vehicle address consisting of two information bits and the system address consisting of three information bits, are fixed in content. The command function word is made up of seven information bits, thereby allowing 128 possible commands.

The task of entering a command by manipulating seven switches, each having binary states, is undesirable from a human factors standpoint. An octal form of coding, entered by two octal switches and a binary switch, is selected for use by the spacecraft pilots. The pilot is provided with a list showing the individual commands and the corresponding three digit number. The message is entered into the encoder controller located below and slightly aft of the right switch/circuit breaker panel. The encoder switches establish a unique current routing path through a twelve bit multiaperture magnetic core shift register in the encoder for each of the 128 possible commands. The setting of the encoding switches, which represent a particular command function word, are interrogated and encoded into the infobit shift register as magnetization states of magnetic cores by means of the interrogate current pulse generated by the encoder subsequent to actuation of the XMIT switch.



# PROJECT GEMINI

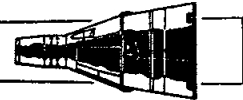

The twelve information bits are shifted sequentially in information bit message (1) and message complement (0) form from the information bit shift register and further encoded, one at a time, into another shift register in accordance with pseudo-random sub-bit code. Each is encoded into five sub-bits which are shifted sequentially in sub-bit message (1) and message complement (0) form at a 256 pulses per second rate to the hardline waveform coder. The complete message format, as a consequence of the encoding process, is a serial group of 60 sub-bits. For the hardline link the binary coded message is presented to the sub-bit detector, located in the transponder, as bipolar return-to-zero signals. For the rf link, the sub-bit message and message complement signals are pulse position modulated by the rf waveform coder in the encoder and are connected to the grid modulator of the radar. The method of pulse position modulation used will cause a normal radar pulse, indicative of the sub-bit message 0, to be transmitted in the first defined time slot while a sub-bit message 1 will cause transmission of the rf pulse delayed 15.2 microseconds from the normal, or 0 position.

# RENDEZVOUS EVALUATION POD

## TABLE OF CONTENTS

TITLE	PAGE
SYSTEM DESCRIPTION. . . . .	8-291
SYSTEM OPERATION. . . . .	8-291
SYSTEM UNITS. . . . .	8-294
TRANSPONDER. . . . .	8-294
ANTENNA SYSTEM . . . . .	8-294
FLASHING LIGHT BEACONS . . . . .	8-295
SQUIB BATTERIES. . . . .	8-296
RENDEZVOUS POD COVER . . . . .	8-298

# PROJECT GEMINI

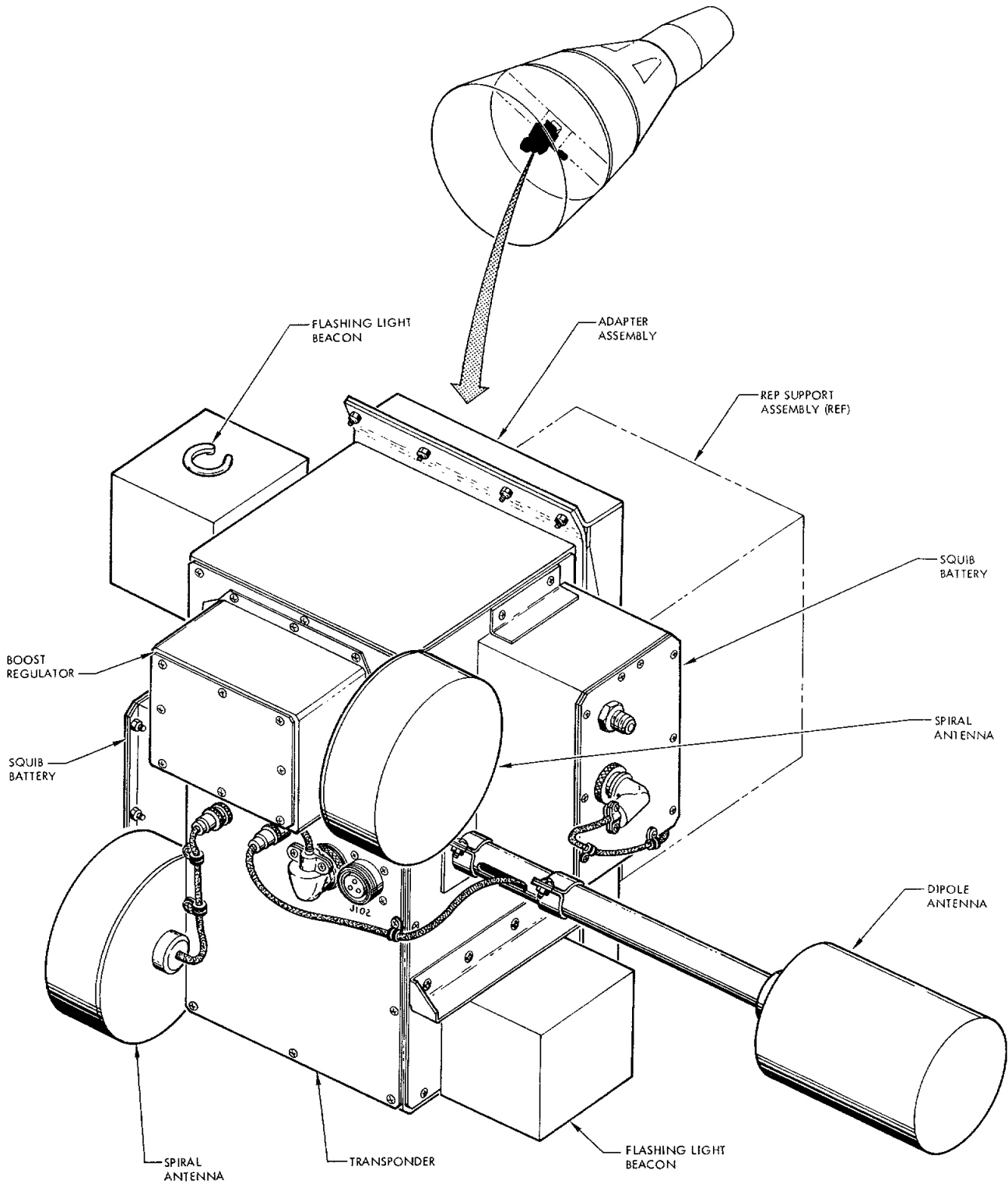
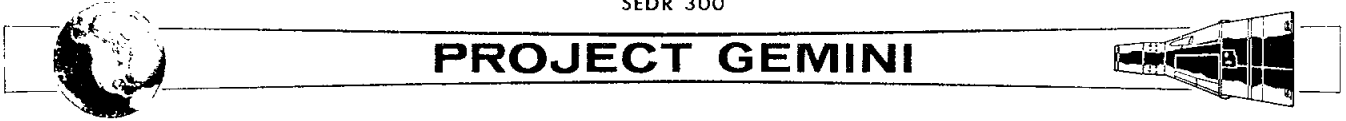
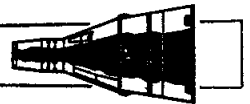

Figure 8-79 Rendezvous Evaluation Pod

8-290



# PROJECT GEMINI



## RENDEZVOUS EVALUATION POD

### SYSTEM DESCRIPTION

The Rendezvous Evaluation Pod (REP) (Figure 8-79) is an assembly used during Gemini Spacecraft mission number five to simulate the Agena Target Vehicle. The REP consists of a transponder, two antenna systems, two flashing light beacons, and two squib batteries. The transponder is nearly identical to the transponder to be installed in the Agena. The flashing light beacons, which emit  $80 \pm 1$  flashes per minute, are visible for approximately twenty miles. These beacons are to enable the crew of the Gemini to gain tracking experience by visually observing the REP in space. Observations are at measured distances from the spacecraft against both earth and sky background. This experience is used in determining the placement and intensity required for the Agena acquisition lights. The REP also provides a means of studying the man/equipment interface problems which might be encountered during an actual rendezvous mission with the Agena. The REP was installed in the center of the equipment adapter section of the spacecraft (Figure 8-79). Thermal protection for the REP prior to ejection is provided by the rendezvous pod cover. The REP is ejected into orbit by a pyrotechnic charge, after the spacecraft has been inserted into a satisfactory orbit.

### SYSTEM OPERATION

During the first 65 minutes after lift-off, the REP remains stationary in the equipment adapter of the spacecraft (Figure 8-80). The REP is ejected from the spacecraft near the end of the first orbit. Other activities related to the REP occur primarily during the second orbit.

# PROJECT GEMINI

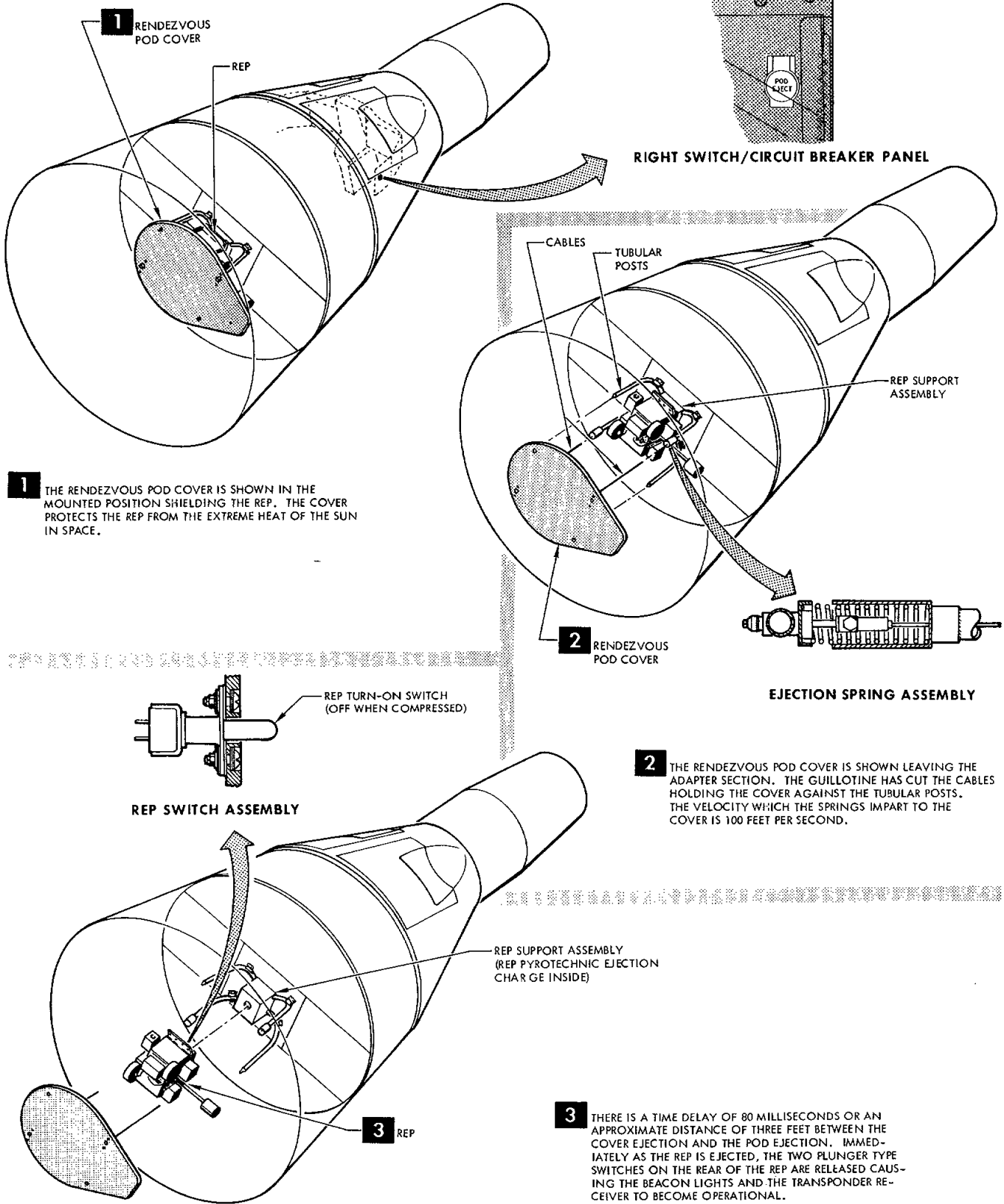

**1** THE RENDEZVOUS POD COVER IS SHOWN IN THE MOUNTED POSITION SHIELDING THE REP. THE COVER PROTECTS THE REP FROM THE EXTREME HEAT OF THE SUN IN SPACE.

**2** THE RENDEZVOUS POD COVER IS SHOWN LEAVING THE ADAPTER SECTION. THE GUILLOTINE HAS CUT THE CABLES HOLDING THE COVER AGAINST THE TUBULAR POSTS. THE VELOCITY WHICH THE SPRINGS IMPART TO THE COVER IS 100 FEET PER SECOND.

**3** THERE IS A TIME DELAY OF 80 MILLISECONDS OR AN APPROXIMATE DISTANCE OF THREE FEET BETWEEN THE COVER EJECTION AND THE POD EJECTION. IMMEDIATELY AS THE REP IS EJECTED, THE TWO PLUNGER TYPE SWITCHES ON THE REAR OF THE REP ARE RELEASED CAUSING THE BEACON LIGHTS AND THE TRANSPONDER RECEIVER TO BECOME OPERATIONAL.

Figure 8-80 Mounting and Ejection of Cover and Rendezvous Evaluation Pod



# PROJECT GEMINI



The REP has two spring-loaded, plunger-type switches (Figure 8-80) which control the battery power to the beacon lights and the transponder. Prior to ejection these normally closed switches are held depressed (open) so that power is conserved. The pilot will eject the REP approximately fifteen minutes prior to the first perigee. The spacecraft will yaw left  $90^{\circ}$  and the POD EJECT switch located on the right switch/circuit breaker panel (Figure 8-80) will be depressed. Pushing the POD EJECT switch activates two pyrotechnic charges (Figure 8-80). One charge drives a guillotine type cable cutter which severs the two cables shown in Figure 8-80. The cables, when released, allow the two compressed springs to expand, thereby propelling the rendezvous pod cover from the rear of the spacecraft. The relative ejection velocity of the cover is 100 feet per second. The other charge, initiated after an 80 millisecond time delay, propels the REP from the spacecraft with the relative velocity of 3.4 feet per second. The cover will not interfere with the ejection of the REP since the ejection velocity of the cover is much greater than and is prior to the ejection of the REP.

Since the REP will be orbiting outside the earth's atmosphere, it will experience extreme hot and cold temperature conditions. Therefore, a slow rate of rotation or tumble of the REP is desirable to allow uniform heating and cooling throughout the mission. If the retrograde thrust were applied to the exact center of gravity of the REP, no tumbling would result. Since a very minute error is anticipated in locating the exact center of gravity, a slow tumble within the required limits is expected. For successful operation, the rate of tumbling of the REP will be between one revolution per minute and one revolution per hour.



# PROJECT GEMINI



Immediately upon ejection the compressed, spring-loaded, plunger-type switches are released causing the transponder receiver and the two flashing light beacons to become operational. It is estimated that the flashing lights on the REP at 20 nautical miles are equivalent to the intensity of a third magnitude star. Thus, a range of 30-35 nautical miles between the REP and the spacecraft is desired to assure exceeding the visible limit of the REP lights. The REP and the spacecraft trajectories will be designed so that the crew can make visual observations of the REP up to the maximum observational distance in both daylight and darkness. The ejection of the REP and the maneuvering of the spacecraft is performed over ground tracking stations to provide ground monitoring capability.

## SYSTEM UNITS

### TRANSPONDER

The transponder of the REP (Figure 8-79) is nearly identical to the transponder of the Agena Target Vehicle. The transponder, 10 by 10 by 20 inches, is the largest component of the REP. For this reason, the transponder serves as the basic component to which all other components are attached. For a detailed discussion of the operation of the transponder, refer to the Rendezvous Radar System portion of this section.

### ANTENNA SYSTEM

The REP radar antenna systems (Figure 8-79) consist of two circularly polarized double-spiral antennas and one dipole antenna array. The REP antennas are the same type and size as the antennas used on the Agena, however, there are several slight differences in the manner in which the antennas are mounted. The spiral antennas of the REP extend outward approximately two inches from the case of the



# PROJECT GEMINI



transponder. In comparison, the spiral antennas of the Agena are mounted flush with the outer surface of the Agena. The dipole antenna of the REP is mounted on the end of a two-foot long fixed boom, whereas the dipole antenna of the Agena is mounted on an electrically operated, retractable boom. The electrical operations of the two antenna systems are the same. All antennas have the capability of transmitting and receiving. Refer to the Rendezvous Radar System in this manual for a detailed discussion of the antenna system operation.

## FLASHING LIGHT BEACONS

The REP has two toroid-shaped, xenon-filled, 25-watt beacon lights. These lights are the same type lights as the 100 candlepower Agena acquisition lights which are used on the Agena target vehicle. The lights are located on opposite sides of the REP so that at least one light is visible to the crew from any direction. The beacon lights assist the crew in maneuvering the spacecraft relative to the REP.

The flashing of the lights is regulated by a resistor-capacitor circuit located in each mounting case. The charging circuit is designed so that both lights operate simultaneously and assume the flashing rate of the light having the higher rate of flash. This rate can be manually adjusted within a range of 75 to 90 flashes per minute however the optimum rate is  $80 \pm 1$  flashes per minute. The lights have a life expectancy of 25,000 flashes, or approximately 5 hours. This is more than sufficient time, since the REP will be used for approximately one and one half hours.



# PROJECT GEMINI

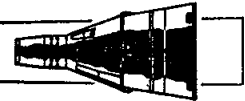

Each beacon light has a thermal bonding strap attached. The thermal bonding strap is a  $\frac{1}{4}$  inch thick strap of laminated copper which is used to help dissipate the heat generated by the light. The lights are connected through two redundant plunger-type switches to a 24 volt silver-zinc battery. The flashing circuit uses a dc to dc converter to increase the battery voltage to the 2500 volts required to flash the xenon filled lamps. The electrical schematic diagram of the lighting system is shown in Figure 8-81.

## SQUIB BATTERIES

The REP utilizes two low impedance, 24-volt, silver-zinc squib batteries. The batteries are the same type of squib battery used in the spacecraft. Figure 8-79 shows one of the squib batteries attached to the case of the transponder. The other battery is on the other side of the REP and cannot be identified in the illustration. The squib batteries serve as the power source for the transponder and the two beacon lights. The transponder and the beacon lights are each served from a separate squib battery and operate independently of one another.

During spacecraft mission number 5 the REP will be required to function for only a very small time, approximately one orbit or 90 minutes. Therefore, it is not necessary that the batteries possess an exceptionally long life. The life of the lights is the limiting factor. Due to the short usage period, the size and weight of the batteries can be held to a minimum. For a detailed discussion of the internal structure and operation of the squib battery, refer to the section entitled Electrical Power System .

The battery supplying power to the transponder is augmented by a boost regulator. The operating level of the transponder is 28.3 volts and the rated voltage

# PROJECT GEMINI

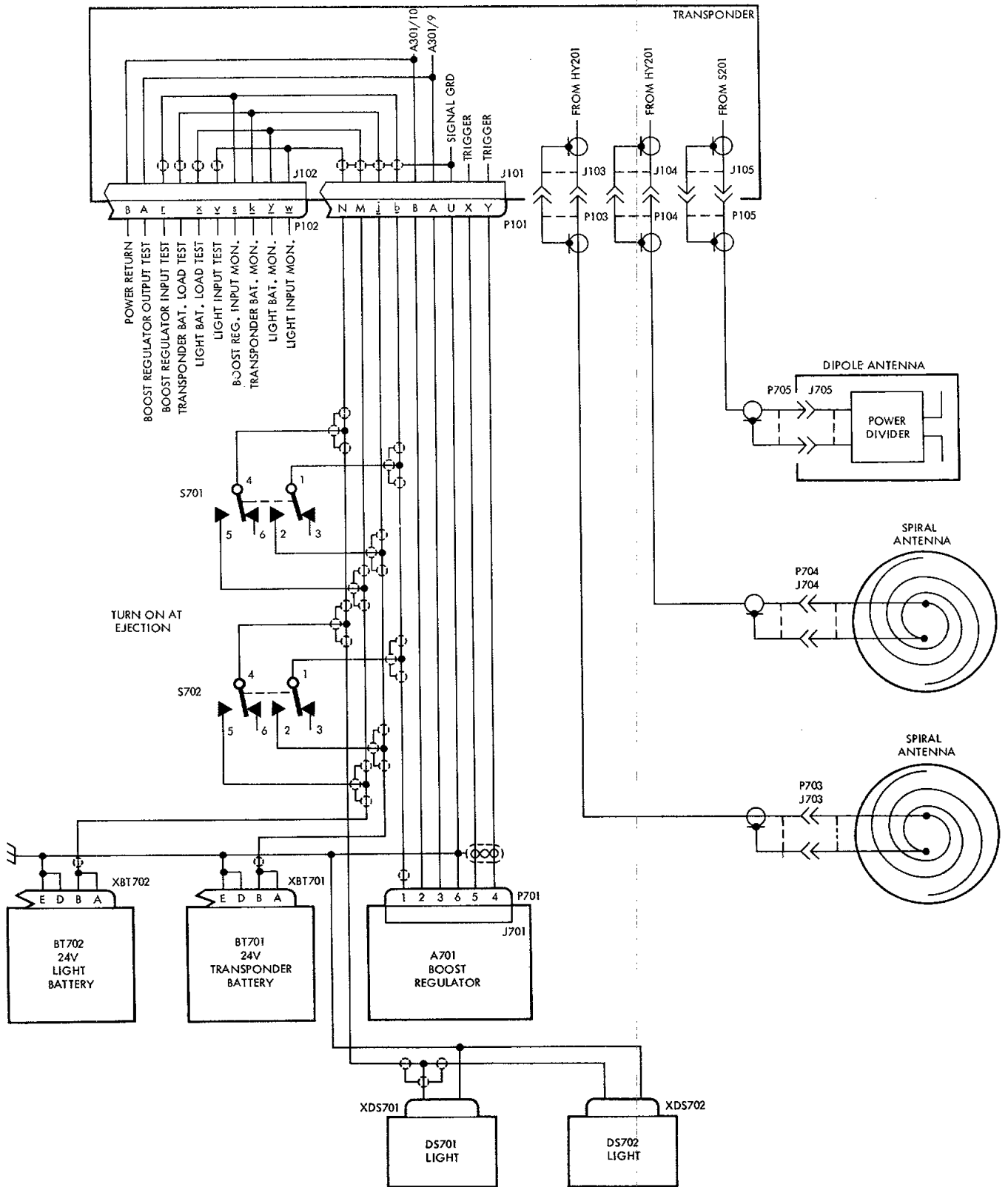

Figure 8-81 Rendezvous Evaluation Pod Schematic Diagram



## PROJECT GEMINI



of the squib battery is only 24 volts, therefore it is necessary that a boost regulator be incorporated into the system. The purpose of the boost regulator is to increase the transponder input voltage to and maintain it at the required 28.3 volt operating level.

As the power is consumed and the voltage of the squib battery decreases, the boost regulator compensates for the decrease by adding a variable voltage in series with the squib battery. The additional voltage of the boost regulator varies so that there is a constant 28.3 volts input to the transponder at all times. Refer to the schematic diagram of Figure 8-81 for further information on how the batteries of the REP are employed.

### RENDEZVOUS POD COVER

The rendezvous pod cover (Figure 8-80) is an oval, plane structure which is located directly behind the REP in the equipment-adaptor section of the spacecraft. The cover is like an umbrella which serves to protect the REP from the intense heat of the sun's rays in space. The cover is made of a tubular metal frame over which a thin fiberglass cloth is stretched. The outer face of the cover has a .00035 inch thick silvered surface. This silvered surface reflects the sun's rays, thereby ensuring that the temperature of the REP remains within the required limits.

Four tubular posts, which extend past the REP, are provided to support the cover. Two of the posts diagonally located terminate in guide pins. These guide pins are used to properly align the cover. The other two posts terminate



# PROJECT GEMINI



in sockets which house the spring ejection assembly. The cover is held in place by two cables which pass through the springs, sockets, and tubes. Both cables pass through a pyrotechnic guillotine and are anchored to the REP support assembly. The other end of each cable is attached to the rendezvous pod cover by a screw and a nut. This screw and nut serves as a turnbuckle and is used to apply tension to the cable, causing the spring to be compressed.

Ejection of the cover is initiated in the same manner as the ejection of the REP. When the pilot pushes the POD EJECT switch, a pyrotechnic charge activates the guillotine-type cable cutter which severs the two cables. Cutting the cables allows the two compressed springs to expand, thus imparting a relative velocity to the cover of 100 feet per second. The cables remain with the cover after ejection.

# TIME REFERENCE SYSTEM

## TABLE OF CONTENTS

TITLE	PAGE
SYSTEM DESCRIPTION . . . . .	8-303
SYSTEM OPERATION . . . . .	8-304
ELECTRONIC TIMER . . . . .	8-306
TIME CORRELATION BUFFER . . . . .	8-324
MISSION ELAPSED TIME DIGITAL CLOCK . . . . .	8-326
EVENT TIMER . . . . .	8-333
ACCUTRON CLOCK . . . . .	8-339
MECHANICAL CLOCK . . . . .	8-340

# PROJECT GEMINI

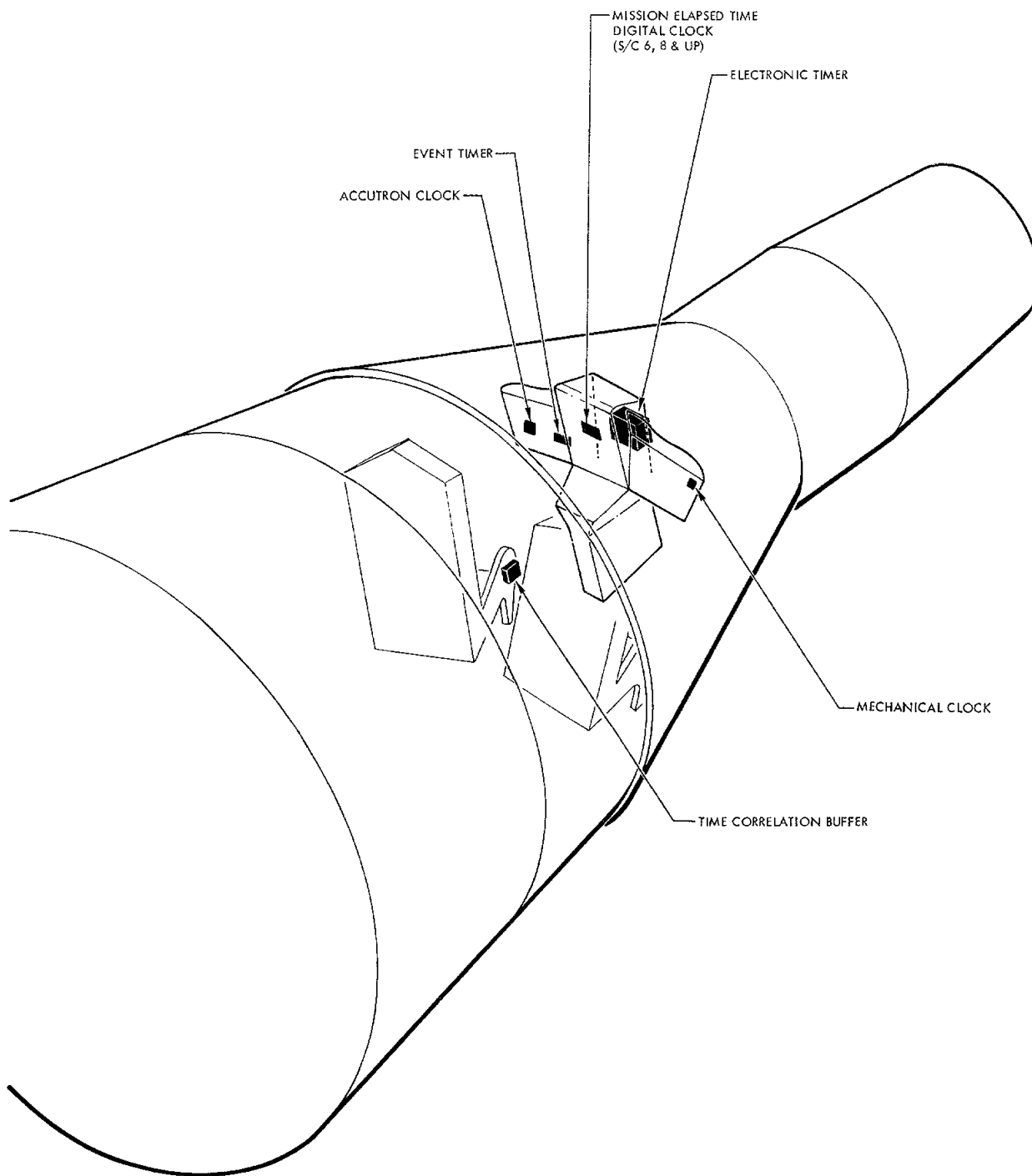
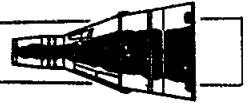

Figure 8-82 Time Reference System Equipment Locations



# PROJECT GEMINI



## TIME REFERENCE SYSTEM

### SYSTEM DESCRIPTION

The Time Reference System (TRS) (Figure 8-82) provides the facilities for performing all timing functions aboard the spacecraft. The system is comprised of an electronic timer, a time correlation buffer, a mission elapsed time digital clock, an event timer, an Accutron clock and a mechanical clock. The event timer, mission elapsed time digital clock, Accutron clock and mechanical clock are all mounted on the spacecraft instrument panels. The electronic timer is located in the area behind the center instrument panel and the time correlation buffer is located in back of the pilot's seat.

The electronic timer provides (1) an accurate countdown of Time-To-Go to retro-fire (TTG to  $T_R$ ) and Time-To-Go to equipment reset (TTG to  $T_X$ ), (2) time correlation for the PCM data system (Instrumentation) and the bio-med tape recorders, and (3) a record of Elapsed Time (ET) from lift-off.

The Time Correlation Buffer (TCB), conditions certain output signals from the electronic timer, making them compatible with bio-med and voice tape recorders. Provision is included to supply buffered signals for Department of Defense (DOD) experiments if required.

The mission elapsed time digital clock (on spacecraft 6 through 12) provides a digital indication of elapsed time from lift-off. The digital clock counts pulses from the electronic timer and is therefore started and stopped by operation of the electronic timer.



# PROJECT GEMINI

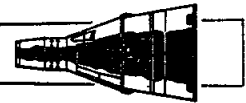

The event timer provides the facilities for timing various short-term functions aboard the spacecraft. It is also started at lift-off to provide the pilots with a visual display of ET during the ascent phase of the mission. In case the electronic timer should fail, the event timer may serve as a back-up method of timing out  $T_R$ .

The Accutron clock provides an indication of Greenwich Mean Time (GMT) for the command pilot. The clock is powered by an internal battery and is independent of external power or signals.

The mechanical clock provides the pilot with an indication of GMT and the calendar date. In addition, it has a stopwatch capability. The stopwatch provides an emergency method of performing the functions of the event timer.

## SYSTEM OPERATION

Four components of the Time Reference System (electronic timer, event timer, Accutron clock and mechanical clock) function independently of each other. The two remaining components (mission elapsed time digital clock and time correlation buffer) are dependent on output signals from the electronic timer. A functional diagram of the Time Reference System is provided in Figure 8-83.

The electronic timer, mission elapsed time digital clock, Accutron clock and the time-of-day portion of the mechanical clock operate continuously, during the spacecraft mission. The mechanical clock and Accutron clock are started during the pre-launch period. The electronic timer starts operating upon receipt of a remote start signal from the Sequential System at the time of lift-off.

# PROJECT GEMINI

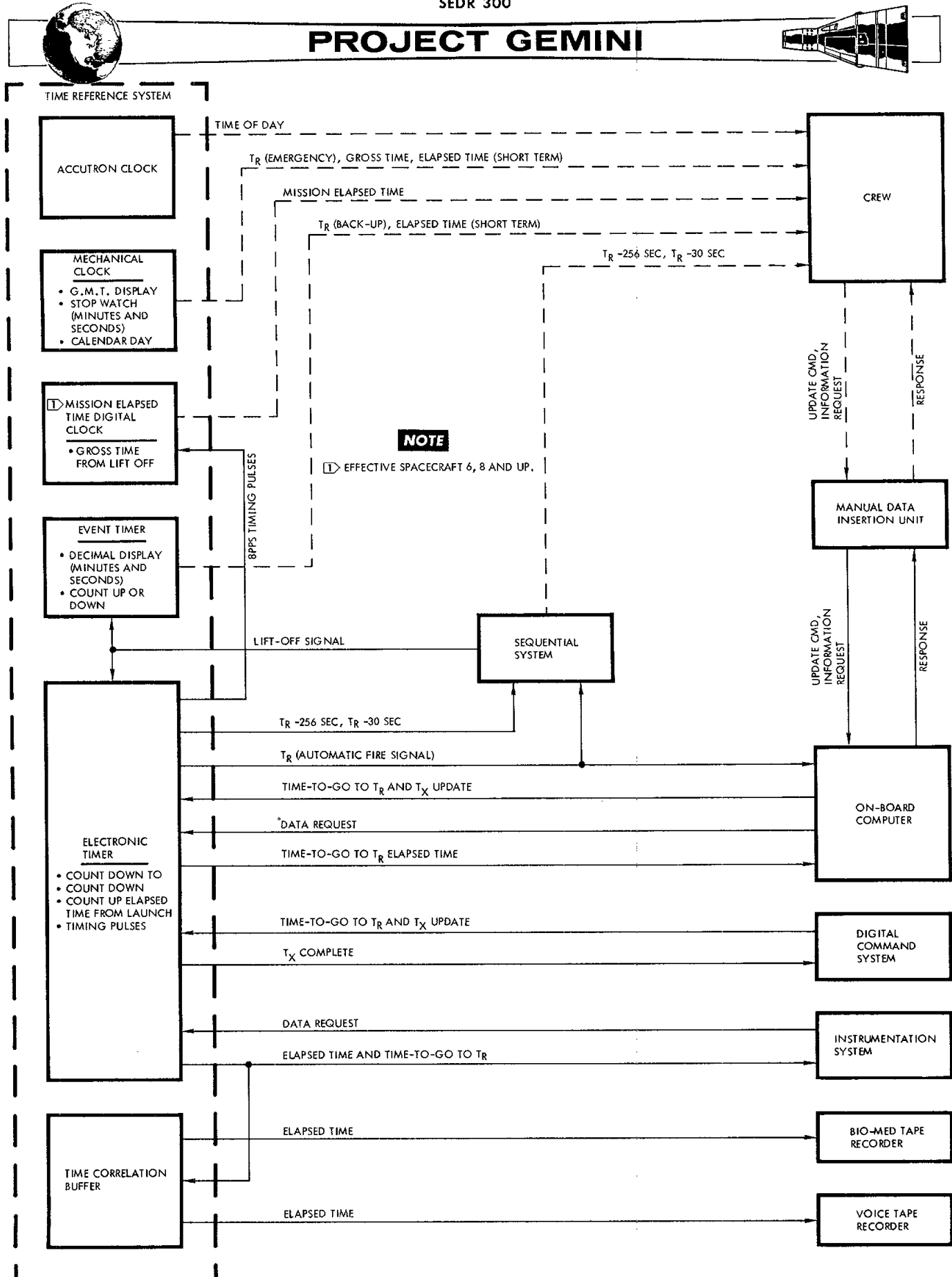
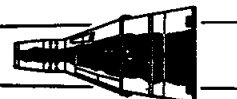

Figure 8-83 Time Reference System Functional Diagram



# PROJECT GEMINI



If the lift-off signal is not received from the Sequential System, the electronic timer can be started by actuation of the START-UP switch on the event timer. The mission elapsed time digital clock and time correlation buffer start operating upon receipt of output signals from the electronic timer.

During the mission, the event timer, Accutron clock and the stopwatch portion of the mechanical clock can be started and stopped, manually, at the discretion of the crew. At lift-off, however, the event timer is started by a remote signal from the Sequential System.

## ELECTRONIC TIMER

### General

At the time of lift-off, the electronic timer begins its processes of counting up elapsed time and counting down TTG to  $T_R$  and TTG to  $T_X$ . ET is counted up from zero to a maximum of approximately 24 days. The retrofire and equipment reset functions are counted down to zero from certain values of time which are written into the timer prior to lift-off. The timer is capable of counting TTG to  $T_R$  from a maximum of 24 days and to equipment reset from a maximum of two hours.

The TTG to  $T_R$  data contained by the timer may be updated at any time during the mission by insertion of new data. Updating may be accomplished either by a ground station, through the Digital Command System (DCS), or by the crew, via the Manual Data Insertion Unit (MDIU) and the digital computer. To prevent inadvertent, premature countdown of  $T_R$  as a result of equipment failure or personnel error during update, the timer will not accept any new time-to-go of less than 128 seconds duration. Upon receipt of new data of less than the inhibit time mentioned above, the timer will cause itself to be loaded with a time in excess of two weeks.



# PROJECT GEMINI



The TTG to  $T_x$  function of the timer serves to reset certain equipment which operates while the spacecraft is passing over a ground station equipped with telemetry. As the spacecraft comes within range, the ground station inserts, via the DCS, a TTG to  $T_x$  in the timer. Then, as the spacecraft moves out of the range of the ground station, the TTG to  $T_x$  reaches zero, and the equipment is automatically reset. If the ground station is unable to insert the time data, it may be done by the crew, using the MDIU and digital computer.

Information from the electronic timer is not continuously displayed; however, confirmation of satisfactory operation may be made by the readout of  $T_R$  data through use of the digital computer MDIU display readout capability.

## **NOTE**

The mission elapsed time digital clock counts pulses from the electronic timer and, assuming no loss of pulses, will indicate the elapsed time recorded in the electronic timer. The digital clock does not, however, read out the elapsed time word from the electronic timer.

### Construction

The electronic timer (Figure 8-84) is approximately 6 inches x 8 3/4 inches x 5 1/2 inches and weighs about ten pounds. It has two external connectors for interface with its associated systems. The enclosure for the unit is sealed to keep out moisture but is not pressurized. The timer utilizes a modular construction, containing eight modules which are wired directly into the enclosure. The modules are:

- (1) crystal oscillator,
- (2) timing assembly,
- (3) register control assembly,

# PROJECT GEMINI

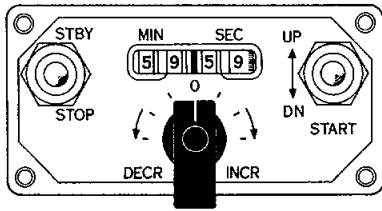

EVENT TIMER

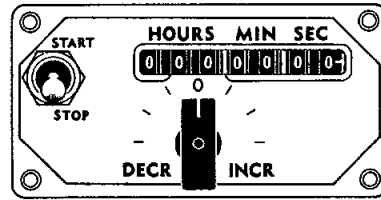

MISSION ELAPSED TIME DIGITAL CLOCK

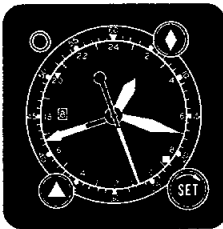

MECHANICAL CLOCK

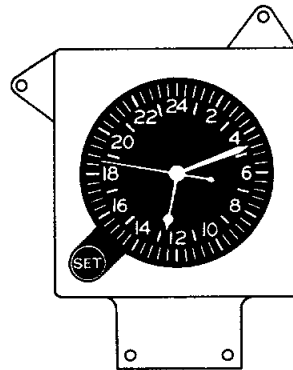

ACCUTRON CLOCK

**NOTE**

EFFECTIVE SPACECRAFT 6, 8 AND UP.

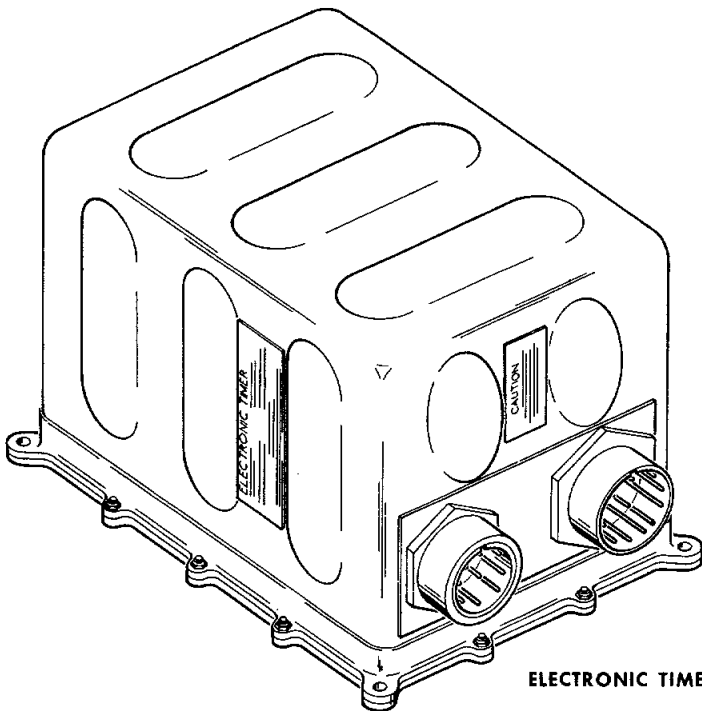

ELECTRONIC TIMER

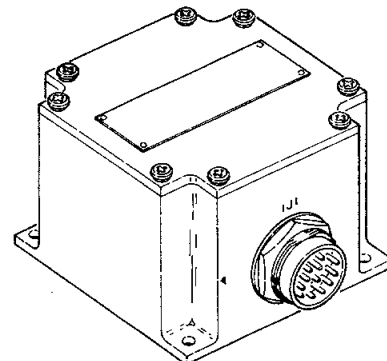

TIME CORRELATION BUFFER

Figure 8-84 Time Reference System Components



# PROJECT GEMINI

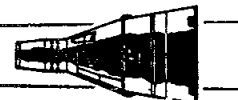

(4) memory control assembly, (5) memory assembly, (6) driver assembly, (7) relay assembly, and (8) power supply. Printer circuit boards and solid-state components are used in all modules except the crystal oscillator.

## Operation

The electronic timer is basically an electronic binary counter. It performs the counting operation for each of its functions (ET, TTG to  $T_X$ , and TTG to  $T_X$ ) by an add/subtract program which is repeated every  $1/8$  seconds. (Refer to Figure 8-85). In each repetition of the counting operation, a binary word, representing ET or a TTG, is modified to represent a new amount of time. Magnetic core storage registers are used to store or remember the binary words between counting cycles. A storage register is provided for each of the three timer functions and another is provided for use as a buffer register for data transfer between the timer and the digital computer.

A crystal controlled oscillator is used as a frequency standard for developing the timing pulses necessary for the operation of the timer. The type of oscillator provides the high degrees of accuracy required for the timer whose operations take place in very small fractions of a second. The oscillator is coupled to a series of toggle flip flops whose outputs provide the actual timing pulses for the timer operation.

The electronic timer utilizes a 32-word time program. That is, each  $1/8$  second of time is further divided into 32-word times. Each word time is divided into 32 bit times, and each bit time is divided into 32 S pulses times. S pulses are the shortest pulses used in the timer operation and are 3.8 microseconds long. One bit time is equal to 122 microseconds and one word time 3.9 milliseconds.

# PROJECT GEMINI

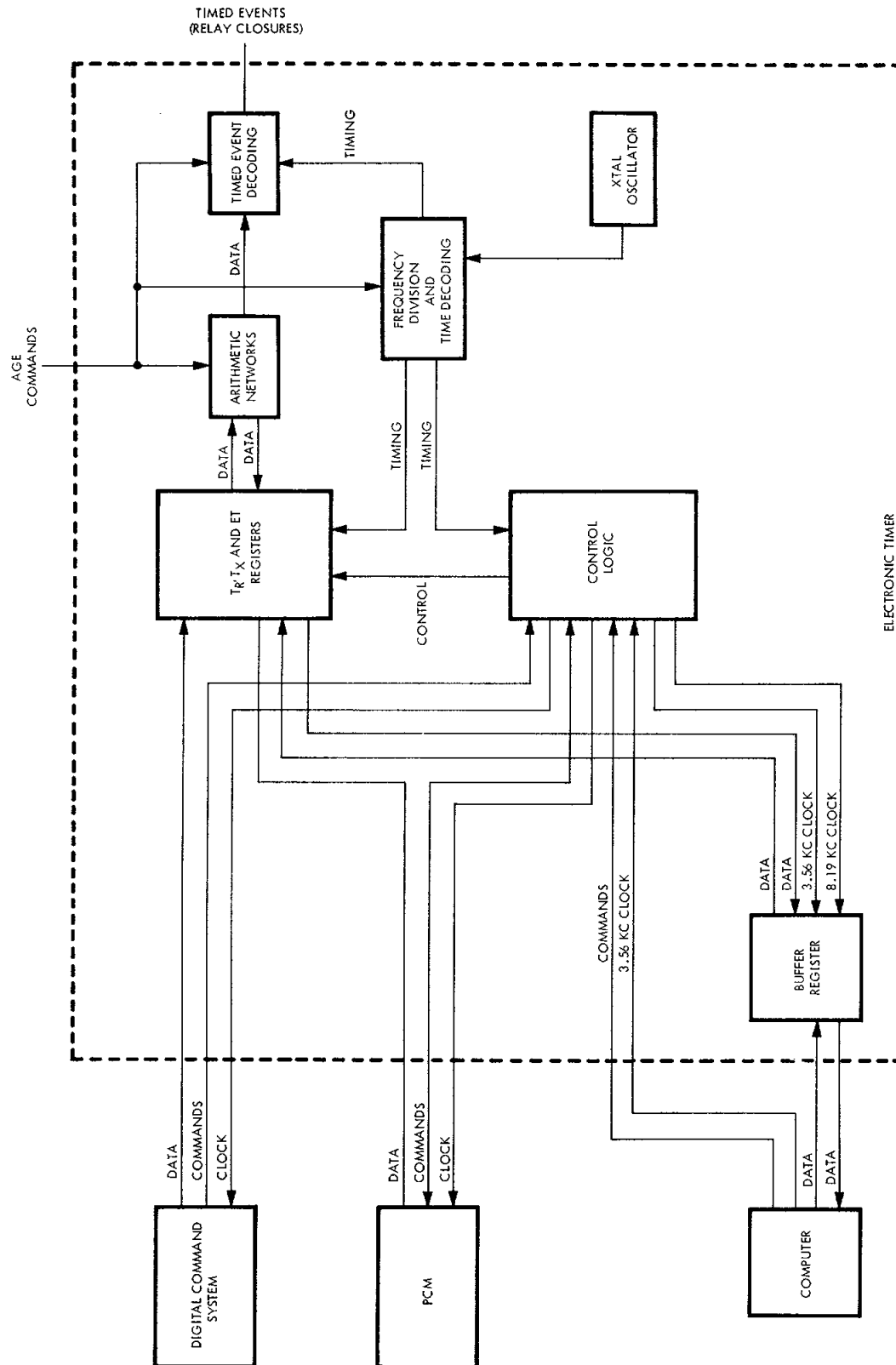

Figure 8-85 Electronic Timer Functional Block Diagram



## PROJECT GEMINI



It is pulses of these durations, and their multiples, which are produced by the toggle flip flops in the timing module.

### Timer Start Circuit

Timer operation is initiated when a 28 vdc start signal is received from either the spacecraft Sequential System or the event timer. The signal from the Sequential System is transmitted to the electronic timer, automatically, at liftoff; the one from the event timer is generated when the UP/DN toggle switch on the face of the unit is placed in the UP position. Receipt of a signal from either source causes the set side of the clock-start relay to be actuated. Until lift-off, the relay is held in the reset position by a clock-hold signal from the AGE via the spacecraft umbilical. This is done to assure that the timer will not be started prematurely and will be at zero at the time of lift-off. Actuation of the clock-start relay causes a positive control signal to be applied to a gate in the timing module. This gate allows the output of the crystal controlled oscillator to be coupled to the countdown flip flops.

### Countdown and Time Decoding

The countdown and time decoding operations take place primarily in the timing module. When timer operation is initiated, the 1.048576 megacycle output of the crystal-controlled oscillator is coupled to the first of a series of 17 toggle flip flops (Refer to Figure 8-86). Twelve of the flip flops are contained in the timing module and five in the register control module. The flip flops form a frequency dividing network, each stage of which produces one square wave output pulse for every two input pulses. The output frequency of the final stage in the series is eight pulses per second.

# PROJECT GEMINI

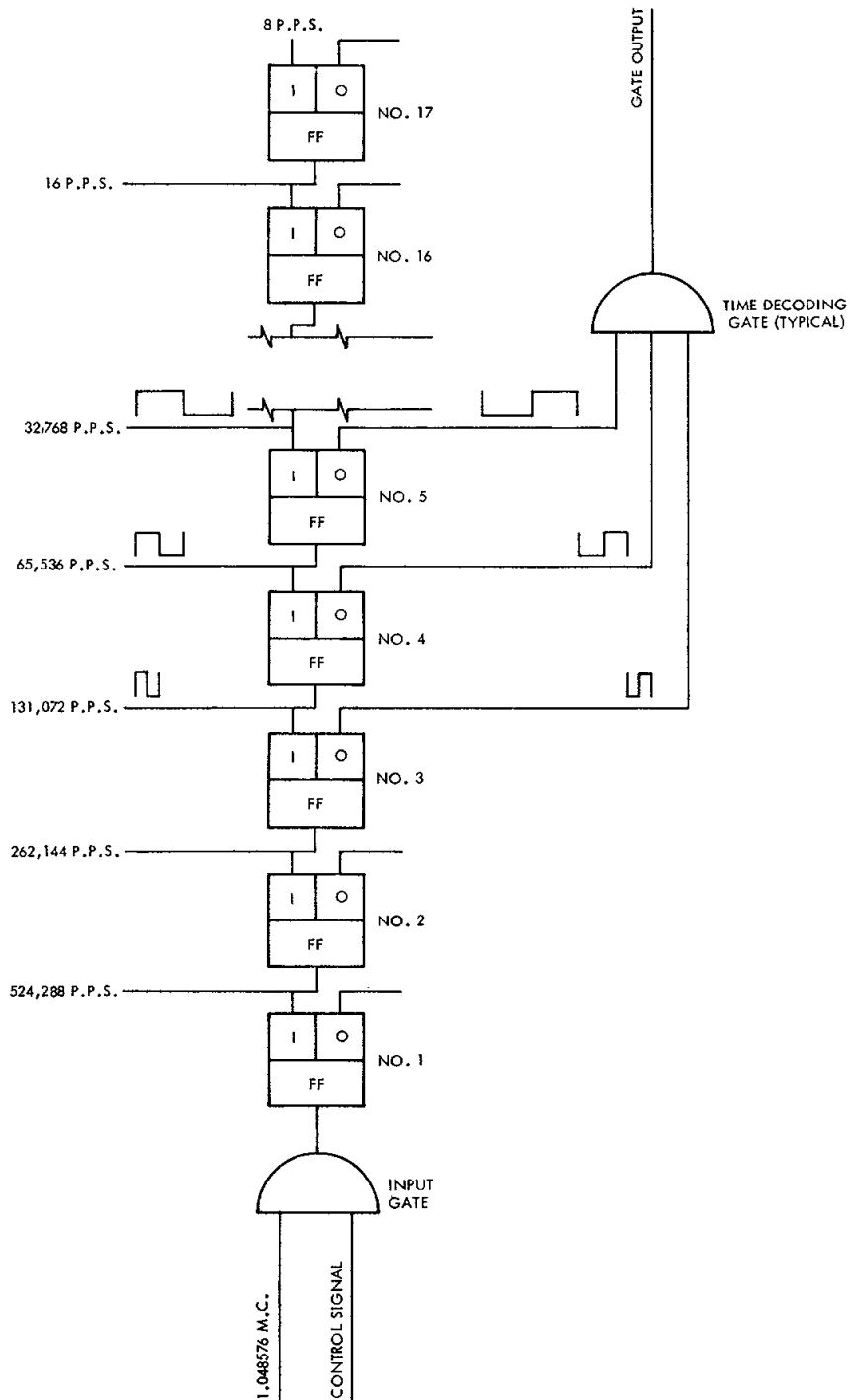
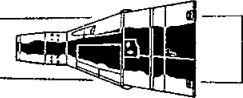

Figure 8-86 Schematic Diagram, Frequency Division & Time Decoding



# PROJECT GEMINI



Outputs of all but the first two stages of the countdown circuitry are utilized to develop the timing pulses necessary for timer operations. Output pulses from either the 1 or the 0 side of an individual flip flop may be used; however, the polarity of the pulses from one side will be  $180^\circ$  out of phase with those from the other side. Pulses from the flip flop outputs are supplied, in certain combinations, to gate circuits in the time decoding section. Each gate circuit receives several input pulse trains and produces output pulses which are usable for the timer circuitry (Refer to Figure 8-87a). Basically, a gate will produce output pulses which will have the pulse width of the narrowest input pulses and the frequency of the input pulse train with the widest pulses. If the polarity of one input is reversed, the time at which the output pulse occurs, will change (Refer to Figure 8-87b).

## Operational Control

Two complete modules are required to encompass all of the circuitry necessary to perform the control functions in the electronic timer. The register control module primarily controls the transfer of data into and out of the timer. The memory control module directly controls the operations of the magnetic storage registers in the memory module.

The register control module supplies the control signals which are required to perform the operations directly associated with the transfer of time data. It utilizes the various command and clock signals from the other spacecraft systems to produce its control signals. The control signals are then supplied to the appropriate circuitry to: (1) receive a new binary data word (as in the updating process), (2) initiate the shifting operations of the proper storage registers to write in or read out the desired time data ( $ET$ ,  $T_X$ , or  $T_X$ ), and (3) supply



## PROJECT GEMINI



data, read out of the storage registers, to the proper timer output terminal(s) to be transferred to the system requesting it.

The memory control module directly controls the operation of the magnetic storage registers and performs the arithmetic computations of the counting process. Inputs from the timing and register control modules are utilized to develop the shift and transfer output pulses for shifting data words into and out of the storage registers. These pulses are developed separately for each register.

Both control modules are made up of rather complex and overlapping networks of logic circuitry. The memory control module also employs shift current generators and transfer switches, as output stages, to develop the required power capabilities.

### Storage Register Operation

The magnetic storage register to ET,  $T_X$ , and  $T_X$  are used to store or remember binary words of time data. These data words may be shifted out of their respective registers, as required, for the counting operations and for transfer to other spacecraft systems. The transfer of data into and out of a storage register is accomplished, serially, with the Least Significant Bit (LSB) first.

A storage register is comprised of a series of magnetic memory cores, each of which is capable of storing one binary bit of time data. This capability is based upon the characteristic of a magnetic core to saturate in one of two directions when a current pulse is applied to one of its windings (Figure 8-88). Saturation in one direction represents a binary 1 and indicates the presence of a data bit. Saturation in the other direction represents a binary 0 and indicates the absence of data bit. The storage registers for ET and TIG to  $T_R$  each contain  $2^4$  magnetic

 **PROJECT GEMINI** 

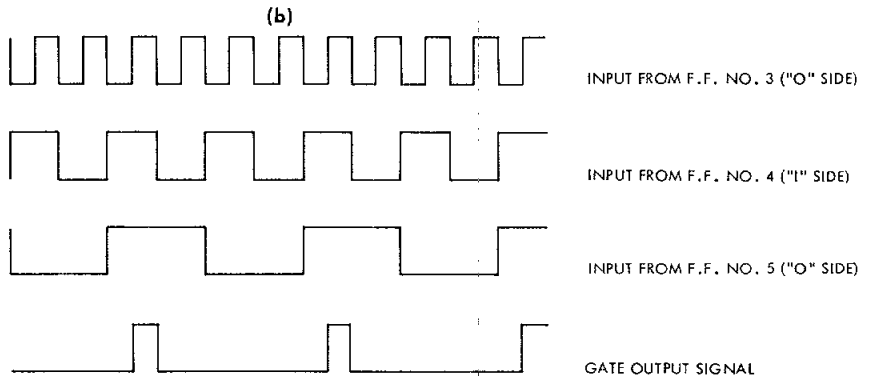
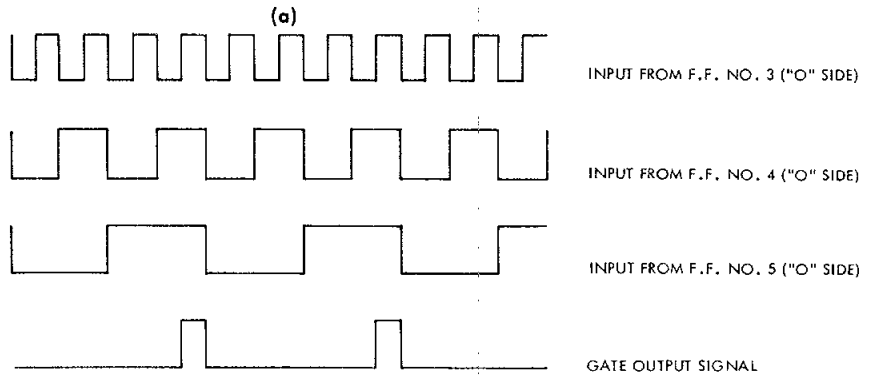

Figure 8-87 Time Decoding Gate Inputs and Outputs (Typical)

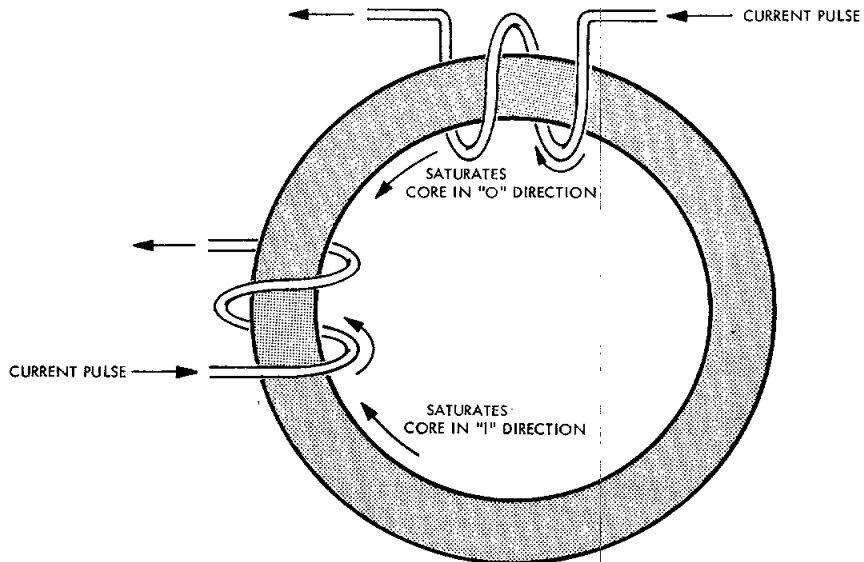
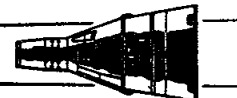

Figure 8-88 Magnetic Core Operation



# PROJECT GEMINI



cores and the register for TTG to  $T_X$  contains 16. Therefore, a binary word for ET or  $T_R$  consists of 24 bits, while a word for  $T_X$  consists of 16 bits.

The use of the binary system for time representation permits the storage of data which can represent an amount of time as small as  $1/8$  second and as large as 24 days. Each data bit in a binary data word represents one individual increment of time. In looking at the flow diagram in Figure 8-89a, the 24 sections of the storage register represent its 24 individual cores. The data bit which represents the smallest time increment ( $1/8$  second) is stored in core number 24. It is referred to as the LSB in the data word. Core number 23, then would store the next bit (representing  $1/4$  of a second) of the data word. The sequence continues, with core number 22 representing  $1/2$  second, back through core number 1 with each successive core representing a time increment twice that of the preceding one. By adding together the increments of time represented by all of the cores, the total time capacity of the register can be determined. Thus, it is found that the ET and  $T_R$  registers have capacities of approximately 24 days and the  $T_X$  register, approximately two hours. Conversion of a data word to its representative may be accomplished by totaling the increments of time represented by the bit positions of the word where binary ones are present. For the data word shown in Figure 8-89b the representative time is  $583 \frac{3}{8}$  seconds.

The process of shifting a data word into or out of a storage register is controlled by the occurrence of the shift and transfer pulses and by the condition of a control gate preceding each register and its write-in amplifier. The shift and transfer pulses from the control section are supplied to a storage register whenever a data word is to be written in or read out. These pulses occur once each bit time for a duration of one word time. The actual flow of data into a



# PROJECT GEMINI

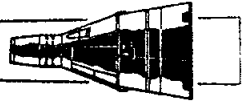

storage register is controlled by a logic gate preceeding the write-in amplifier for each register (Figure 8-90). The count enable input of the gate will have a continuously positive voltage applied after lift-off has occurred. The write-in pulse input will have a positive pulse applied for 7.6 microseconds during each bit time (122 microseconds). These two inputs control the gate. The result is that a positive data pulse may pass through the gate only during a 7.6 microsecond period during each bit time.

When a binary data word is to be written into a storage register, its individual bits appear at the input of core number 1 as a series of current pulses. When the first current pulse (representing 1/8 second) of the word flows through the input winding of core number 1, the core is saturated in the binary 1 direction. It remains in this condition until a current pulse flows through the shift winding of the core. The shift pulse causes the flux of the core to collapse and reform, switching the core back to the 0 condition. When this occurs, a voltage is developed across the output winding of the core and the temporary storage capacitor is charged through the winding from the diode end. When the shift pulse decays and a ground potential is placed on the transfer line, the capacitor discharges through the input winding of the next core, setting it to the binary 1 condition. Whenever a bit position of the incoming data word does not contain a pulse, core number 1 is not switched to 1. As a result, its shift pulse causes no change of flux; no voltage is developed across the output and the capacitor is not charged or discharged. Hence, the next core is not set to the 1 condition. Because the shift pulses are applied to all the cores in a register, simultaneously, it is assured that each one is set to the 0 condition before the transfer pulse (also applied to all cores, simultaneously) allows the storage capacitors to discharge. When

PROJECT GEMINI

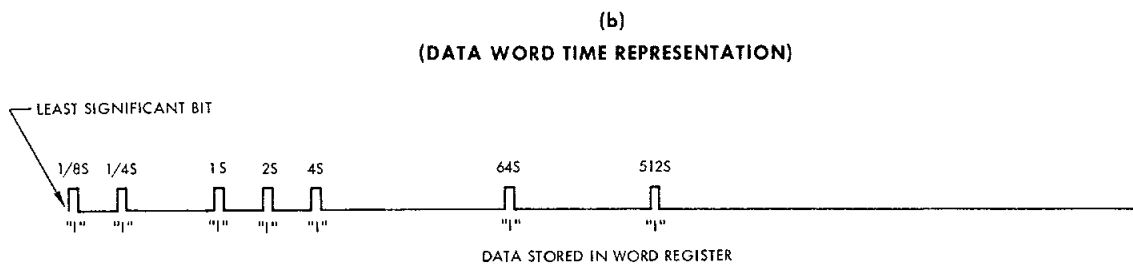
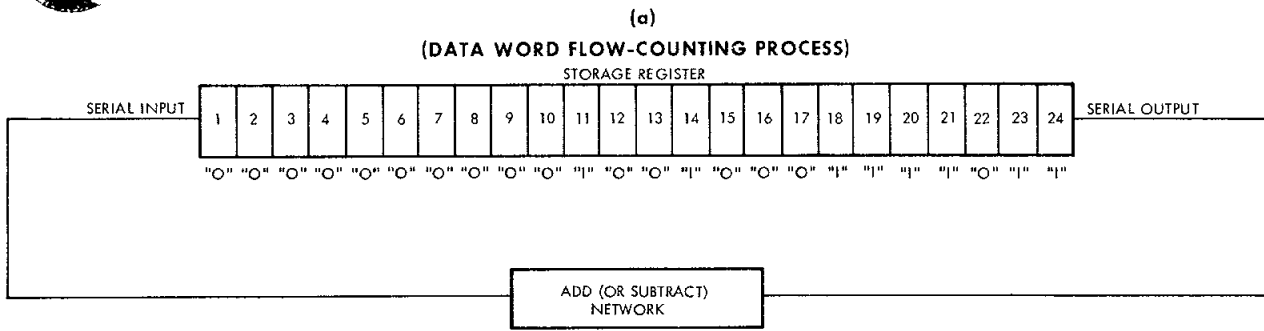
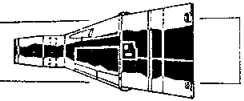

Figure 8-89 Time Data Word Flow & Representation

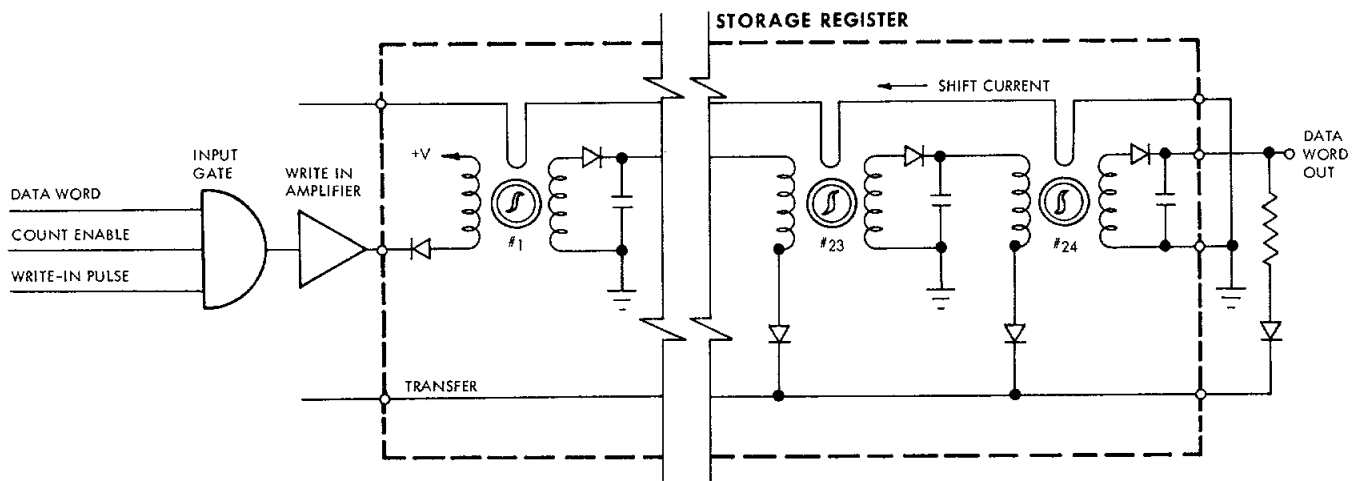

Figure 8-90 Schematic Diagram-Storage Register



# PROJECT GEMINI



a complete word has been written into the register, the cores which are in the binary 1 condition contain the binary data bits.

Reading a data word out of a storage register involves basically the same processes as writing one in.

The data bits shift from left to right, with the bit in core number 24 leaving the register first. An additional bit is shifted out of the register with each repetition of the shifting process.

## Counting Operations

The counting operation for each of the timer functions consists of reading a binary data word out of a storage register, cycling it through an arithmetic network, and writing it back into the register. (Refer to Figure 8-89a. The operation is completed in one word time and is repeated every  $1/8$  second. In the process, the time representation of the word is changed by an increment of  $1/8$  second.

The read and write portions of the counting operation take place concurrently. As the first data bit is shifted out of a register, the remaining bits shift one core to the right, leaving core number 1 vacant. Before the next shift operation takes place, the bit which has been shifted out of the register is cycled, instantaneously, through the arithmetic circuitry and inserted back into core number 1. The process is the same for each bit of the word. Thus, when the last bit of the original word is shifted out of the register, the first bit of the new one shifts into core number 24. The last bit then cycles through the arithmetic circuitry and enters core number 1, completing the counting operation.



# PROJECT GEMINI

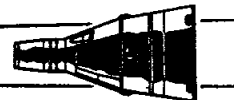

In the arithmetic portion of the counting process, the output of the elapsed time register is supplied to an add circuit and those from the  $T_R$  and  $T_X$  registers to separate subtract circuits. Both types of circuits are made up of combinations of logic and switching circuits. Their operation is quite similar, the main difference being in their logic programs.

The add process for the ET consists of adding a binary 1 to the first bit position, (the LSB) of the word coming into the add circuit. If there is already a 1 in that bit position, the 1 is carried to the next bit position. The carry operation continues until the 1 reaches an open bit position.

When the first bit of a data word read out of the ET register is a binary 0 the add circuit produces a positive output signal. The positive signal is then inverted by the write-in amplifier and supplied to the input of the storage register. With a negative input to the register, a binary 1 is written into core number 1 as the first bit of the new word. Thus, the first bit of the word has been changed from a binary 0 to a binary 1 adding  $1/8$  seconds to the representative time of the word. The remaining bits are written back into the register just as they were read out.

When a binary 1 is read out the ET register as the first bit of a data word, the output of the add circuit will be negative. Upon inversion by the write-in amplifier, the signal will be positive. A positive signal at the register input causes a binary 0 to be written into the first core. If the subsequent consecutive, data bits are also binary 1's, the output of the add circuit remains negative, causing binary 1's to be written into the register. Upon receipt of the first binary 0 in the data word from the register, the output of the add



# PROJECT GEMINI

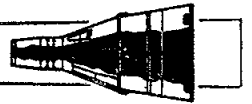

circuit becomes positive, causing a binary 1 to be written back into the register for that bit position. For example, if the first five bits of the word being read out of the register are binary 1's (representing a total of  $3 \frac{7}{8}$  seconds of ET) and the next one is a binary 0, then the first five bits of the new word will be binary 0's; and the sixth will be a binary 1. A binary 1 in the sixth bit position represents an ET of four seconds. The remaining bits of the data word, again, are inserted back into the register just as they were read out.

Although the circuitry of a subtract network is much the same as that of an add network, the operation is different because of the subtract logic. If the LSB of a word coming into a subtract network is a binary 1, the output for that bit position will be negative, causing a binary 0 to be written back into register. In this case, the  $1/8$  second has now been subtracted, and the balance of the word will remain the same. If the LSB of the incoming word is a binary 0 the output of the subtract network will become positive, allowing a binary 1 to be written into the register. The output of the subtract circuitry will remain positive until the first binary 1 enters the circuitry. When this occurs, the output becomes negative and causes a binary 0 to be written into the register. The rest of the word is then written back into the register just as it came out.

## Data Transfer

Binary words of time data are transferred into and out of the electronic timer by several different methods. Data words received from the ground station, via the DCS, are inserted directly into their respective storage registers in the timer. Data from the guidance system computer, however, is transferred into the buffer register of the timer and then shifted into the proper storage register.



# PROJECT GEMINI

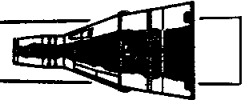

The same process is involved in the transfer of data from the timer to the computer: a word is shifted out of its storage register into the buffer register and then transferred to the computer. Data transfer from the timer to the Instrumentation System is accomplished by shifting the desired data out of its register to a pulse transformer. The output of the transformer is coupled to a storage register in the Instrumentation System.

## Timer Interfaces

The following is a list of the inputs and outputs of the electronic timer together with a brief description of each:

### INPUTS

- (a) A continuous 28 vdc signal from the spacecraft Sequential System at lift-off to start the recording of ET and countdown of  $T_R$  and  $T_X$ .
- (b) A 28 volt emergency start signal from the event timer to initiate the electronic timer operation in the event that the lift-off signal is not received from the Sequential System. The signal would be crew-ground co-ordinated and would be initiated by actuation of the event timer UP/DN switch to UP.
- (c) A Read/Write command signal from the digital computer to direct the timer as to which function is to be accomplished.
- (d) A TTG to  $T_R$  address signal from the digital computer to update or readout TTG to  $T_R$ .
- (e) A TTG to  $T_X$  address signal from the digital computer to enter a TTG to  $T_X$ .



# PROJECT GEMINI

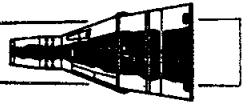

- (f) An elapsed time address signal from the digital computer to readout ET.
- (g) Twenty-four clock pulses from the digital computer to accomplish data transfer. (25 pulses for data transfer out of the electronic timer.)
- (h) Write data for update of T<sub>TG</sub> to T<sub>X</sub>, or T<sub>TG</sub> to T<sub>X</sub> from the digital computer. Twenty-four data bits will be forwarded serially, LSB first.
- (i) A T<sub>TG</sub> to T<sub>R</sub> ready signal from the DCS to command update of T<sub>TG</sub> to T<sub>R</sub>.
- (j) A T<sub>TG</sub> to T<sub>X</sub> ready signal from the DCS to command entry of a T<sub>TG</sub> to T<sub>X</sub>.
- (k) Serial data from the DCS to update T<sub>TG</sub> to T<sub>R</sub>, or T<sub>TG</sub> to T<sub>X</sub>. Twenty-four data bits will be forwarded serially, LSB first. Clocking is provided by the electronic timer.
- (l) T<sub>TG</sub> to T<sub>R</sub> readout signals from the Instrumentation System.
- (m) An elapsed time readout signal from the Instrumentation System.
- (n) An AGE/count inhibit signal from ground based equipment, via the spacecraft umbilical, to keep the elapsed time register at zero time prior to launch.
- (o) A clock hold signal from ground based equipment, via the spacecraft umbilical, to prevent the timer from operating prior to launch.
- (p) An event relay reset signal from ground based equipment, via the spacecraft umbilical.



# PROJECT GEMINI

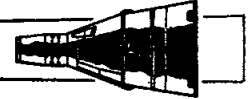

- (q) An event relay check signal from ground based equipment, via the spacecraft umbilical.

## OUTPUTS

- (a) A contact closure at  $T_R$  for the digital computer.
- (b) A contact closure at  $T_R$  (Continuous) for the Sequential System.
- (c) A contact closure at  $T_X$  for the DCS.
- (d) Read data to the digital computer for ET or TTG to  $T_R$ . Data bits are forwarded serially, LSB first.
- (e) Signal power ( $12 \begin{smallmatrix} +0 \\ -1 \end{smallmatrix}$  volts) to the DCS and Instrumentation System.
- (f) Twenty-four clock pulses to the DCS to accomplish data transfer.
- (g) Twenty-four clock pulses to the Instrumentation System to accomplish data transfer.
- (h) Serial data to the Instrumentation System for readout of ET or TTG to  $T_R$ . Data bits are forwarded serially, LSB first.
- (i) A contact closure from  $T_R-256$  seconds to  $T_R$  for the Sequential System.
- (j) A contact closure from  $T_R-30$  seconds to  $T_R$  for the Sequential System.
- (k) An input power monitor signal to ground based equipment via the spacecraft umbilical.

## TIME CORRELATION BUFFER

### General

The Time Correlation Buffer (TCB) supplies the time correlation signals for the bio-medical and voice tape recorder. Serial data and data clock output from



# PROJECT GEMINI



the electronic timer is applied to the TCB input. Serial data contains 24 elapsed time words, and extra elapsed time word and a time-to-go to retrograde word. The TCB selects the extra elapsed time word and modifies the word format to make it compatible with the tape recorder frequency responses. Information to the recorder is updated once every 2.4 seconds and has the same resolution (1/8 second) as the electronic timer.

## Construction

The dimensions of the TCB (Figure 8-84) are 2.77 x 3.75 x 3.80 inches and the weight is approximately 3.0 pounds. The TCB contains magnetic shift registers, a 100 kc astable multivibrator, a power supply and logic circuitry. One 19 pin connector provides both input and output connections.

## Operation

The operation of the TCB is dependent on signals from the Instrumentation System and the electronic timer. In response to request pulses from the Instrumentation System, the electronic timer provides elapsed time and time-to-go to retrograde words to both the Instrumentation System and the TCB. The elapsed time word is supplied every 100 milliseconds. In addition, once every 2.4 seconds it provides an extra elapsed time word and 100 milliseconds later it provides a time-to-go to retrograde word.

The TCB requires elapsed time information only, therefore, the time-to-go to retrograde word is rejected. The tape recorders, due to their response times, are not capable of recording time data every 100 milliseconds and for this reason only the extra elapsed time word is accepted by the TCB. The remaining 24 elapsed time words and the time-to-go to retrograde word are rejected by logic



# PROJECT GEMINI

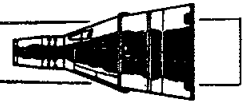

circuitry in the TCB. Rejection of unused words is based on their time relationship to other words.

The TCB contains three 8-bit magnetic shift registers in which the 24-bit extra elapsed time word is loaded once every 2.4 seconds. The TCB then shifts out bits at the rate of one every 100 milliseconds. The shift rate is based on data clock pulses from the electronic timer. The first data clock pulse in a word causes the TCB to shift out one bit of the data and the other 23 data clock pulses are disregarded.

Each bit that is shifted out of the shift register is stretched in time and coded to make it compatible with tape recorder response times. The output to the biomedical recorder is one positive pulse for a binary 0 and two positive pulses for a binary 1. The most significant bit has two additional pulses to distinguish it from the other 23 bits in the word. Data is shifted out of the TCB in a least significant bit first and most significant or marker bit last.

The output to the voice tape recorder is the same basic format as for the biomedical recorders. However, to make it compatible with the higher frequency response characteristics of the voice tape recorder, each output pulse is chopped into two pulses, doubling the frequency.

All input and output signals are coupled through isolation transformers providing complete DC isolation.

## MISSION ELAPSED TIME DIGITAL CLOCK

The mission elapsed time digital clock (used on spacecraft 6 through 12) is capable of counting time up to a maximum of 999 hours, 59 minutes and 59 seconds. The time



## PROJECT GEMINI



is displayed on a decimal display indicator on the face of the unit. The seconds tumbler of the display is further graduated in 0.2 second increments. Counting may be started or stopped manually. Prior to initiating a counting operation, the indicator should be electrically present to the desired starting time which normally starts from zero at lift-off and counts mission elapsed time in real time.

### Construction

The dimensions of the digital clock are approximately 2 inches by 4 inches by 6 inches and its weight is approximately 2 pounds. On the face of the clock there are two controls and a decimal display window. The unit contains four electronic modules, a relay and a step servo motor. A gear train connects the servo motor with the decimal display tumblers. An electrical connector is provided at the rear of the unit for power and signal inputs.

### Operation

Operation of the digital clock is dependent on timing pulses from the electronic timer. The time base used for normal counting operations in the digital clock is derived from the 8 pps timing pulse output of the electronic timer. The 8 pps signal is buffered and used to establish the repetition rate of a step servo motor. The step servo motor is coupled through a gear train to display tumblers. Additional counting rates are selectable for the purpose of setting the clock to a desired starting point.

### Start/Stop Operation

Remote starting of the digital clock is accomplished by providing the 8 pps timing pulses from the electronic timer. Before remote starting can be accomplished, the START/STOP switch must be in the START position and the DECR/INCR



# PROJECT GEMINI

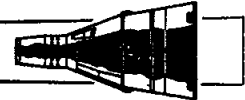

switch must be in the 0 position. Manual starting of the digital clock can be accomplished (if timing pulses are available) by placing the START/STOP switch in the START position. This energizes the start side of the start/stop magnetic latching relay. The relay applies control and operating voltages to the counting circuitry, allowing the counting operation to begin. Counting may be stopped by removing the time base (8 pps) from the clock or by placing the START/STOP switch in the STOP position, removing voltage and disabling the circuitry.

## Counting Operations

When the start/stop relays are actuated and operating voltage of plus 28 volts dc applied to the servo motor, a plus 12 volt dc enable signal is applied to the normal count gate. This initiates the counting sequence. The electronic timer provides and 8 pps timing signal which is buffered and supplied to the sequential logic section.

Sequential logic section consists of four set-reset flip flops which provide the necessary sequences of output signals to cause the servomotor to step in one direction of the other (Figure 8-91). As the counting process begins, three of the flip flops are in the reset condition (reset output positive) and one is in the set condition (set output positive). With receipt of the first timing pulse, the next flip flop switches to the set condition. The first one also remains set, but the other two remain reset. Then, when another timing pulse is received, the first flip flop resets, leaving only the second one set. The sequence continues with alternate timing pulses setting one flip flop, then resetting the preceding one. After the fourth flip flop has been set and the third one subsequently reset, the first one is again switched to the set condition and the sequence is started over again. In order to have the logic

PROJECT GEMINI

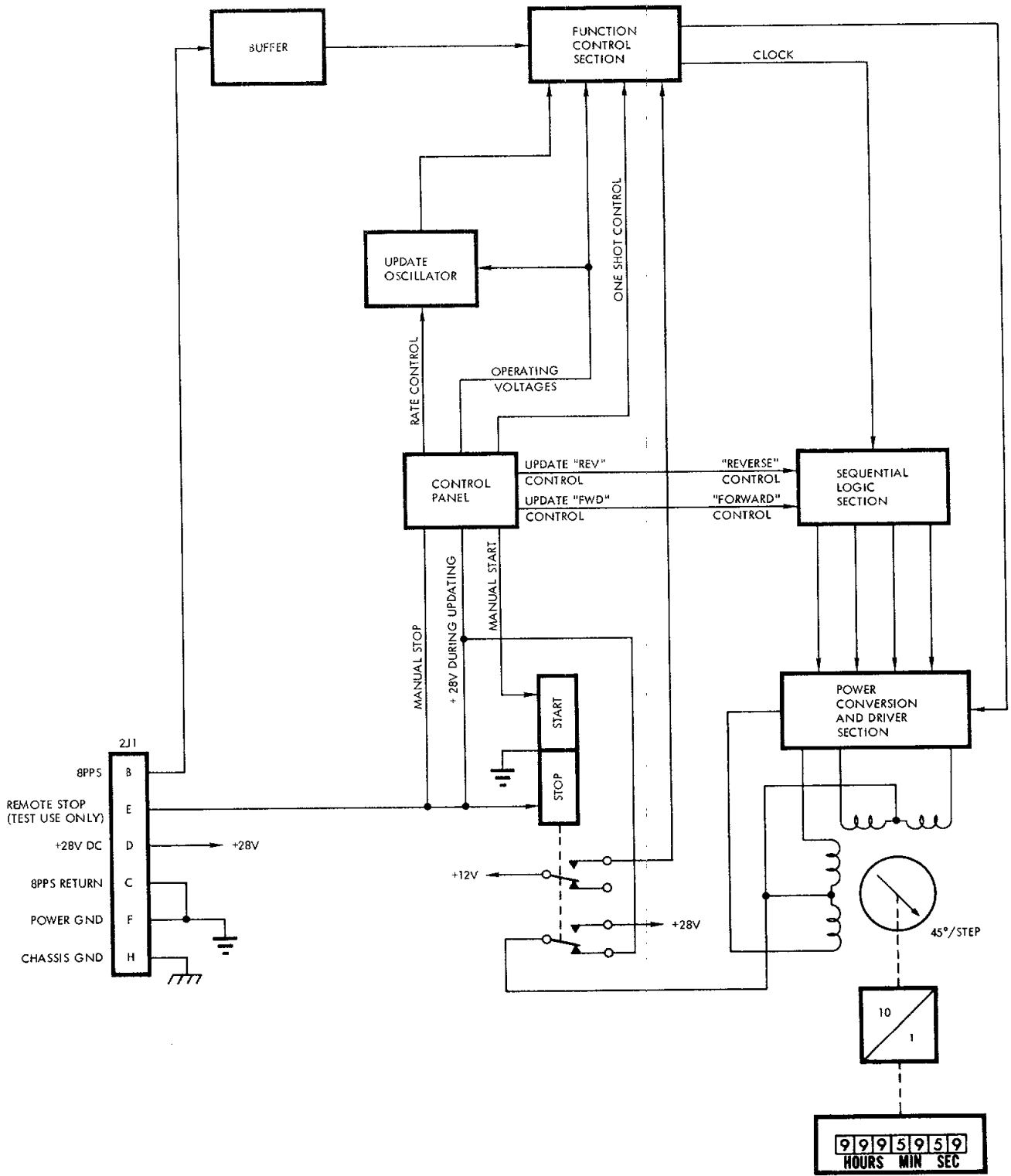
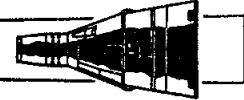

Figure 8-91 Mission Elapsed Time Digital Clock Functional Diagram



# PROJECT GEMINI



section function properly, either a forward or reverse control signal must be received from the start/stop relay. These are used as steering signals for the timing pulses which set and reset the flip flops. For counting up, the control signals cause the flip flop operating sequence to be in one direction. When counting down, they cause the sequence to reverse; flip flop number 4 is set first, then number 3, etc., back through number 1. The output of the sequential logic circuit is applied to the power conversion and driver section.

The power conversion and driver section converts the voltage-pulse outputs of the logic section to current pulses which are used to drive the servomotor. The driver section provides four separate channels, one for each input. Each channel has a logic gate and a power driver. The logic gate permits the logic section output to be sensed at ten selected times each second. The gate senses only the occurrence of a positive signal which will allow the power driver to conduct and send a pulse of current through one of the four servomotor stator windings.

The sequence of pulses from the driver section causes the servomotor to step eight times each second and  $45^\circ$  each step. Figure 8-92 illustrates the step positions relative to the sequence of operating pulses from the driver section. If pulses were applied to each of the four servomotor windings, without overlap, the unit would step  $90^\circ$  each repetition. It is this overlapping of signal applications which causes it to step  $45^\circ$  at a time.

The display indicator is a rotating counter with wheels to display seconds, tens of seconds, minutes, and tens of minutes, hours, tens of hours and hundreds of hours. It is coupled to the servomotor through a gear train with a reduction ratio, from the servomotor, of 10:1. Therefore, as the servomotor rotates  $360^\circ$

**PROJECT GEMINI**

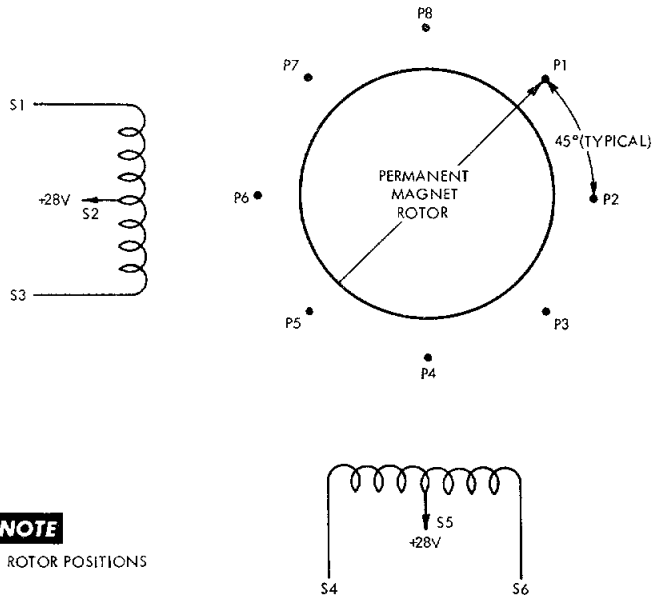

OPERATION	RESULT
GROUND S1, GROUND S6	ROTOR INDEXES TO ARBITRARY REF. POSITION (P1)
OPEN S1	ROTOR STEPS 45° C. W. (P2)
GROUND S3	ROTOR STEPS 45° C. W. (P3)
OPEN S6	ROTOR STEPS 45° C. W. (P4)
GROUND S4	ROTOR STEPS 45° C. W. (P5)
OPEN S3	ROTOR STEPS 45° C. W. (P6)
GROUND S1	ROTOR STEPS 45° C. W. (P7)
OPEN S4	ROTOR STEPS 45° C. W. (P8)
GROUND S6	ROTOR RETURNS TO REF. POSITION (P1)
OPEN S6	ROTOR STEPS 45° C. C. W. (P8)
GROUND S4	ROTOR STEPS 45° C. C. W. (P7)
OPEN S1	ROTOR STEPS 45° C. C. W. (P6)
GROUND S3	ROTOR STEPS 45° C. C. W. (P5)
OPEN S4	ROTOR STEPS 45° C. C. W. (P4)
GROUND S6	ROTOR STEPS 45° C. C. W. (P3)
OPEN S3	ROTOR STEPS 45° C. C. W. (P2)
GROUND S1	ROTOR RETURNS TO REF. POSITION (P1)

Figure 8-92 Step Servomotor Operation



# PROJECT GEMINI

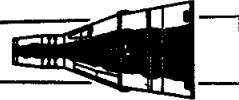

(in one second), the indicator shaft turns  $36^{\circ}$  or  $1/8$  of a rotation. Since the seconds wheel is directly coupled to the shaft and is calibrated from zero to nine, a new decimal is displayed each second. As the seconds wheel moves from nine to zero, the tens-of-seconds wheel moves to the one position. The operations of the other wheels are similar.

## Updating

The display may be returned to zero or updated to some other readout with the use of the DECR-INCR rotary switch on the face of the timer. The rotary switch must be in the 0 position in order to have the timer operate at a normal rate; with the switch in one of the other position, it counts at a different rate. There are three rate selections, each for the INCR and DECR (count-up and count-down) updating modes. The positions on each side that are farthest from the 0 position are utilized to make the timer count at 25 times its normal rate. The next closer positions are utilized to count at three times the normal rate. The positions nearest the 0 position are used to count at a rate 0.3 times the normal one. This position serves to more accurately place the indicator at a desired readout.

Operationally, positioning the rotary switch in some position other than 0 causes the time base frequency from the electronic timer to be replaced in the circuitry by an update oscillator. The frequency of the oscillator is established by the position of the rotary switch. In the 25X positions, the frequency is 400 cycles per second; in the 3X position, it is 48 cps; and in the 0.3X positions, it is approximately 4.8 cycles per second. The accuracy of the oscillator output is not critical since the oscillator functions only for updating purposes.



# PROJECT GEMINI



Operation of rotary switch supplies a stop command to the electronic circuitry, and start switch must be operated to resume normal count.

## EVENT TIMER

### General

The event timer is capable of counting time, either up or down, to a maximum of 59 minutes and 59 seconds. The time is capable of counting time down to zero from any preselected time, up to the maximum listed above.

### **NOTE**

When the event timer is counting down, it will continue through zero if not manually stopped. After counting through zero, the timer will begin counting down from 59 minutes and 59 seconds.

The time is displayed on a decimal display indicator on the face of the unit. The seconds tumbler of the display indicator is further graduated in 0.2 second increments. Counting, in either direction, may be started or stopped either remotely or manually. Prior to starting a counting operation, the indicator must be manually preset to the time from which it is desired to start counting.

### Construction

The dimensions of the event time are approximately 2 x 4 x 6 inches and the weight about two pounds. On the face of the timer, there are two toggle switches, one rotary switch, and a decimal display window. (Refer to Figure 8-84) In addition to the panel-mounted controls, the unit contains four electronic modules, two relays, a tuning fork resonator, and a step servo motor. A gear train connects



# PROJECT GEMINI



the servo motor with the decimal display tumblers. There is one electrical connector on the back of the unit.

## Operation

The operation of the event timer is independent of the electronic timer. (Refer to Figure 8-93) It provides its own time base which is used to control the operation of the decimal display mechanism. The time base used for normal counting operation is developed when the output of a tuning fork resonator is connected to a series of toggle-type flip flops. The resulting signal establishes the repetition rate of a step-type servo motor. The servo motor is coupled, through a gear train, to the display tumblers. Additional counting rates may be selected in order to rapidly reset the timer to zero or to some other desired indication.

## Start/Stop Operations

The remote and manual start/stop functions of the timer are accomplished in almost exactly the same manner. The difference is only in the source of the control signals. In order to initiate counting operations by either method, it is necessary to first have the STOP-STBY toggle switch in either the STBY or the center off position. (Refer to Figure 8-84)

### **NOTE**

When starting is accomplished with the STOP - STBY switch in the center position, a small inaccuracy is incurred. To prevent any starting inaccuracies, the STOP - STBY switch is placed in the STBY position before starting the timer.

Manual starting may then be accomplished by placing the UP-DN toggle switch in either the UP or the DN position. This energizes one of the two coils of the

# PROJECT GEMINI

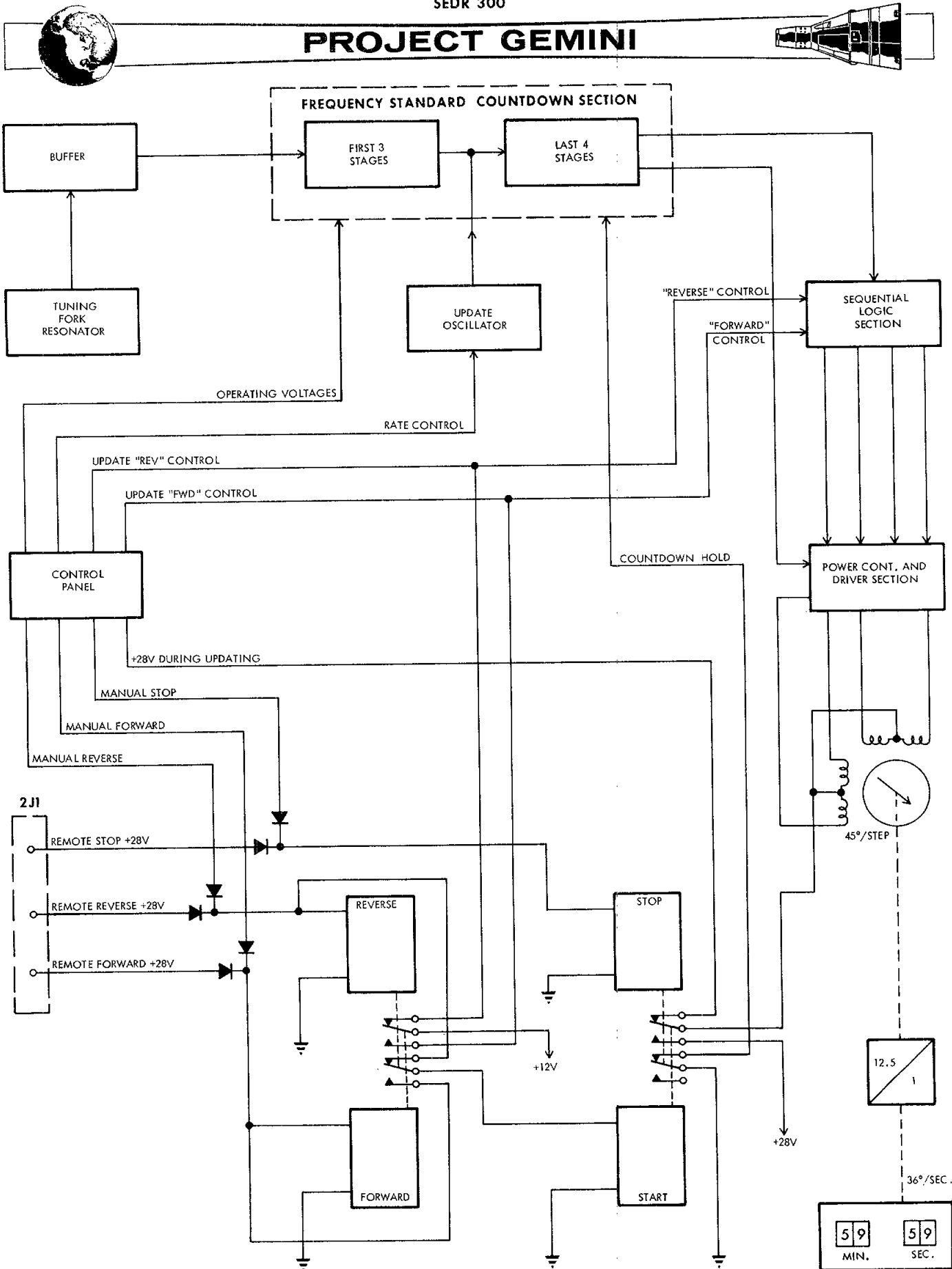
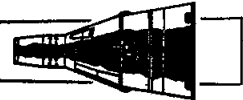

Figure 8-93 Event Timer Functional Diagram

8-335



# PROJECT GEMINI



forward/reverse relay, also causing the start coil of the start/stop relay to be energized. When these events take place, control and operating voltages are supplied to the counting circuitry, thus allowing the operation to begin. When starting is to be accomplished remotely, either a remote forward or a remote reverse signal is transmitted from the ground station to energize the forward/reverse relay. The counting process may be stopped upon receipt of a remote stop signal or by placing the STOP-STBY switch in the STOP position. Either of these functions energizes the stop side of the start/stop relay, removing critical operating voltages from the counting circuitry.

## Counting Operations

Normal counting operations begin with the actuation of the forward/reverse relay in either direction and the start/stop relay in the start direction. When the forward/reverse and the start/stop relays are actuated, an operating voltage of +28 vdc is applied to the servo motor and a ground level inhibit signal is removed from the toggle flip flops. Also, a +12 vdc control signal, denoting either a forward or reverse counting process, is transmitted to the logic circuitry preceding the servo motor. The remainder of the timer circuitry has operating voltages applied when the STOP/STBY switch is placed in STBY.

With the application of operating voltages, the tuning fork resonator emits an ac signal of 1280 cycles per second. The signal is passed through a buffer to condition it for use by the series of seven toggle flip flops in the frequency standard countdown section. Since the output frequency of each flip flop is half that of its input, the final one in the series generates a signal of ten pulses per second. The outputs of the countdown section are connected to the sequential logic section and the power conversion and driver section.



# PROJECT GEMINI

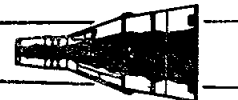

Sequential logic section consists of four set-reset flip flops which provide the necessary sequences of output signals to cause the servo motor to step in one direction or the other (Figure 8-93). As the counting process begins, three of the flip flops are in the reset condition (reset output positive) and one is in the set condition (set output positive). With receipt of the first timing pulse, the next flip flop switches to the set condition. The first one also remains set, but the other two remain reset. Then, when another timing pulse is received, the first flip flop resets, leaving only the second one set. The sequence continues with alternate timing pulses setting one flip flop, then resetting the preceding one. After the fourth flip flop has been set and the third one subsequently reset, the first one is again switched to the set condition and the sequence is started over again. In order to have the logic section function properly, either a forward or reverse control signal must be received from the forward/reverse relay. These are used as steering signals for the timing pulses which set and reset the flip flops. For counting up, the control signals cause the flip flop operating sequence to be in one direction. When counting down, they cause the sequence to reverse: flip flop number 4 is set first, then number 3, etc., back through number 1.

The power conversion and driver section converts the voltage-pulse outputs of the logic section to current pulses which are used to drive the servo motor. The driver section provides four separate channels, one for each input. Each channel has a logic gate and a power driver. The logic gate permits the logic section output to be sensed at ten selected times each second. The gate senses only the occurrence of a positive signal which will allow the power driver to conduct and send a pulse of current through one of the four servo motor stator windings.



# PROJECT GEMINI

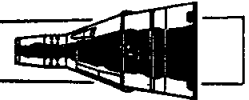

The sequence of pulses from the driver section causes the servomotor to step ten times each second and  $45^{\circ}$  each step. Figure 8-92 illustrates the step positions relative to the sequence of operating pulses from the driver section. If pulses were applied to each of the four servomotor windings, without overlap, the unit would step  $90^{\circ}$  each repetition. It is this overlapping of signal applications which causes it to step  $45^{\circ}$  at a time.

The display indicator is a rotating counter with wheels to display seconds, tens of seconds, minutes, and tens of minutes. It is coupled to the servomotor through a gear train with a reduction ratio, from the servomotor, of 12.5:1. Therefore, as the servomotor rotates  $450^{\circ}$  (in one second), the indicator shaft turns  $36^{\circ}$  or  $1/10$  of a rotation. Since the seconds wheel is directly coupled to the shaft and is calibrated from zero to nine, a new decimal is displayed each second. As the seconds wheel from nine to zero, the tens-of-seconds wheel moves to the one position. The operations of the other wheels are similar.

## Updating

The display may be returned to zero or updated to some other readout with the use of the DECR-INCR rotary switch on the face of the timer. The rotary switch must be in the 0 position in order to have the timer operate at a normal rate; with the switch in one of the other positions, it counts at a different rate. There are three rate selections, each, for the INCR and DECR (count-up and count-down) updating modes. The positions on each side that are farthest from the 0 position are utilized to make the timer count at 25 times its normal rate. The next closer positions are utilized to count at four times the normal rate. The position nearest the 0 position are used to count at a rate 0.4 times the



# PROJECT GEMINI

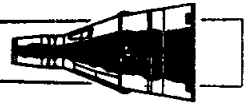

the normal one. This position serves to more accurately place the indicator at a desired readout.

Operationally, positioning the rotary switch in some position other than 0 causes the tuning fork resonator and the first three toggle flip flops to be replaced in the circuitry by an update oscillator. The frequency of the oscillator is established by the position of the rotary switch. In the 25X positions, the frequency is 4,000 cycles per second; in the 4X position, it is 640 cps; and in the 0.4X positions, it is approximately 64 cycles per second. The accuracy of the oscillator output is not critical since the oscillator functions only for updating purposes.

## ACCUTRON CLOCK

The Accutron clock (Figure 8-84), located on the command pilot's control panel. The clock is approximately  $2 \frac{3}{8}$  inches square and one inch thick. The clock has a 24 hour dial with major divisions on the half hour. An hour hand, minute hand and a sweep second hand are provided for a precise indication of the time of day. The unit is completely self contained and has no electrical interface with the spacecraft. The clock is capable of operating continuously for approximately one year on the internal mercury battery.

## Operation

The Accutron clock is provided with one control knob. The knob is used to stop, set and start the timer as desired. To stop the timer, the control is depressed. From the depressed position, the clock can be set to the desired time. The clock will start automatically when the control knob is released.



## PROJECT GEMINI

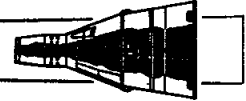

The Accutron clock is a highly accurate device with an error of less than  $\pm 3$  seconds per day. This high degree of accuracy is made possible by using a tuning fork as the time standard, instead of the conventional balance wheel and hair spring. The tuning fork is magnetically driven at a natural frequency of 360 cps. The tuning fork frequency is adjustable, making precise calibration of the clock possible. The vibrational motion of the tuning fork is converted to rotational motion to provide outputs of: one revolution per day, one revolution per hour and one revolution per minute, for the clock hands.

### MECHANICAL CLOCK

#### Construction

The mechanical clock is shown in Figure 8-84. The unit is approximately  $2 \frac{1}{4}$  x  $2 \frac{1}{4}$  x  $3 \frac{1}{4}$  inches and weighs about one pound. The dial face is calibrated in increments of 0-24 and 0-60. The clock has two hands for the time of day portion and two for the stopwatch portion. The controls for operating both portions of the clock are located on the face of the unit.

#### Operation

The clock is a mechanical device which is self-powered and required no outside inputs. The hand and dial-face clock displays Greenwich Mean Time in hours and minutes. A control on the face provides for winding and setting the unit. With the passing of each 24-hour period, the calendar date indicator advances to the next consecutive number. The stopwatch portion of the clock can be started, stopped, and returned to zero at any time. Two settable markers are provided on the minute dial to provide a time memory, permitting the clock to serve as a short-term back-up timer.

# PROPULSION SYSTEMS

## TABLE OF CONTENTS

TITLE	PAGE
GENERAL INFORMATION. . . . .	8-343
ORBIT ATTITUDE AND MANEUVERING SYSTEM. . . . .	8-343
SYSTEM DESCRIPTION. . . . .	8-343
SYSTEM OPERATION. . . . .	8-349
SYSTEM UNITS. . . . .	8-352
RE-ENTRY CONTROL SYSTEM. . . . .	8-369
SYSTEM DESCRIPTION. . . . .	8-369
SYSTEM OPERATION. . . . .	8-374
SYSTEM UNITS. . . . .	8-376

# PROJECT GEMINI

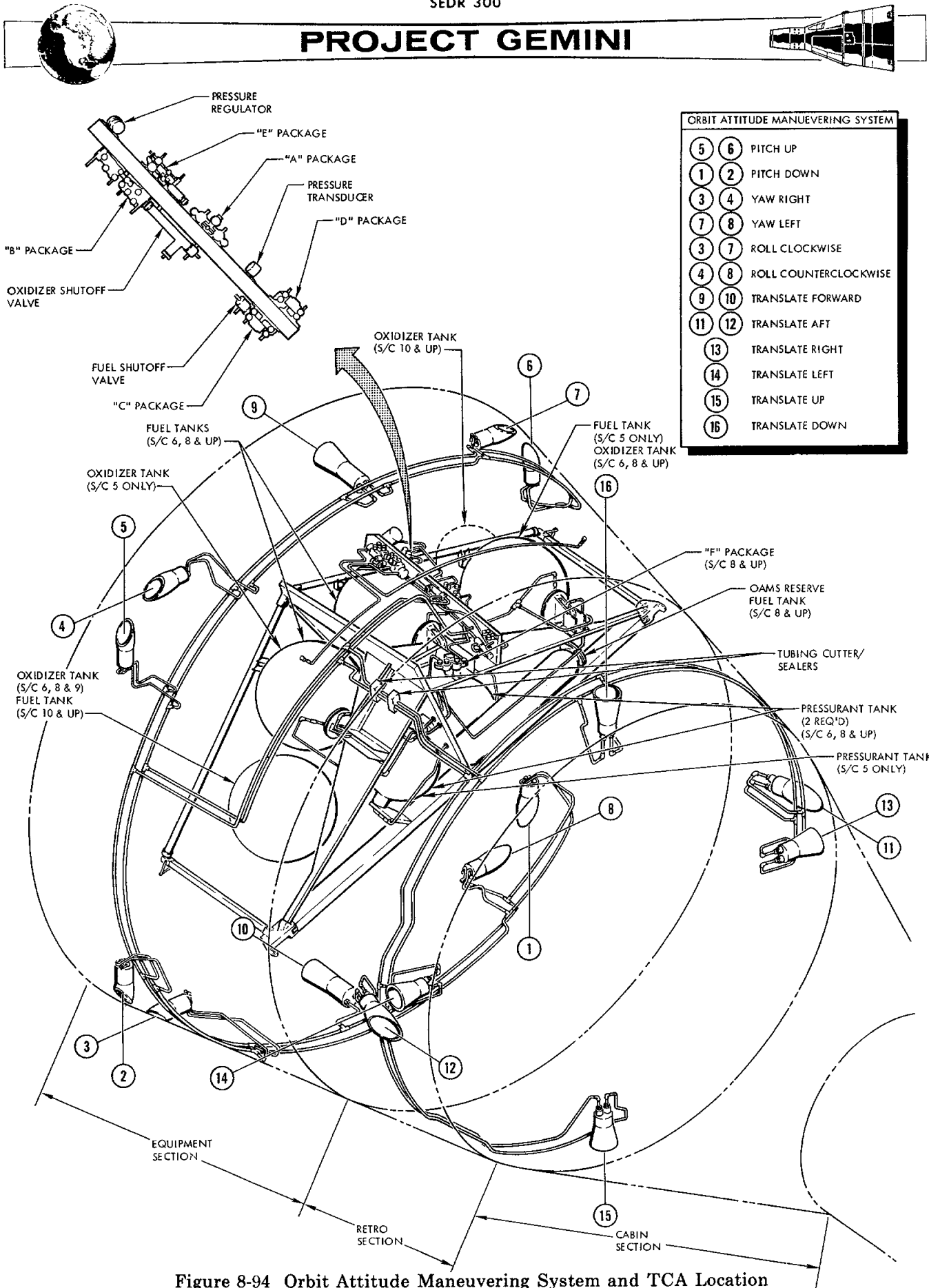

Figure 8-94 Orbit Attitude Maneuvering System and TCA Location



# PROJECT GEMINI



## PROPULSION SYSTEM

### GENERAL INFORMATION

The Gemini Spacecraft is provided with an attitude and maneuvering control capability. (Figure 8-94). This control capability is used during the entire spacecraft mission, from the time of launch vehicle separation until the re-entry phase is completed. Spacecraft control is accomplished by two rocket engine systems, the Orbit Attitude and Maneuvering System (OAMS) and the Re-entry Control System (RCS).

The OAMS controls the spacecraft attitude and provides maneuver capability from the time of launch vehicle separation until the initiation of the retrograde phase of the mission. The RCS provides attitude control for the re-entry module during the re-entry phase of the mission. The OAMS and RCS respond to electrical commands from the Attitude Control Maneuvering Electronics (ACME) in the automatic mode or from the crew in the manual mode.

### ORBIT ATTITUDE AND MANEUVERING SYSTEM

#### SYSTEM DESCRIPTION

The Orbit Attitude Maneuvering System (OAMS) (Figure 8-94) is a fixed thrust, cold gas pressurized, storable liquid, hypergolic bi-propellant, self contained propulsion system, which is capable of operating in the environment outside the earth's atmosphere. Maneuvering capability is obtained by firing thrust chamber assemblies (TCA) singly or in groups. The thrust chamber assemblies are mounted at various points about the adapter in locations consistent with the modes of rotational or translation acceleration required.

# PROJECT GEMINI

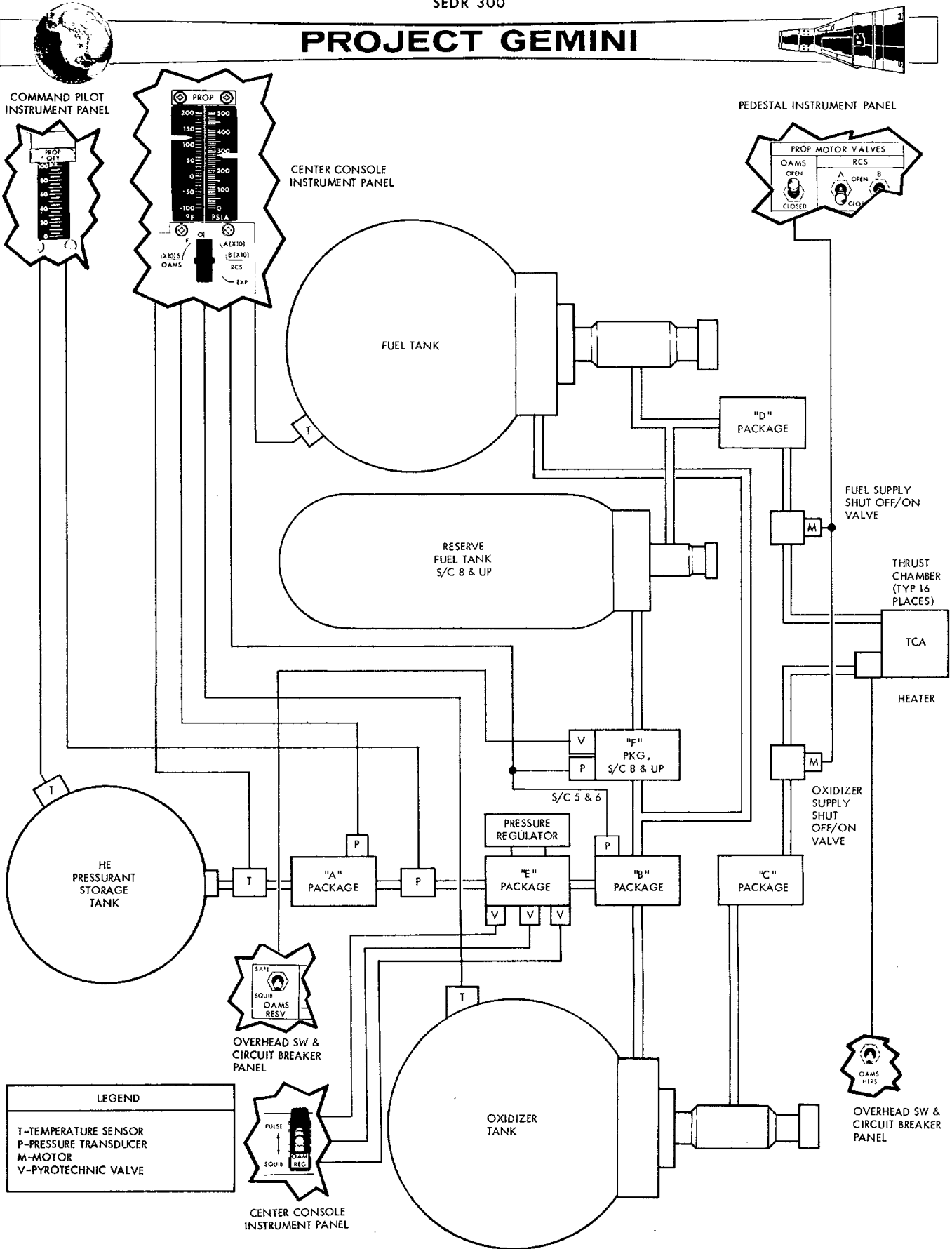

Figure 8-95 OAMS Control & Indicator Schematic



# PROJECT GEMINI



The OAMS provides a means of rotating the spacecraft about its three attitude control axes (roll, pitch, and yaw) and translation control in six directions (right, left, up, down, forward and aft). The combination of attitude and translational maneuvering creates the capability of rendezvous and docking with another space vehicle in orbit.

The primary purpose of OAMS is spacecraft control in orbit. The OAMS is also used, after firing of shaped charges, to separate the spacecraft from the launch vehicle during a normal launch or in case of an abort which may occur late in the launch phase. During initiation of retrograde sequence, tubing cutter/sealer devices sever and seal the propellant feed lines from the equipment adapter. All of the OAMS (except six TCA's located in retro section) are separated from the spacecraft with the equipment section of the adapter. Spacecraft control functions are then assumed by the Re-entry Control System (RCS). OAMS control units and tanks are mounted on a structural frame (module concept) in the equipment section. The control units consist of forged and welded "packages". Each package consists of several functioning components and filters. The OAMS Control and Indicator Schematic (Figure 8-95) is a simplified schematic of the indicators and manual controls which are directly related to the Propulsion System. Additional controls are provided by the Attitude Control and Maneuvering Electronics (ACME) System. The delivery of pressurant, fuel and oxidizer is accomplished by a uniquely brazed tubing manifold system. The OAMS system is divided into three groups; pressurant group, fuel/oxidizer group and Thrust Chamber Assembly (TCA) group.

## Pressurant Group

The pressurant group (Figure 8-96) consists of a pressurant tank, "A" package,

# PROJECT GEMINI

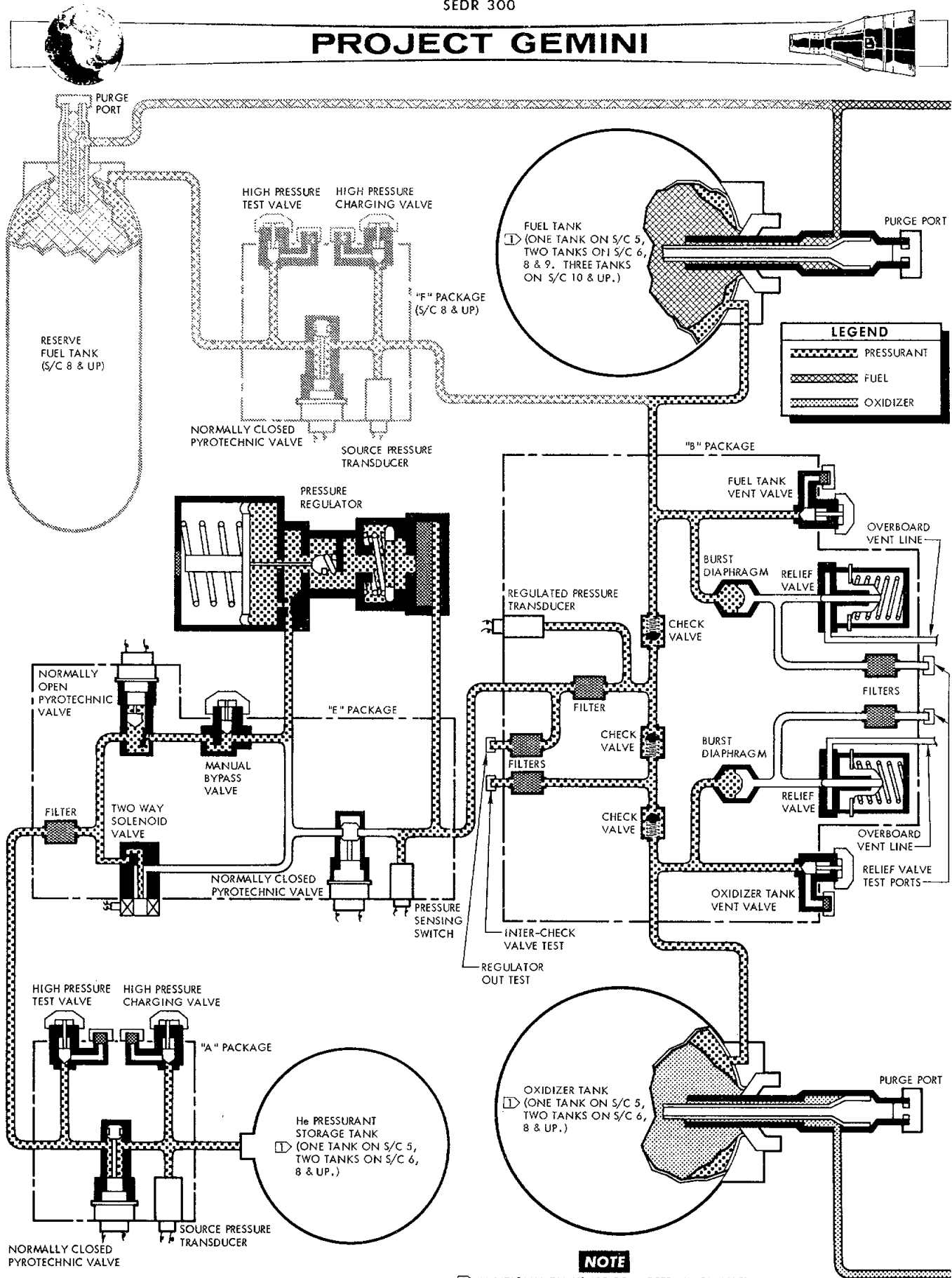

Figure 8-96 Orbit Attitude Maneuvering System Schematic (Sheet 1 of 2)

# PROJECT GEMINI

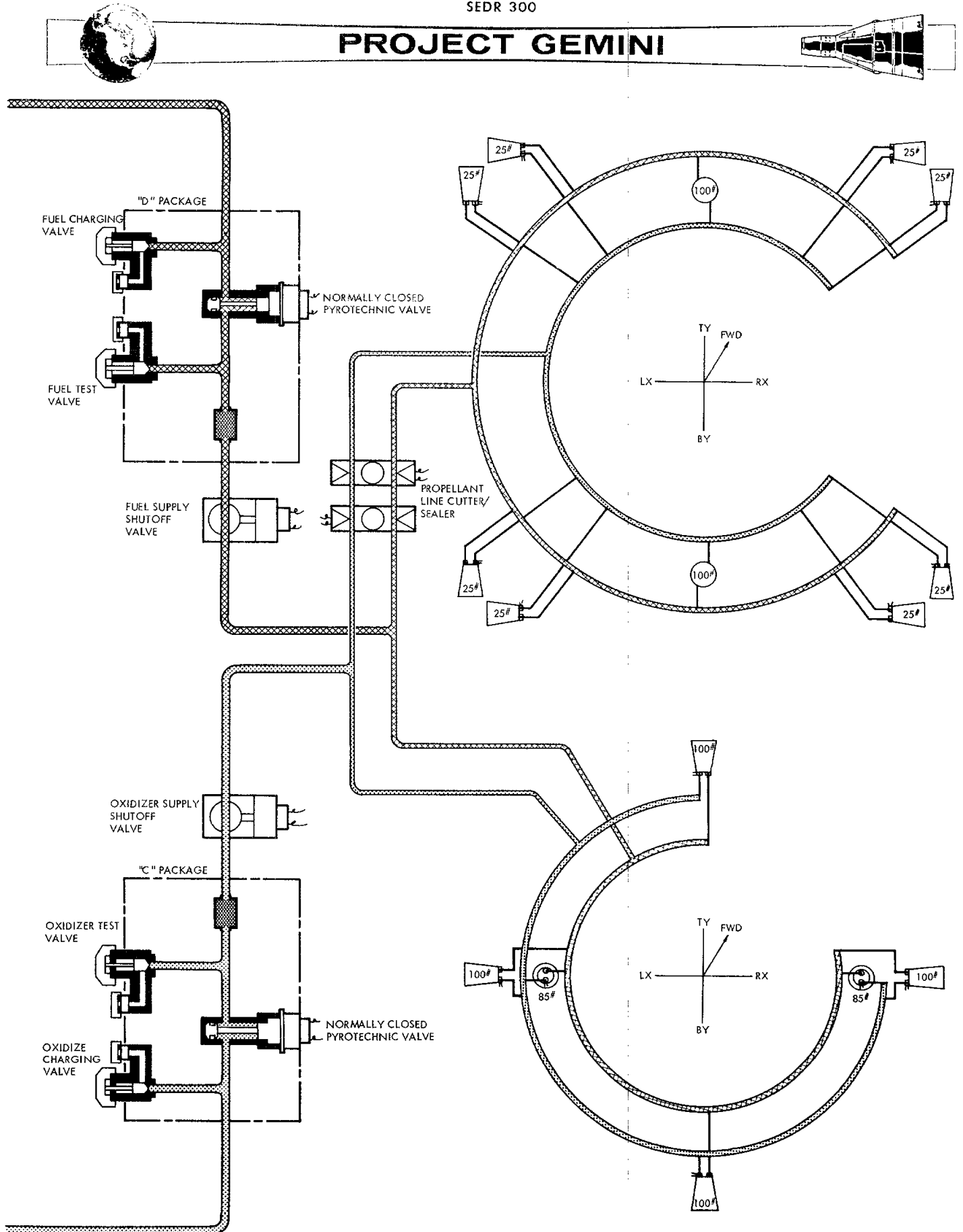

Figure 8-96 Orbit Attitude Maneuvering System Schematic (Sheet 2 of 2)



# PROJECT GEMINI



"E" package, "F" package on Spacecraft 8 thru 12, pressure regulator, and "B" package. Inlet valves, ports and test ports are provided at accessible points to permit servicing, venting, purging and testing. Filters are provided throughout the system to prevent contamination of the system. The pressurant is isolated in the storage tank during pre-launch periods by a normally closed pyrotechnic actuated valve, located in the "A" package. On Spacecraft 8 thru 12, the pressurant is isolated from the reserve fuel tank by the "F" package.

## Fuel/Oxidizer Group

The fuel/oxidizer (propellant) group (Figure 8-96) consists of expulsion bladder storage tanks, "C" and "D" packages and two propellant shut off valves. Charging valves and ports and test valves and ports are provided at accessible points to permit servicing, venting, purging and testing. The propellants are isolated in the storage tanks by normally closed, pyrotechnic actuated valves ("C" and "D" packages). Filters are provided in the "C" and "D" packages, down stream of the isolation valves, to guard against contamination of the thrust chamber assemblies.

The propellants used are:

OXIDIZER - nitrogen tetroxide ( $N_2O_4$ ) conforming to  
specification MIL - P - 26539 A

FUEL - monomethyl hydrazine ( $N_2H_3CH_3$ ) conforming  
to specification MIL - P - 27404

## Thrust Chamber Assembly (TCA) Group

The TCA group consists of thrust chambers and electrical solenoid valves. Sixteen TCA's are used per spacecraft (Figure 8-94). Eight twenty-five pound thrust capacity TCA's are used for attitude control, (roll, pitch and yaw). Six one-



# PROJECT GEMINI



hundred pound and two eight-five pound thrust capacity TCA's are used for translational maneuvering.

## SYSTEM OPERATION

### Pressurant Group

The pressurant tank contains high pressure helium (He) stored at 3000 PSI. (Figure 8-96). The tank is serviced through the "A" package high pressure gas charging port. Pressure from the pressurant tank is isolated from the remainder of the system by a normally closed pyrotechnic actuated isolation valve located in the "A" package. Upon command, the system isolation valve is opened and pressurized helium flows through the "E" package, to the pressure regulator, "B" package and propellant tanks. Normally, pressurant is controlled through system pressure regulator, and regulated pressure flows to the "B" package. The "B" package serves to deliver pressurant at regulated pressure to the fuel and oxidizer tanks, imposing pressure on the propellant tank bladder exteriors. Relief valves in the "B" package prevent over pressurization of the system downstream of the regulator. Burst diaphragms are provided in series with the relief valves, in the "B" package, to provide a positive leak tight seal between system pressure and the relief valve.

The "E" package provides a secondary mode of pressure regulation in the event of regulator failure. In the event of regulator over-pressure failure, resulting in excess pressure passage through the regulator, a pressure switch ("E" package) intervenes and automatically closes the normally open cartridge valve. Regulated pressure is then controlled manually by the crew by momentary placing the OAMS-



# PROJECT GEMINI



REG switch in the PULSE position. (Figure 8-95). Control pressure information is obtained from the "B" package regulated pressure transducer on spacecraft 5 and 6, the "F" package pressure transducer on spacecraft 8 thru 12. Should regulator under-pressure failure occur, the crew can manually select the OAMS-REG switch to SQUIB. This selection opens the normally closed valve and closes the normally open valve, thus pressurant by-passes the regulator completely. Pressure is then regulated manually (OAMS-PULSE) by the crew with control pressure information obtained from the "B" package regulated pressure transducer on spacecraft 5 and 6, the "F" package pressure transducer on spacecraft 8 thru 12. The "B" package provides a division of pressurant flow to the propellant tanks. The regulated pressure is sensed by the pressure transducer and provides a signal to the cabin instrument, (Figure 8-95) indicating pressure downstream of the regulator. In the event of regulator failure, the crew utilizes the reading to manually maintain the required pressure in the system. Three check valves prevent back flow of propellant vapors into the pressurant system. The "B" package also affords a safety feature for prevention of over pressure on the fuel and oxidizer tank bladders. Should the system be over pressureized downstream of the regulator the over pressure would first rupture the burst diaphragms, then be vented over-board through the relief valves. The relief valves will reset when system pressure returns to normal.

On spacecraft 8 thru 12, the pressurant flows from the "B" package to the "F" package. The normally closed pyrotechnic valve in the "F" package is opened by placing the OAMS RESV switch (Figure 8-95) in the SQUIB position, allowing pressurant to flow to the reserve fuel tank.



# PROJECT GEMINI



## Fuel/Oxidizer Group

Fuel and oxidizer are stored in their respective tanks and are isolated from the remainder of the system by normally closed pyrotechnic valves in the "C" (oxidizer) and "D" (fuel) packages. Upon command, the "A" (pressurant), "C" and "D" package isolation valves are opened. The pressurant imposes pressure on the propellant tank bladders and fuel and oxidizer are distributed through their separate tubing manifold systems to the inlet of the thrust chamber solenoid valves. Upon command on spacecraft 8 thru 12, the normally closed pyrotechnic valve in the "F" package is opened to allow pressurant to impose pressure on the reserve fuel tank bladder to distribute reserve fuel to the thrust chamber solenoid valve. Two electrically operated motor control valves (Figure 8-95) are located in the propellant feed lines, upstream of the TCS's. In the event of fuel or oxidizer leakage through the TCA solenoid valves, the motor operated valves can be closed by the crew to prevent loss of propellants. The valves can again be actuated open by the crew, when required, to deliver propellants to TCA solenoids.

## Thrust Chamber Assembly (TCA) Group

Upon command from the automatic or manual controls, signals are transmitted through the Attitude Control Maneuvering Electronics (ACME) to selected TCA's to open simultaneously the normally closed, quick-acting fuel and oxidizer solenoid valves mounted on each TCA. In response to these commands, propellants are directed through small injector jets into the combustion chamber. The controlled fuel and oxidizer impinge on one another, where they ignite hypergolically to burn and create thrust. Heaters are connected to each TCA oxidizer solenoid valve to prevent freeze-up and are activated by an OAMS HTRS switch (Figure 8-95).



# PROJECT GEMINI



## SYSTEM UNITS

### Pressurant Storage Tank

The helium pressurant is stored in welded, titanium spherical tank. Tank dimension is 16.20 inches outside diameter and has an internal volume of 1696.0 cubic inches. The helium gas is stored at 3000 psi and held therein by the "A" package normally closed pyrotechnic actuated valve. The pressurized helium is used to expel the fuel and oxidizer from their respective tanks. Temperature sensors are affixed to the pressurant tank and outlet line to provide readings for the cabin instrument and telemetry.

### "A" Package

The "A" package (Figure 8-97) consists of a source pressure transducer, isolation valve, two high pressure gas charging and test valves and filters. The source pressure transducer monitors tank pressure and transmits an electric signal to the propellant indicator in the cabin and to the Instrumentation System. The normally closed pyrotechnic isolation valve is used to isolate pressure from the remainder of the system. The valve is actuated to the open position to activate the system for operation. Two dual seal, high pressure gas charging valves and ports are provided, one on each side of the isolation valve. The upstream valve is used for servicing, purging and venting the pressurant tank, while the downstream valve is used to test downstream components. The valve filters prevent system contamination during testing and servicing.

### "F" Package (Spacecraft 8 thru 12 Only)

The "F" package (Figure 8-97) consists of a source pressure transducer, isolation

# PROJECT GEMINI

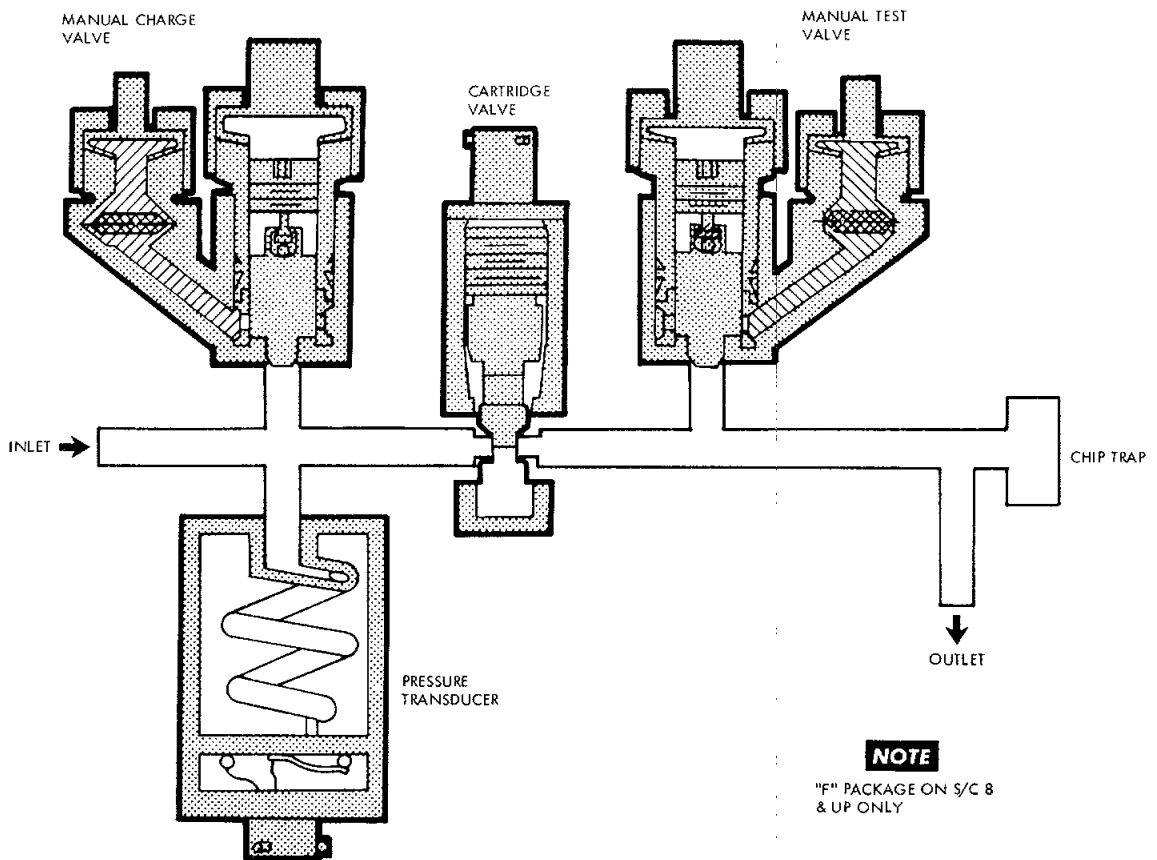
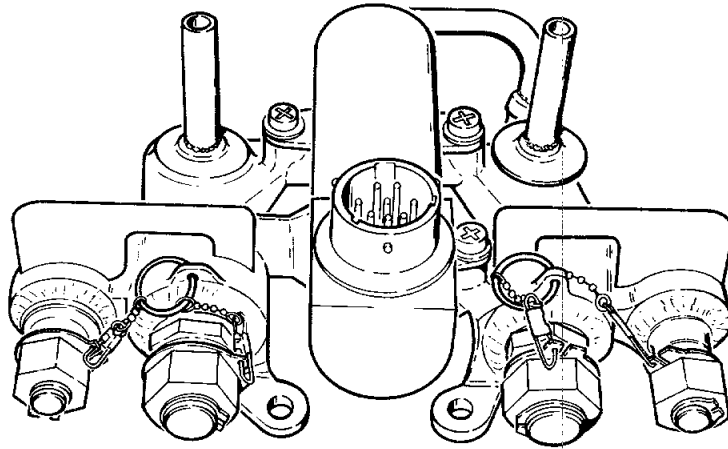
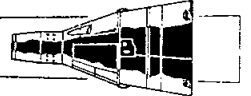

Figure 8-97 OAMS and RCS "A" Package and OAMS "F" Package



## PROJECT GEMINI



valve, two high pressure gas charging and test valves and filters. The source pressure transducer monitors the regulated pressure and transmits an electrical signal to the cabin indicator and Instrumentation System, indicating the amount of regulated pressure for the OAMS system. The normally closed pyrotechnic valve is used to isolate the pressurant from the reserve fuel tank. The valve is actuated to the open position to activate the reserve fuel system for operation. Two dual seal, high pressure gas charging valves and ports are provided, one on each side of the isolation valve. The valve filters prevent system contamination during testing and servicing.

### "E" Package

The "E" package (Figure 8-98) consists of a filter, one normally open pyrotechnic actuated valve, one normally closed pyrotechnic actuated valve, a normally closed two way solenoid valve, a pressure sensing switch, and a manual by-pass valve. The input filter prevents any contaminants from the "A" package from entering the "E" package. The two pyrotechnic actuated valves are activated (open to closed and closed to open) as required to maintain regulated system pressure, in the event of system regulator malfunction. The two way (open-close) solenoid valve is normally closed and functions upon crew command to maintain regulated system pressure in the event of a system regulator malfunction. The pressure switch senses regulated pressure from the system regulator. Upon sensing over pressure, the pressure switch intervenes and causes the normally open valve to actuate to the closed position, closing the inlet to the pressure regulator. The solenoid valve, when opened, allows pressurant flow through the package after the normally opened valve is actuated to the closed position. The manual by-pass (normally open) test valve is used to divert pressure to the solenoid valve, during system

# PROJECT GEMINI

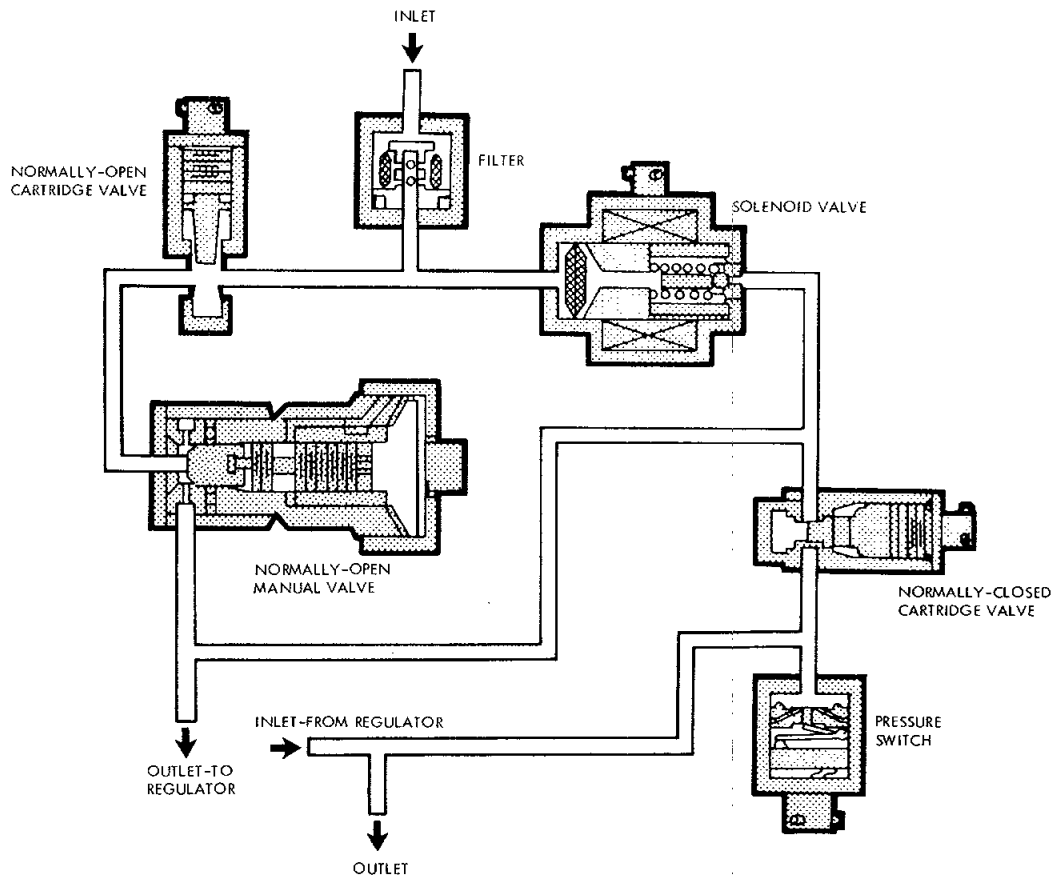
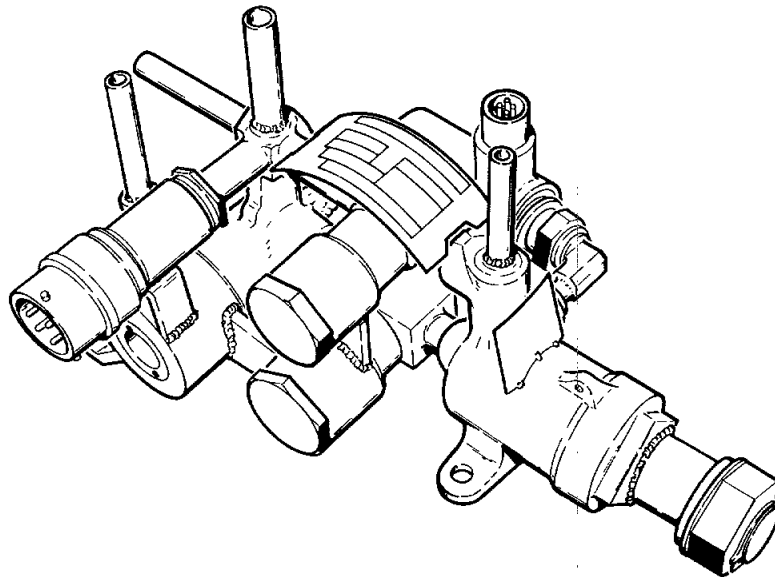
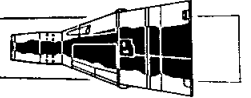

Figure 8-98 OAMS "E" Package



# PROJECT GEMINI



test.

In the normal mode of operation, gas flows through the normally open pyrotechnic valve to the system regulator. In the event system regulator over pressure malfunction, the pressure switch intervenes and causes the normally opened pyrotechnic valve to actuate to the closed position, diverting pressure to the normally closed solenoid valve. The solenoid valve is manually controlled (pulsed) by the crew to maintain regulated system pressure. In the event of system regulator (under pressure) malfunction, the normally closed pyrotechnic valve can be actuated to the open position. Simultaneously insured by the circuitry, the normally open valve is activated to the closed position. This prevents by-pass of the solenoid valve. In this mode, a regulator by-pass circuit is provided and pressure is regulated by the crew.

## Pressure Regulator

The pressure regulator (Figure 8-99) is a conventional, mechanical-pneumatic type. The regulator functions to reduce the source pressure to regulated system pressure. An inlet filter is provided to reduce any contaminants in the gas to an acceptable level. An outlet line is provided from the regulated pressure chamber to the pressure switch ("E" package) and activates the switch in the event of an over pressure malfunction.

## "B" Package

The "B" package (Figure 8-100) consists of filters, regulated pressure transducer, three check valves, two burst diaphragms, two relief valves, regulator out test port, fuel tank vent valve, inter-check valve test port, oxidizer tank vent valve, and two relief valve test ports. The inlet filter reduces any contaminants in

# PROJECT GEMINI

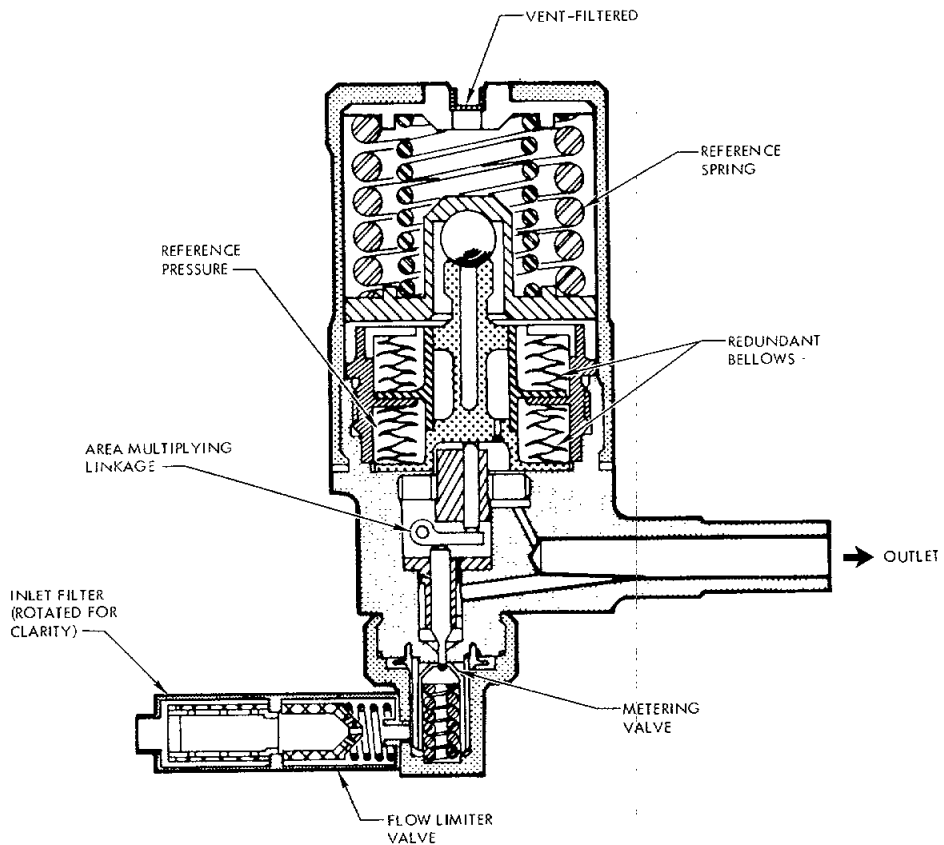
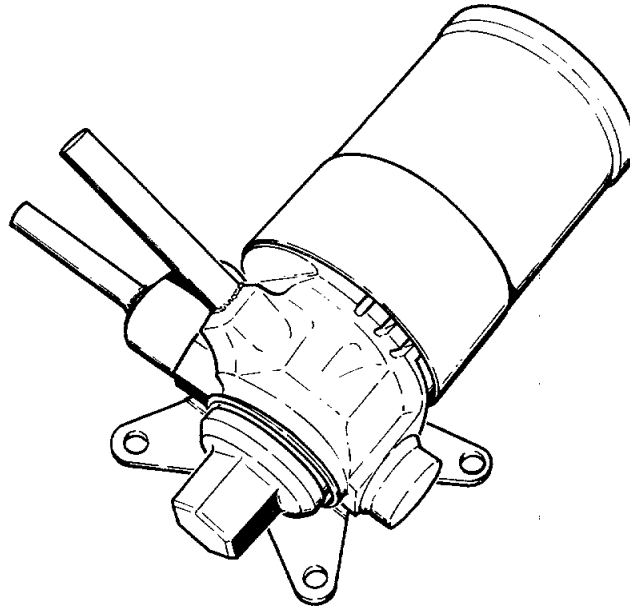
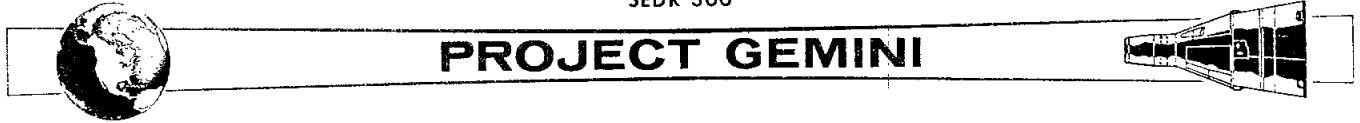

Figure 8-99 OAMS and RCS Pressure Regulator



# PROJECT GEMINI

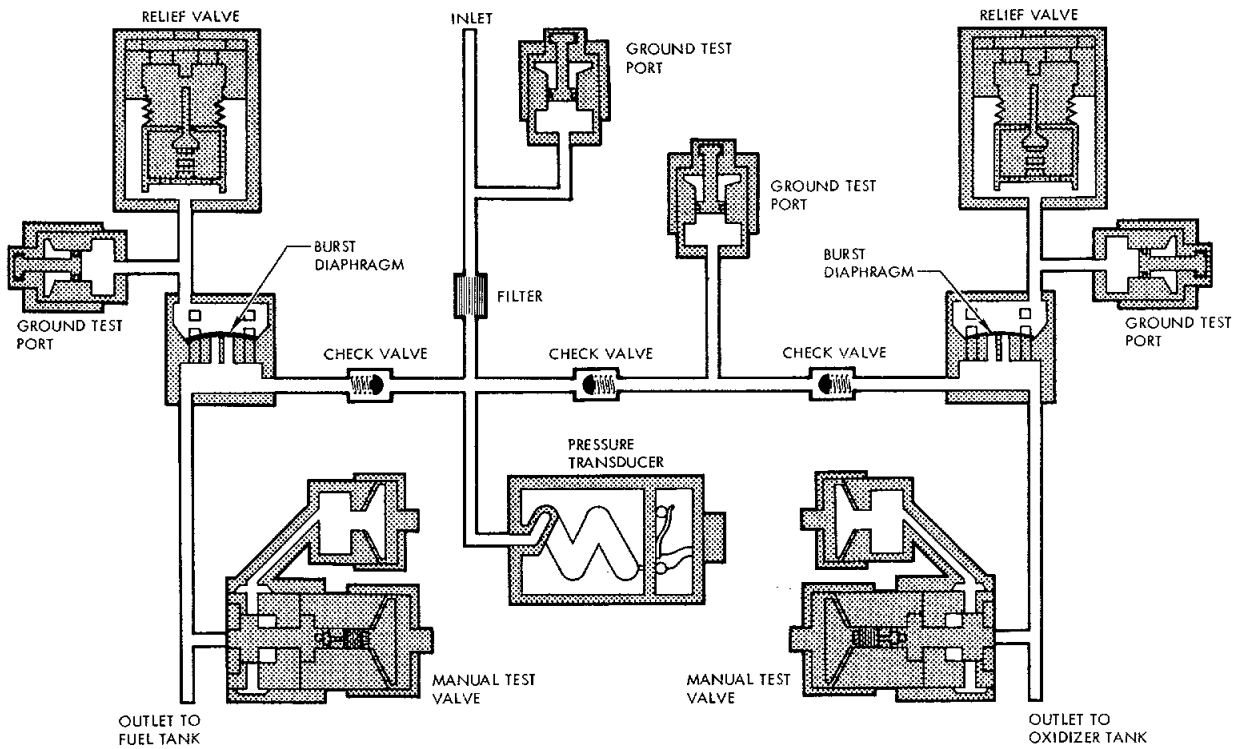
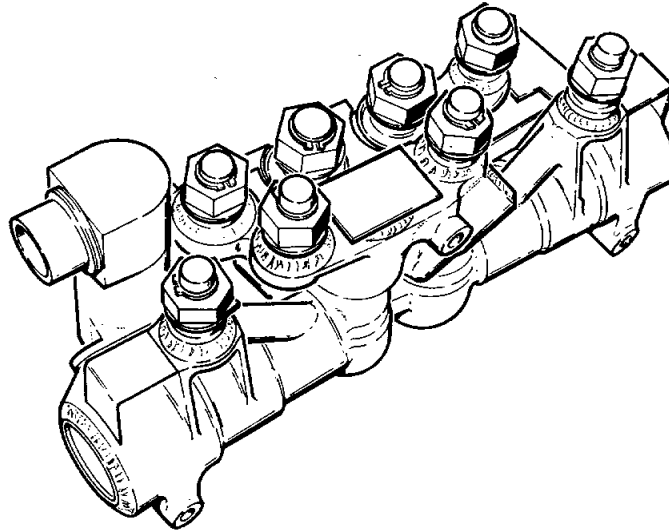
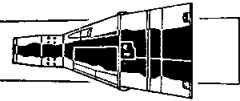

Figure 8-100 OAMS and RCS "B" Package



# PROJECT GEMINI



the gas to an acceptable level. Test valve inlet filters prevent any contaminants from entering the system. The regulated pressure transducer monitors the regulated pressure and transmits an electric signal to the cabin indicator and Instrumentation System, indicating the amount of regulated pressure on spacecraft 5 and 6. A single check valve prevents backflow of fuel vapors into the gas system. Two check valves are provided on the oxidizer side to prevent backflow of oxidizer into the system. The burst diaphragms are safety (over pressure) devices that rupture when regulated pressure reaches the design failure pressure, preventing excessive pressure from being imposed on the propellant bladders. The two relief valves are conventional, mechanical-pneumatic type with preset opening pressure. In the event of burst diaphragm rupture, the relief valve opens venting excess pressure overboard. The valve reseats to the closed position when a safe pressure level is reached, thereby, prevents venting the entire gas source. Manual valves and ports are provided to vent, purge and test the regulated system.

## Fuel Tank

The fuel storage tank (Figure 8-101) is welded, titanium spherical tank which contain an internal bladder and purge port. The tank dimension is 21.13 inches in diameter, and has a fluid volume capacity of 5355.0 cubic inches. The tank bladder is a triple layered Teflon, positive expulsion type. The helium pressurant is imposed on the exterior of the bladder to expel the fuel through the "D" package to the thrust chamber solenoid valves. Purge ports are provided to purge and vent the fuel tank. Temperature sensors are affixed to the input pressurant line, fuel tank exterior and output line to provide readings for the cabin indicator and Instrumentation System.

PROJECT GEMINI

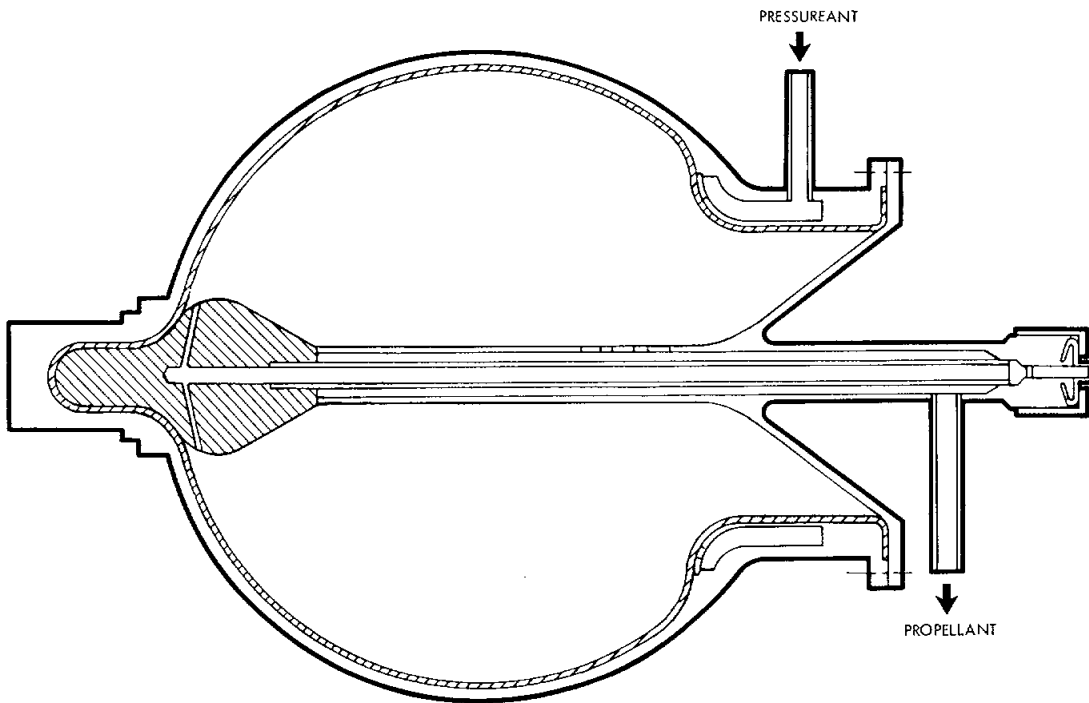
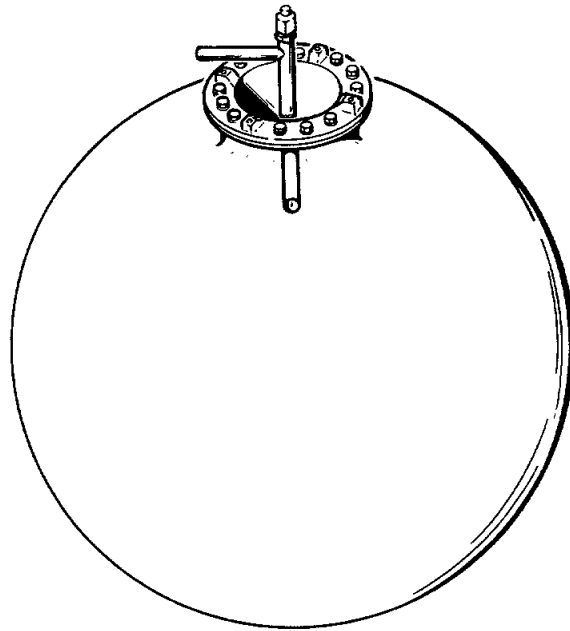
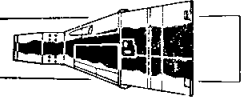

Figure 8-101 OAMS Propellant Tank

# PROJECT GEMINI

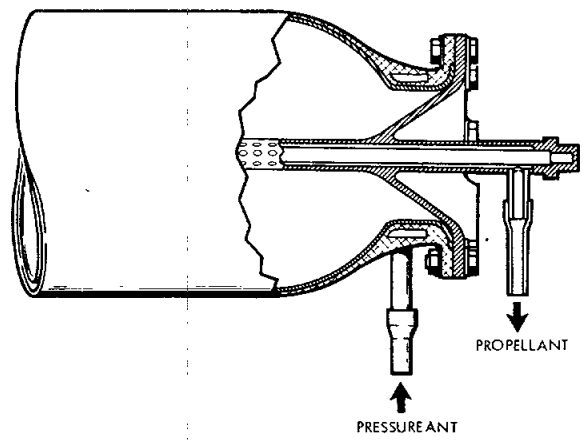
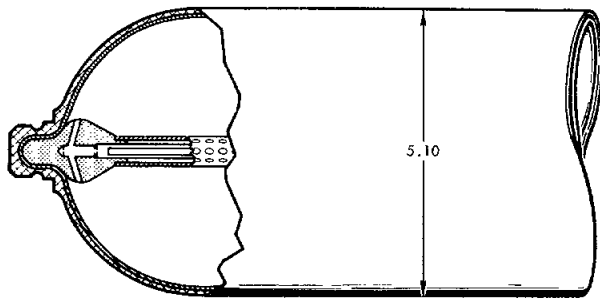
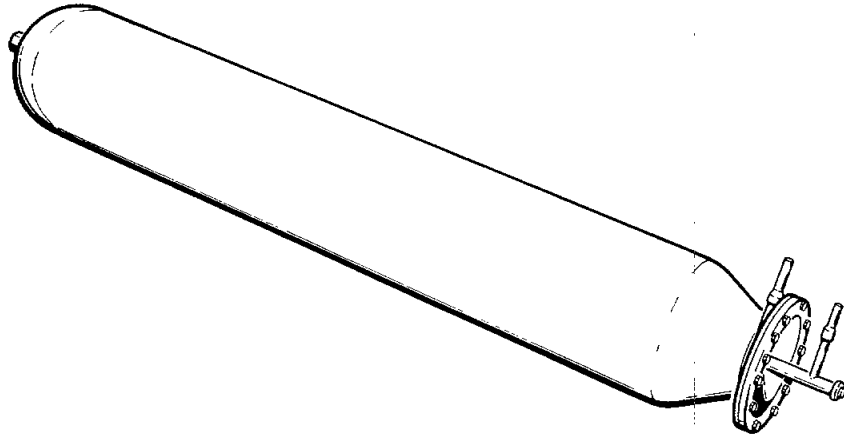
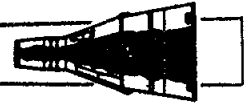

Figure 8-102 RCS Propellant Tanks



# PROJECT GEMINI



## Reserve Fuel Tank (Spacecraft 8 thru 12 only)

The reserve fuel tank (Figure 8-102) is a welded titanium cylindrical tank which contains an internal bladder and purge port. The tank is 5.10 inches outside diameter, 30.7 inches in length and has a fluid volume capacity of 546.0 cubic inches. The helium pressurant is imposed on the exterior of the bladder to expel fuel through the "D" package to the thrust chamber solenoid valves.

## Oxidizer Tank

The oxidizer tank (Figure 8-101) is a welded titanium spherical tank which contain a bladder and purge port. The tank is 21.12 inches in diameter, and has a fluid volume capacity of 5355.0 cubin inches. The tank bladder is double layered Teflon, positive expulsion type. The helium pressurant is imposed on the exterior of the bladder to expel the oxidizer through the "C" package to the thrust chamber solenoid valves. Purge ports are provided to purge and vent the oxidizer tanks. Temperature sensors are affixed to the input pressurant line, oxidizer tank exterior and output line to provide readings for the cabin indicator and Instrumentation System.

## "C" and "D" Packages

The "C" (oxidizer) and "D" (fuel) packages (Figure 8-103) are identical in function and are located downstream of the tanks of their respective system. Each package consists of a filter, isolation valve, propellant charging valve and test valve. The filter is located at the outlet port to prevent contaminants from entering the downstream system. The normally closed isolation valve is used to isolate propellants from the remainder of the system during the pre-launch waiting period. The pyrotechnic isolation valve is actuated to the open position

PROJECT GEMINI

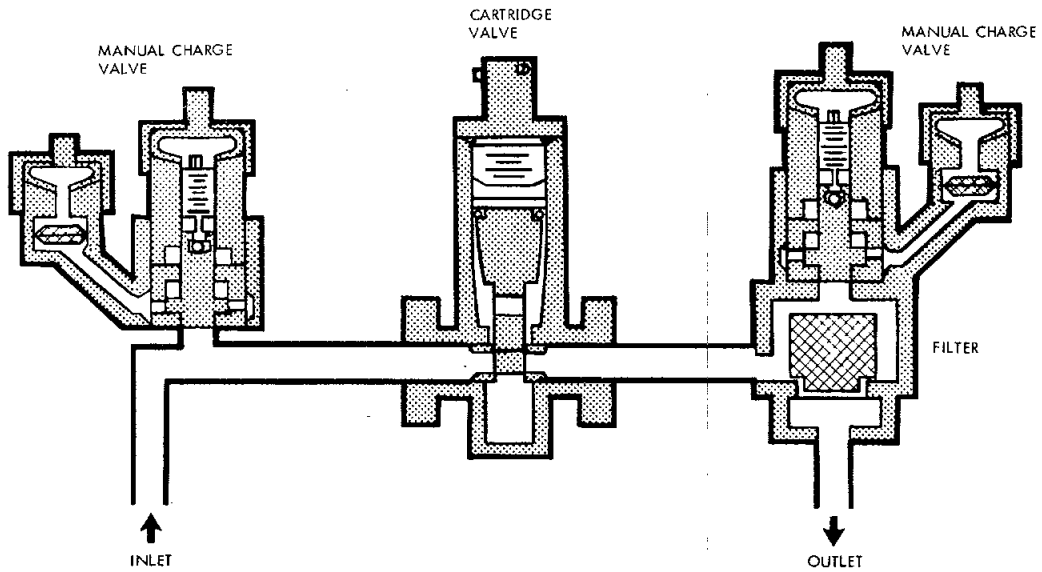
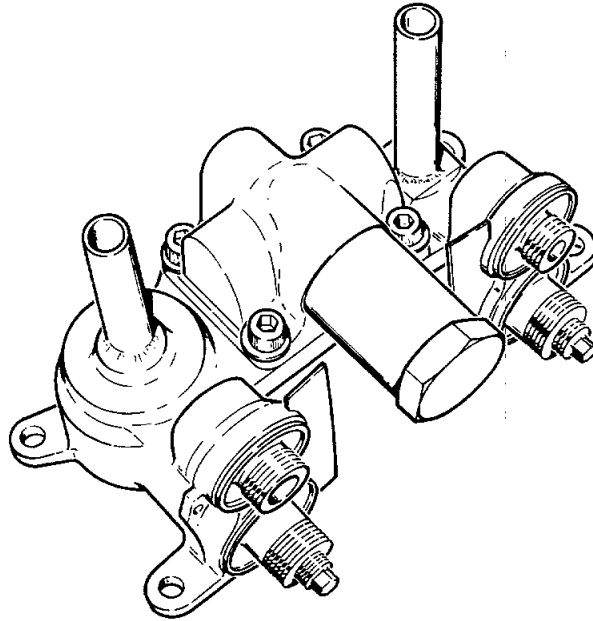
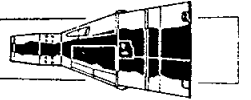
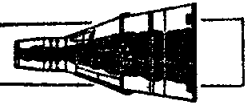

Figure 8-103 OAMS and RCS "C" and "D" Package



# PROJECT GEMINI



for system operation. The propellant charging valve is located upstream of the isolation valve and is used for servicing and venting the system. The test valve is located downstream of the isolation valve and is used to test the downstream system.

## Propellant Supply Shutoff Valves

Propellant supply shutoff valves (Figure 8-104) are provided for both the oxidizer and fuel system and are located downstream of the "C" and "D" packages. The motor driven shutoff valves are electrically operated and manually controlled. The propellant valves serve as safeguards in the event of TCA leakage. The valves are normally in the open position, and are closed at the option of the crew to prevent loss of propellants. The valve is thereafter reopened only when it is necessary to actuate the TCA's for the purpose of the spacecraft control.

## Thrust Chamber Assembly (TCA) Group

Each TCA (Figure 8-105, 8-106 and 8-107) consists of two propellant solenoid valves, an electric heater, injection system, calibrated orifices, combustion chamber and an expansion nozzle. The propellant solenoid valves are quick acting, normally closed valves, which open simultaneously upon application of an electric signal. This action permits fuel and oxidizer flow to the injector system. The injectors utilize precise jets to impinge fuel and oxidizer streams on one another for controlled mixing and combustion. The calibrated orifices are fixed devices used to control propellant flow. Hypergolic ignition occurs in the combustion chamber. The combustion chamber and expansion nozzle are lined with ablative materials and insulation to absorb and dissipate heat, and control wall temperature.

PROJECT GEMINI

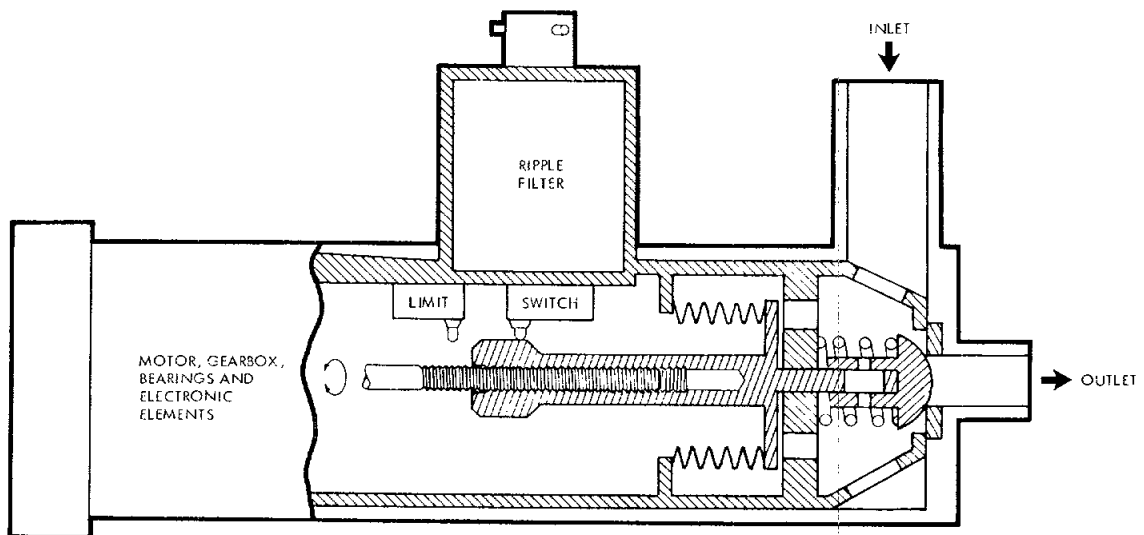
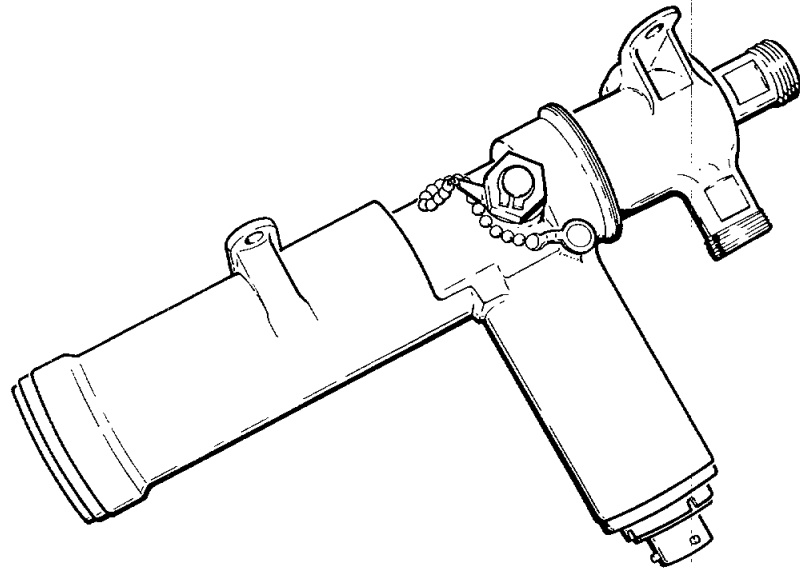
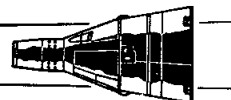

Figure 8-104 OAMS and RCS Propellant Shutoff Valve

# PROJECT GEMINI



**NOTE**

LONG LIFE TCA'S ARE USED ON MISSIONS REQUIRING EXTENSIVE MANEUVERING OR EVA (EXTRA VEHICULAR ACTIVITY).

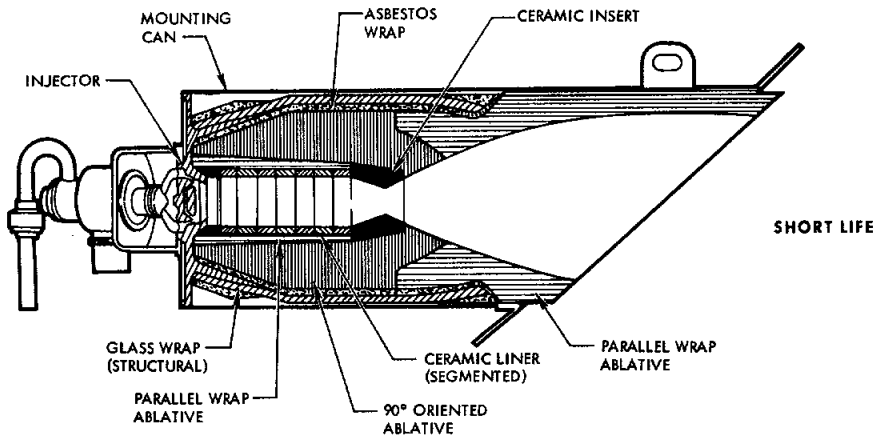
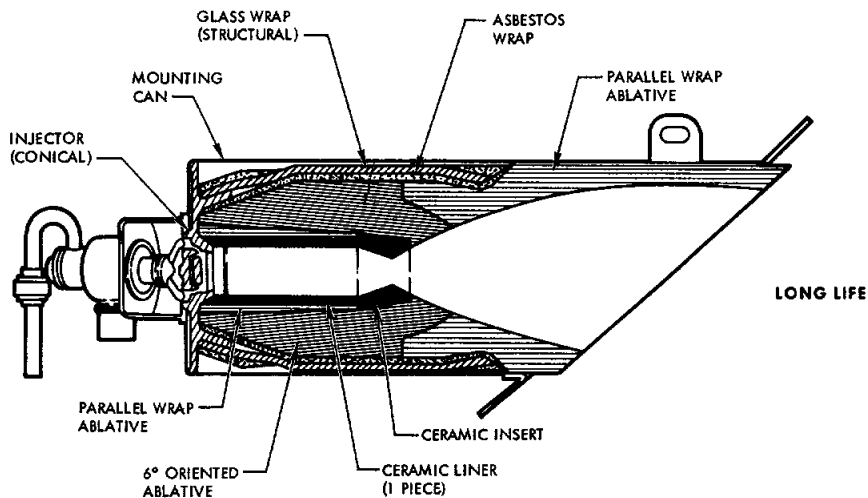
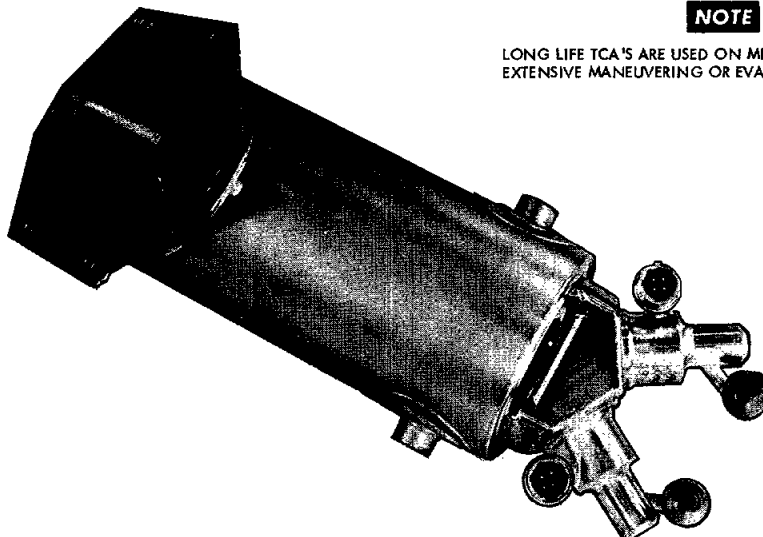
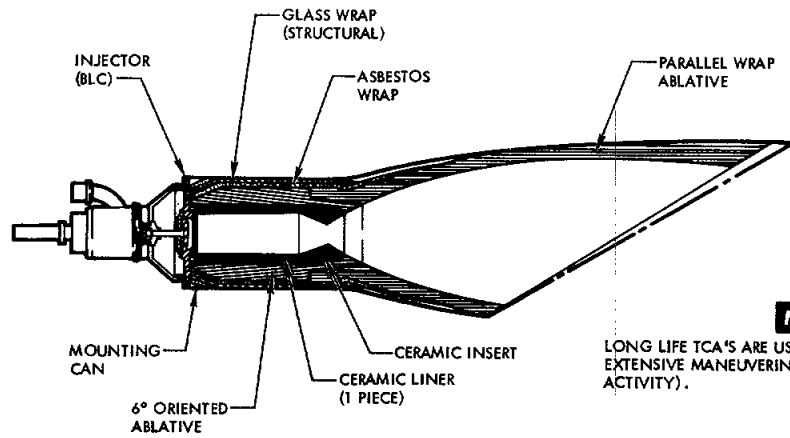
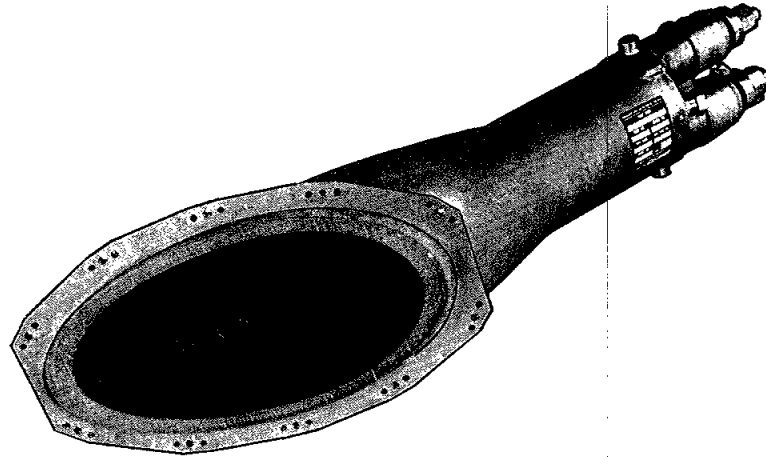
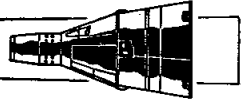

Figure 8-105 OAMS 25 Lb. TCA



# PROJECT GEMINI



LONG LIFE

**NOTE**

LONG LIFE TCA'S ARE USED ON MISSIONS REQUIRING EXTENSIVE MANEUVERING OR EVA (EXTRA VEHICULAR ACTIVITY).

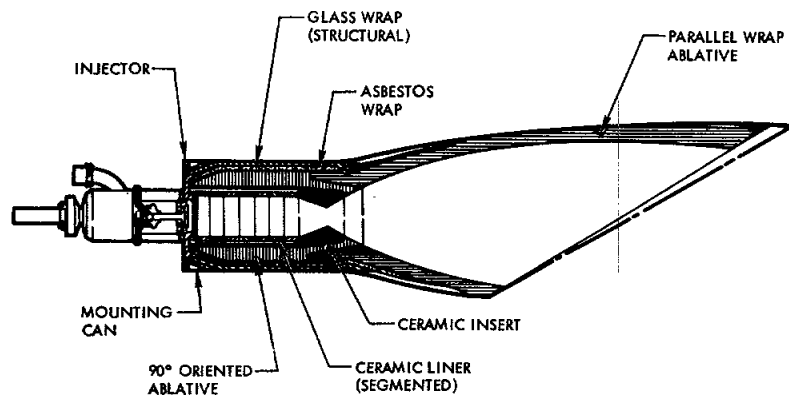

SHORT LIFE

Figure 8-106 OAMS 85 Lb. TCA

# PROJECT GEMINI

**NOTE**

LONG LIFE TCA'S ARE USED ON MISSIONS REQUIRING EXTENSIVE MANEUVERING OR EVA (EXTRA VEHICULAR ACTIVITY).

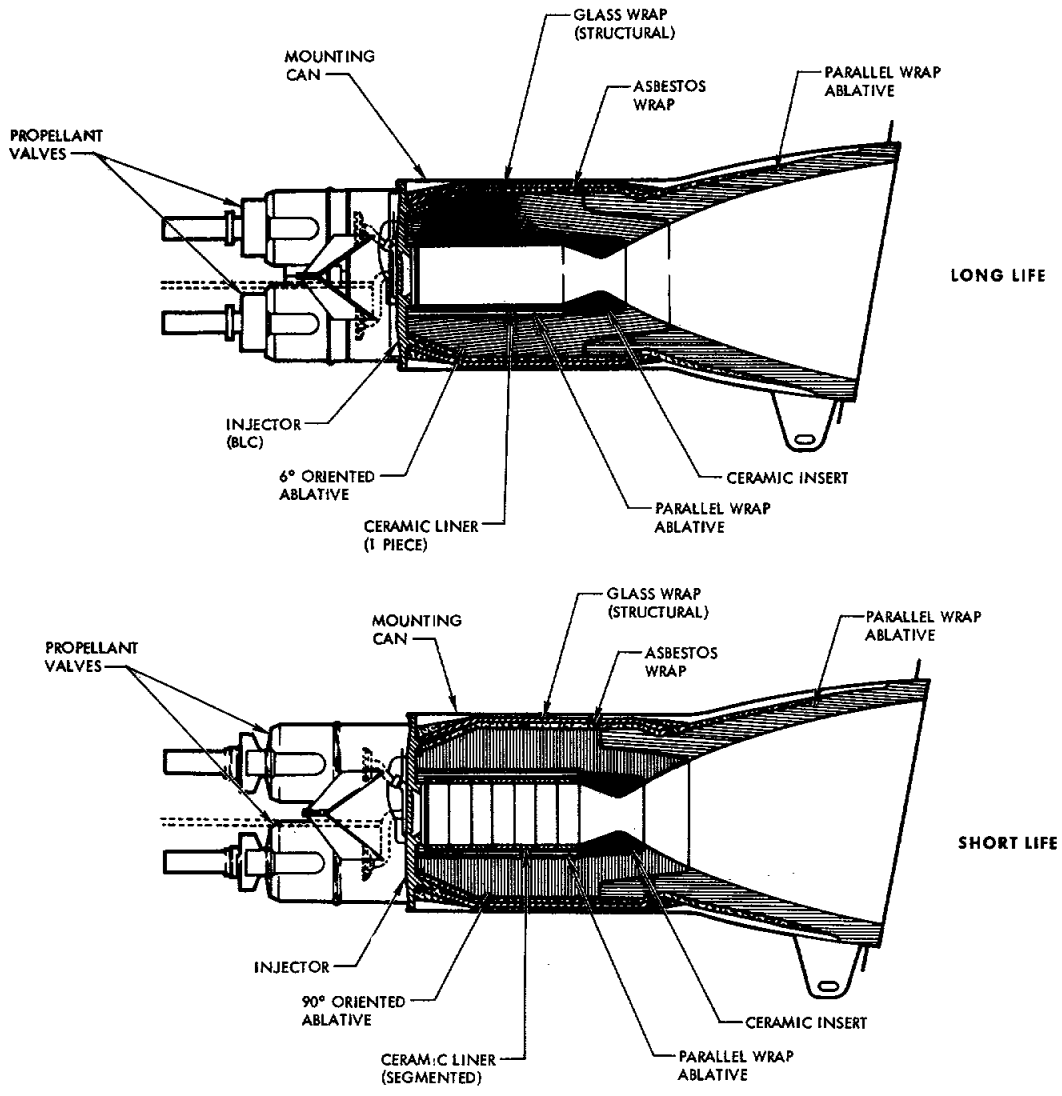
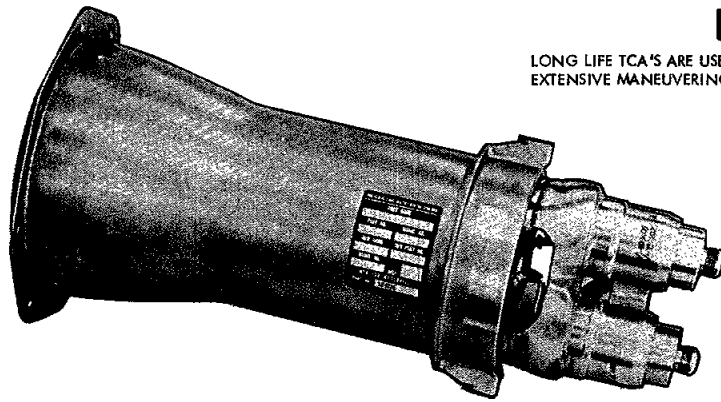

Figure 8-107 OAMS 100 Lb. TCA



# PROJECT GEMINI



TCA's are installed within the adapter with the nozzle exits terminating flush with the outer moldline and located at various points about the adapter section suitable for the attitude and maneuvering control required. Electric heaters are installed on the TCA oxidizer valves to prevent the oxidizer from freezing.

## Tubing Cutter/Sealer

The tubing cutter/sealer is a pyrotechnic actuated device and serves to positively seal and cut the propellant feed lines. Two such devices are provided for each feed line and are located downstream of the propellant supply on/off valve, one each in the retrograde and equipment section of the adapter. Prior to retrofire, the equipment section is jettisoned. The devices are actuated to permit separation of the feed lines crossing the parting line, and to contain the propellants upon separation.

## RE-ENTRY CONTROL SYSTEM

### SYSTEM DESCRIPTION

The Re-entry Control System (RCS) (Figure 8-108) is a fixed thrust, cold gas pressurized, storable liquid, hypergolic bi-propellant, self contained propulsion system used to provide attitude control of the spacecraft during re-entry.

### NOTE

The RCS consists of two identical but entirely separate and independent systems. The systems may be operated individually or simultaneously. One system will be described, all data is applicable to either system.

The RCS is capable of operating outside of the earth's atmosphere.

# PROJECT GEMINI

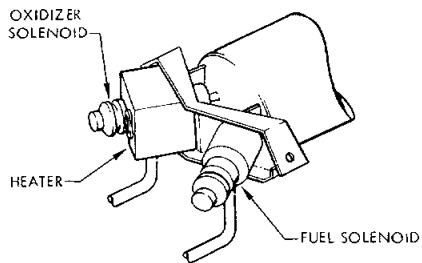
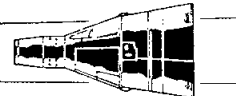

DETAIL A

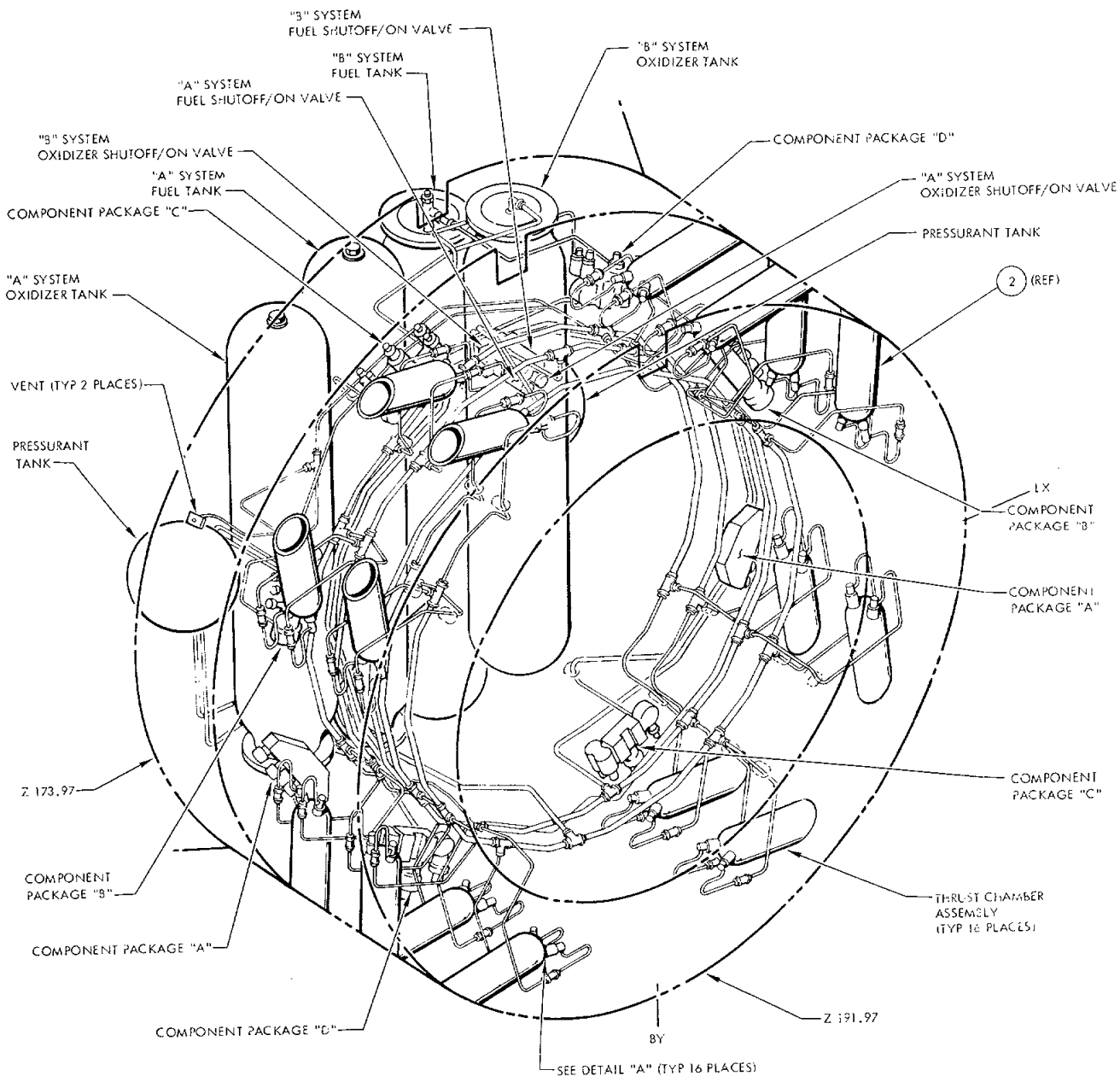
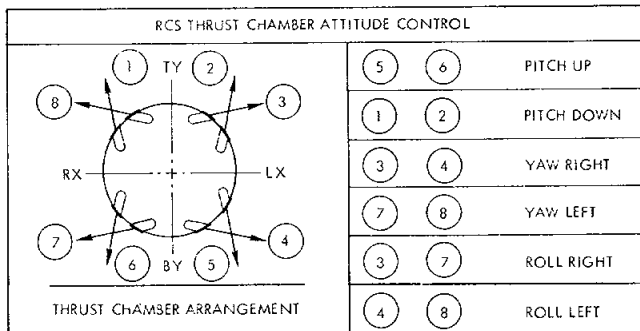

Figure 8-108 Re-entry Control "A" and "B" Systems



# PROJECT GEMINI



Attitude control (roll, pitch and yaw) is obtained by firing the TCA's in groups. The TCA's are mounted at various points about the RCS section of the spacecraft consistent with the modes of rotational control required. The entire RCS, (tanks and control packages), with the exception of instrumentation, is located in the RCS section of the spacecraft. Each package consists of several functioning components and filters. The delivery of pressurants and propellants is accomplished by a uniquely brazed tubing manifold system. The RCS is divided into three groups; pressurant group, the oxidizer/fuel (propellant) group and the Thrust Chamber Assembly (TCA) group.

## Pressurant Group

The pressurant group (Figure 8-109) consists of a pressurant tank, "A" package, pressure regulator and "B" package. Valves and test ports are provided at accessible points to permit servicing, venting, purging and testing. Filters are provided throughout the system to prevent system contamination. The pressurant is stored and isolated from the remainder of the system during pre-launch periods by a normally closed pyrotechnic actuated valve, located in the "A" package.

## Fuel/Oxidizer Group

The fuel/oxidizer (propellant) group (Figure 8-109) consists of expulsion bladder storage tanks, "C" (oxidizer) and "D" (fuel) packages. Valves, ports and test ports are provided at accessible areas to permit servicing, venting, purging and testing. Filters are provided throughout the system to prevent contamination. The propellants are isolated in the storage tanks from the remainder of the system by normally closed pyrotechnic actuated valves in the "C" and "D" packages. Heaters are provided on the "C" package to maintain the oxidizer at an operating temperature

# PROJECT GEMINI

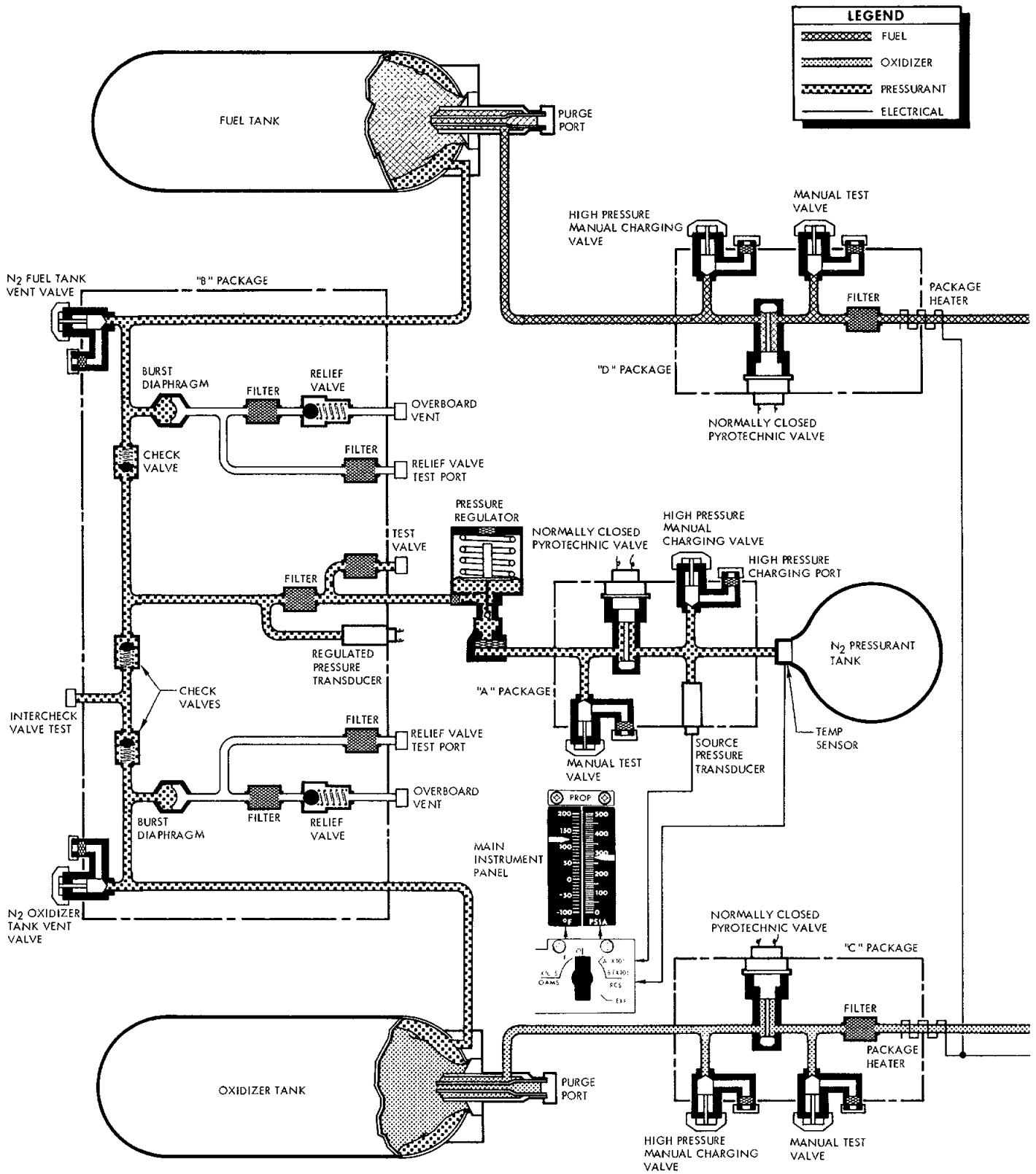
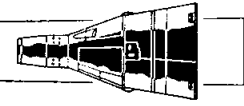

Figure 8-109 RCS (Single System) (Sheet 1 of 2)

# PROJECT GEMINI

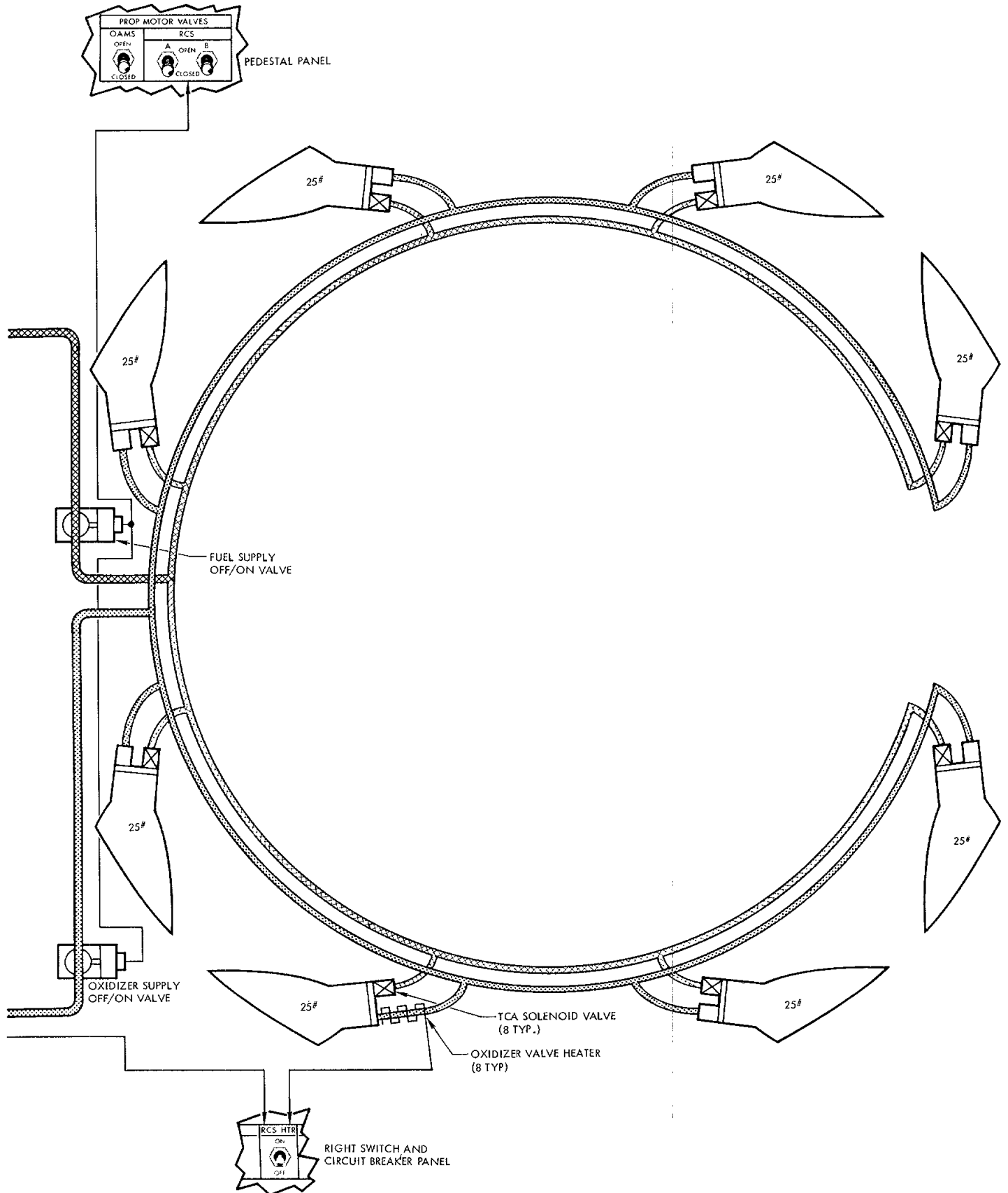
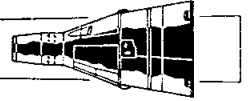

Figure 8-109 RCS (Single System ) (Sheet 2 of 2)

8-373



# PROJECT GEMINI



The propellants used are:

Oxidizer - Nitrogen Tetroxide ( $N_2O_4$ ) conforming to  
Specification MIL - P - 26539A

Fuel - Monomethyl Hydrazine ( $N_2H_3CH_3$ ) conforming  
to specification MIL - P - 27404

## Thrust Chamber Assembly (TCA) Group

The TCA group (Figure 8-108) consists of eight twenty-five pound TCA's used for attitude (roll, pitch and yaw) control of the re-entry module. Each TCA is equipped with thrust chamber and electric controlled solenoid valves. Heaters are provided on the oxidizer solenoid valves to maintain the oxidizer at an operating temperature.

## SYSTEM OPERATION

### Pressurant Group

(Figure 8-105) High pressure nitrogen ( $N_2$ ) (pressurant), is stored at 3000 psi in the pressurant tank. The tank is serviced through the "A" package high pressure gas charging port. Pressure from the pressurant tank is isolated from the remainder of the system, until ready for operation, by a normally closed pyrotechnic actuated valve located in the "A" package. Stored nitrogen pressure is monitored and transmitted to the cabin indicator and Instrumentation System by the source pressure transducer located in the "A" package. Upon command, the "A" package pyrotechnic actuated valve is opened (simultaneously with propellant "C" and "D" package pyrotechnic actuated valves) and nitrogen flows to the pressure regulator and "B" package. The "B" package provides a division of flow to the



# PROJECT GEMINI



propellant tanks. The regulated pressure is sensed by the regulated pressure transducer ("B package) and provides a signal to the Instrumentation System, indicating pressure downstream of the regulator. The check valves prevent back-flow of propellant vapors into the pressurant system. The "B" package also provides a safety feature to prevent over pressure of the fuel and oxidizer tank bladders. Should the system be over pressurized downstream of the regulator the over pressure would first rupture the burst diaphragms, then be vented overboard through the relief valves.

## Fuel/Oxidizer Group

Fuel and oxidizer (propellants) are stored in their respective tanks, and are serviced through the high pressure charging ports in the "C" and "D" packages. The propellants are isolated from the remainder of the system, until ready for operation, by the normally closed pyrotechnic valves in the "C" and "D" packages. Upon command the "A" (pressurant), "C" (oxidizer) and "D" (fuel) package pyrotechnic actuated valves are opened and propellants are distributed through their separate tubing manifold system to the thrust chamber inlet solenoid valves.

Two motor driven shutoff valves are located in the propellant feed lines, upstream of the TCA's. In the event of fuel or oxidizer leakage through the TCA solenoid valves, the motor operated valves can be closed by the crew to prevent loss of propellants. The valves can again be actuated open by the crew, when required, to deliver propellants to the TCA solenoids. Heaters are connected to the output lines of the "C" and "D" packages and are activated by the RCS HTR switch (Figure 8-109).

## Thrust Chamber Assembly (TCA) Group



# PROJECT GEMINI



Upon command from the automatic or manual controls, signals are transmitted through the Attitude Control Maneuvers Electronics (ACME) to selected TCA's to open simultaneously, the normally closed, quick acting fuel and oxidizer solenoid valves mounted on each TCA. In response to the signals, propellants are directed through small injector jets into the combustion chamber. The controlled fuel and oxidizer impinge on one another, where they ignite hypergolically to burn and create thrust. Heaters are connected to each TCA oxidizer solenoid valve to prevent freeze-up and are activated by the RCS HTR switch (Figure 8-109).

## SYSTEM UNITS

### Pressurant Storage Tank

The nitrogen ( $N_2$ ) pressurant is stored in a welded, titanium spherical tank. The tank is 7.25 inches outside diameter and has an internal volume of 185.0 cubic inches. Nitrogen gas is stored at 3000 psi and held therein by the "A" package pyrotechnic valve. This nitrogen, under pressure, is used to expel the fuel and oxidizer from their respective tanks. Temperature sensors are affixed to the pressurant outlet line to provide readings for the cabin instrument and telemetry.

### "A" Package

The "A" package (Figure 8-97) consists of a source pressure transducer, isolation valve, filters and two high pressure gas charging valves. The source pressure transducer monitors the stored pressure and transmits an electric signal to the cabin indicator indicating the pressure of the stored gas. The normally closed isolation valve is used to isolate the pressure from the remainder of the system.



# PROJECT GEMINI



The valve is pyrotechnically actuated to the open position to activate the system for operation. Two dual seal, high pressure gas charging valves and ports are provided, one on each side of the isolation valve. The upstream valve is used for servicing, venting and purging the pressurant tank, while the downstream valve is used to test downstream components. Filters are provided to prevent contaminants from entering the system.

## Pressure Regulator

The pressure regulator (Figure 8-99) is a conventional, mechanical-pneumatic type. The regulator functions to reduce the source pressure to regulated system pressure. An inlet filter is provided to reduce any contaminants in the gas to an acceptable level.

## "B" Package

The "B" package (Figure 8-100) consists of filters, regulated pressure transducer, three check valves, two burst diaphragms, two relief valves, regulator output test port, fuel tank vent valve, oxidizer tank vent valve, inter-check valve test port and two relief valve test ports. The inlet filter reduces any contaminants in the gas to an acceptable level. Valve inlet filters prevent contaminants from entering the system. The pressure transducer monitors the regulated pressure and transmits an electrical signal to the spacecraft Instrumentation System. A single check valve prevents backflow of fuel vapors into the gas system. Two check valves are provided on the oxidizer side to prevent backflow of oxidizer vapor into the gas system. The burst diaphragms are safety devices that rupture when the regulated pressure reaches the design failure pressure, preventing excessive pressure from being imposed on the propellant bladders.



# PROJECT GEMINI



The two relief valves are conventional mechanical-pneumatic type with preset opening pressure. In the event of burst diaphragm rupture, the relief valve opens, venting excess pressure overboard. The valve reseats to the closed position when a safe level is reached, preventing the entire gas source from being vented overboard. Manual valves and ports are provided to vent, purge and test the regulated system.

## Fuel Tank

The fuel tank (Figure 8-102) is a welded, titanium cylindrical tank which contains an internal bladder and purge port. The tank is 5.10 inches outside diameter, 30.7 inches in length and has a fluid volume capacity of 546.0 cubic inches. The nitrogen pressurant is imposed on the exterior of the bladder to expel fuel through the "D" package to the TCA solenoid valves. The purge port is provided to purge and vent the fuel tank bladder. Temperature sensors are affixed to the nitrogen input line and fuel output line to transmit signals to Instrumentation System.

## Oxidizer Tank

The oxidizer tank (Figure 8-102) is a welded, titanium cylindrical tank which contains a bladder and purge port. The tank is 5.10 inches outside diameter, 25.2 inches in length and has a fluid volume capacity of 439.0 cubic inches. The bladder is a double layered Teflon, positive expulsion type. The nitrogen pressurant is imposed on the exterior of the bladder to expel the oxidizer through the "C" package to the TCA solenoid valve. The purge port is provided for purging and venting the oxidizer tank bladder. Temperature sensors are affixed to the nitrogen input line and oxidizer output line to transmit signals to Instrumentation System.



# PROJECT GEMINI



## "C" and "D" Packages

The "C" and "D" packages (Figure 8-103) are identical in function and are located downstream of the tanks of their respective system. Each package consists of filters, an isolation valve, propellant charging valve and test valve. The filter, located at outlet port, reduces contaminants to an acceptable level. The valve and port filters prevent contaminants from entering the system. The normally closed isolation valve is used to isolate propellants from the remainder of the system during the pre-launch period. The isolation valve is pyrotechnic actuated to the open position for system operation. The propellant charging valve is located upstream of the isolation valve and is used for servicing and venting the system. The test valve is located downstream of the isolation valve and is used to test the downstream system.

## Propellant Supply Shutoff Valves

Propellant supply shutoff valves (Figure 8-104) are provided for both the oxidizer and fuel system, and are located downstream of the "C" and "D" packages in the system. The motor driven shutoff valves are electrically operated, and manually controlled. The valves are normally in the open position, and are closed at the option of the crew to prevent loss of propellants. The valves are reopened only when the TCA's are needed for spacecraft control.

## Thrust Chamber Assembly (TCA) Group

Each TCA (Figure 8-110) consists of two propellant valves, injection system, calibrated orifices, combustion chamber and expansion nozzle. The fuel and oxidizer solenoid valves are quick acting, normally closed valves, which open simultaneously upon application of an electric signal. The action permits fuel and

PROJECT GEMINI

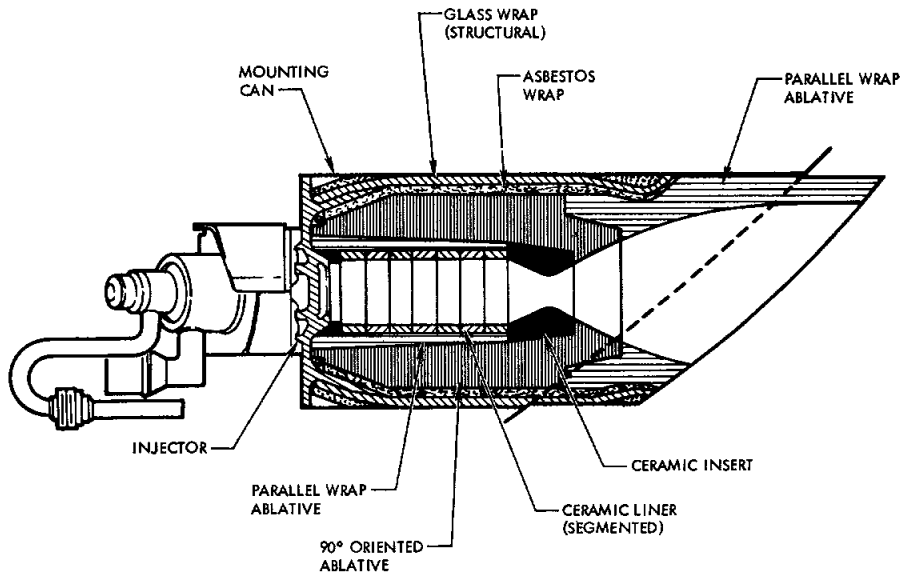
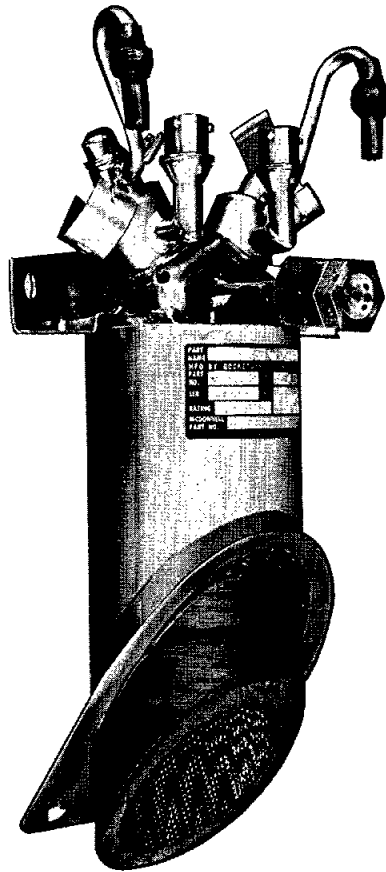

Figure 8-110 RCS 25 Lb. TCA



# PROJECT GEMINI



oxidizer flow into the injector system. The injectors use precise jets to impinge fuel and oxidizer streams on one another for controlled mixing and combustion. The calibrated orifices are fixed devices used to control propellant flow. Hypergolic ignition occurs in the combustion chamber. The combustion chamber and expansion nozzle is lined with ablative materials and insulation to absorb and dissipate heat and control external wall temperature. TCA's are installed within the RCS section mold line, with the nozzles terminating flush with the outer mold line. TCA's are located at fixed points in the RCS section in a location suitable for attitude control. Electric heaters, located on the oxidizer valve, are used to prevent the oxidizer from freezing.